

STROKE BALL SPLINE

The NB stroke ball spline SPLFS type is a high accuracy linear motion bearing with a limited stroke, to which both radial load and torque can be applied at the same time. It operates with extremely small dynamic friction.

STRUCTURE AND ADVANTAGES

The NB stroke ball spline consists of a nut and a shaft both with raceway grooves. Since the retainer in the nut is equipped with a ball pocket, the steel balls, (rolling elements) do not contact each other, which allows for a smooth linear motion.

In a linear motion, however, the retainer moves a half of the travel distance. Therefore, the linear travel stroke is limited up to twice as long as the distance that the retainer can move in the nut. For normal operation, it is recommended to consider 80% of the maximum stroke shown in the dimension list as an actual travel distance.

Extremely Small Dynamic Friction and Low Noise:

The rolling elements are separated by the ball pockets so that they do not contact each other. The stroke length is limited, but extremely small dynamic friction and low noise are realized because the rolling elements do not circulate.

Compact-Size:

With the nut about 20% smaller than existing ball splines, it contributes to space saving.

All Stainless Steel:

Since all the components are made of stainless steel, this stroke ball spline has an excellent corrosion resistance and heat resistance (operating temperature: -20 to +140°C). It is ideal for clean-room or vacuum applications.

Lubrication:

A lubricant groove and two lubrication holes are provided on the outer surface of the nut, which allow for an easy designing of lubricant replenishment.

Figure B-25 Structure of SPLFS Type

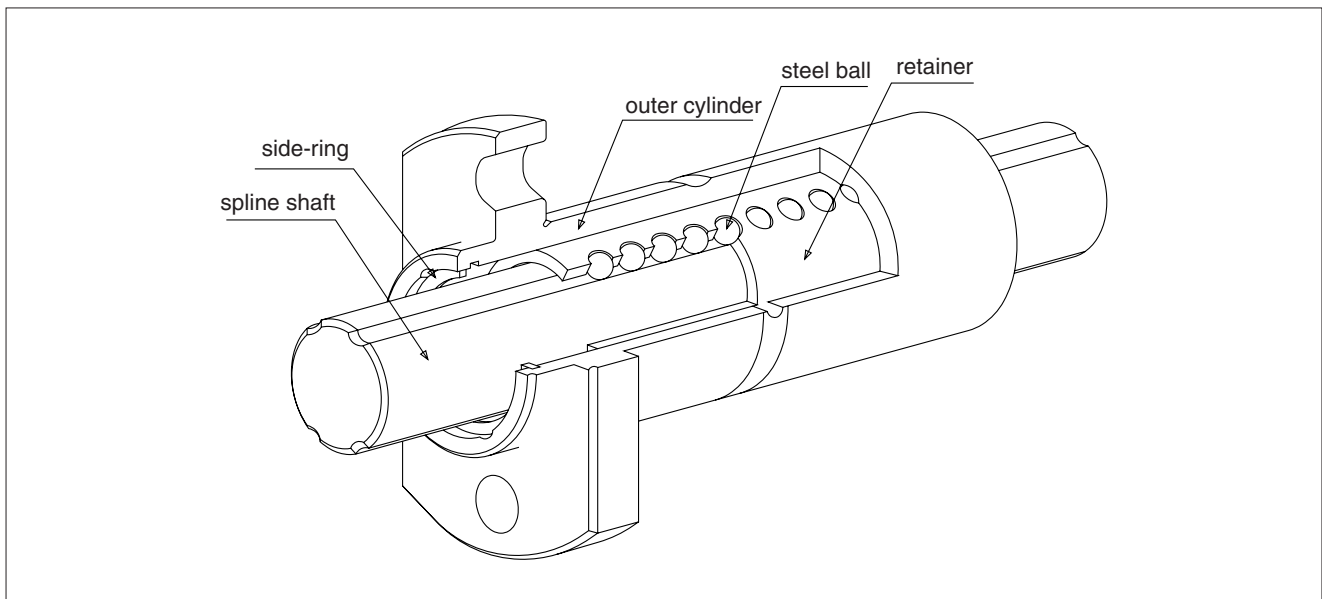

ACCURACY

The accuracy of the NB stroke ball spline is measured as shown in the figure below.

Figure B-26 Accuracy

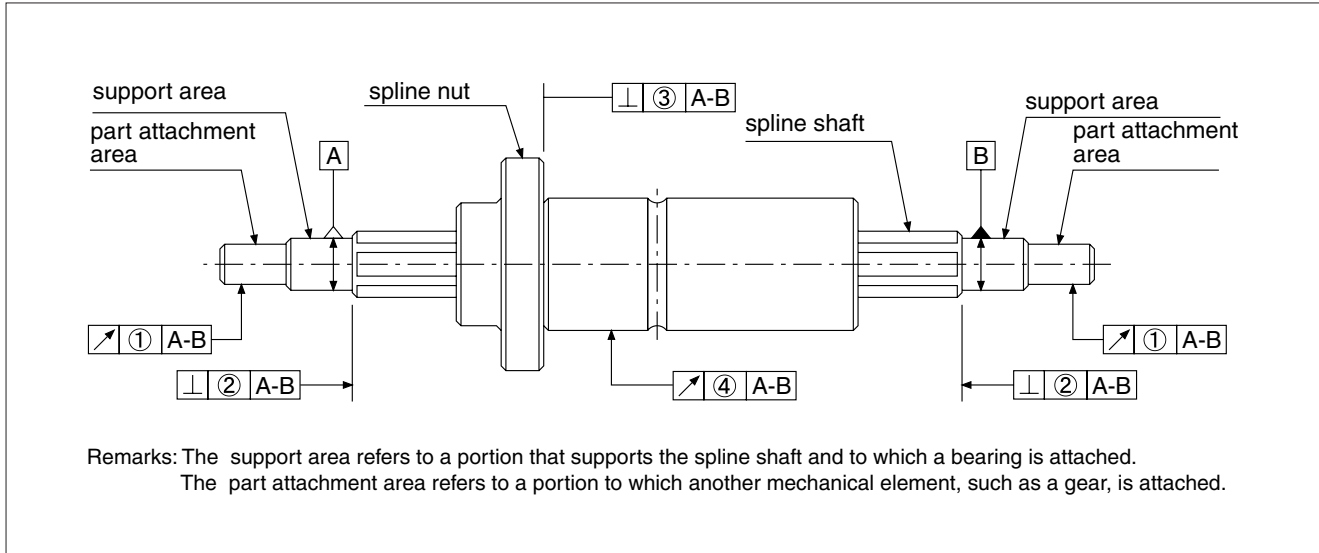

Spline Shaft/Groove Distortion Tolerance (Maximum)

Groove distortion is measured at a given 100 mm out of the effective length of the spline portion. When the travel distance is less or more than 100 mm, increase or decrease the value shown in Table B-22 in proportion to the travel distance.

Table B-22 Spline Shaft/Groove Distortion Tolerance (Maximum)

tolerance (μm)
13

Table B-23 Tolerance of Parts Relative to Spline Support Area (Max.)

unit/ μm

part number	① radial run out of part attachment area	② perpendicularity of the end of the spline shaft section	③ perpendicularity of the flange
SPLFS 6	14	9	11
SPLFS 8	14	9	11
SPLFS10	17	9	13
SPLFS13	19	11	13
SPLFS16	19	11	13

Table B-24 ④Radial Run-Out of Outer Surface of Spline Nut Relative to Spline Support Area (Max.)

unit/ μm

spline shaft total length		part number		
greater than	or less	SPLFS6,8	SPLFS10	SPLFS13,16
	200	46	36	34
200	315	89	54	45
315	400	126*	68	53
400	500	163*	82	62
500	630	—	102	75
630	800	—	—	92
800	1,000	—	—	115
1,000	1,250	—	—	153
1,250	1,500	—	—	195

* maximum fabrication length of SPLFS6: 400 mm

PRE-LOAD AND CLEARANCE IN ROTATIONAL DIRECTION

Both the clearance and pre-load are expressed in terms of clearance in the rotational direction. For the SPLFS type, only the standard value shown below is available. Contact us if you need a clearance other than shown in Table B-25.

Table B-25 Pre-Load and Clearance in Rotational Direction unit/ μm

part number	standard
SPLFS 6	0~-4
SPLFS 8	0~-4
SPLFS10	0~-4
SPLFS13	0~-4
SPLFS16	0~-4

COMPARISON OF DYNAMIC FRICTION RESISTANCE

Figure B-27 Comparison Data of dynamic Friction Resistance

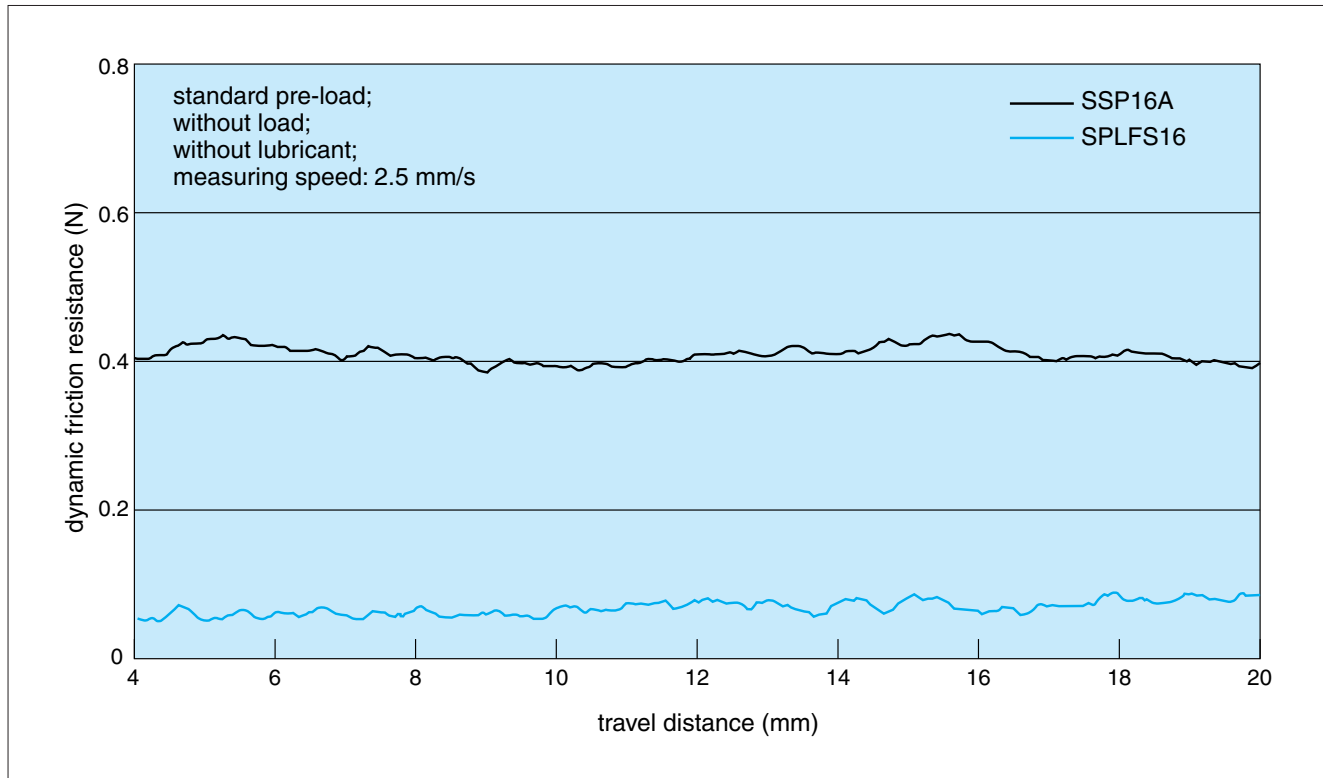

NOTES ON USE

Dust Control:

Since the stroke ball splines are designed and manufactured for operating with an extremely small dynamic friction resistance, any seal that increases the dynamic friction resistance is not equipped as a standard feature. If you use this type of spline under unfavorable conditions, contact us and a special seal will be available. For use under extremely unfavorable conditions, the stroke ball spline should be protected using bellows and protective covers.

Retainer Misalignment:

If the stroke ball spline is used at a high speed or with a vertical shaft, or under an asymmetric load or oscillation, a retainer misalignment may occur. For general operation, it is recommended to consider 80% of the maximum stroke length shown in the dimension list as a travel distance.

In order to prevent the retainer misalignment, it is also recommended to conduct a full-stroke moving operation times during use so that the retainer will be relocated to the center.

SPLFS TYPE

- Two Side Cut Flange Type -

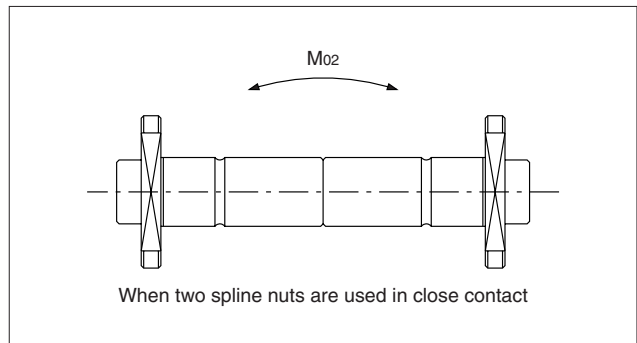
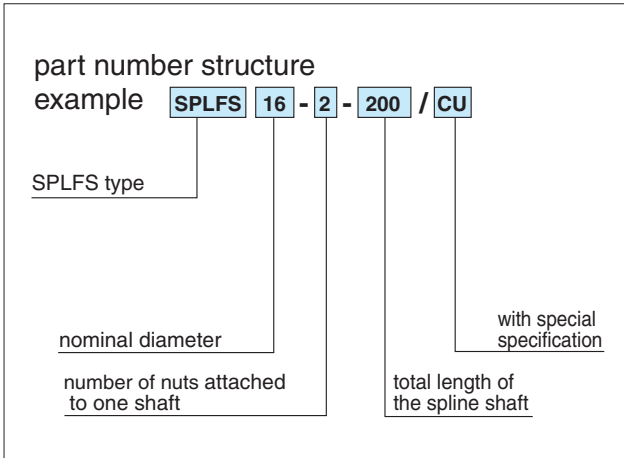
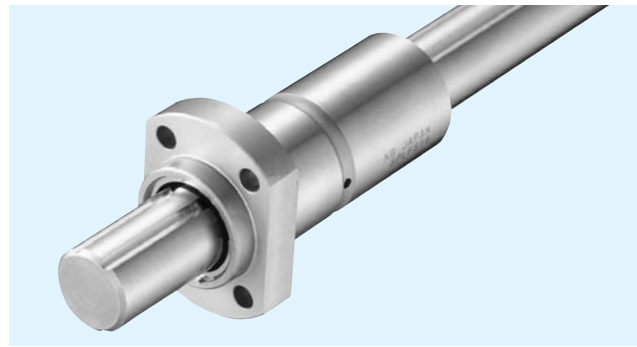

part number	maximum stroke mm	major dimensions												
		D		D ₁	L		E	D _f	H	B	P.C.D.	A	F	N ₁ -S
		mm	tolerance μm		mm	mm								
SPLFS 6	22	11	0	10	40	0 -0.2	3.3	23	4	14	17	-	-	2-3.4
SPLFS 8	20	13	-8	12.5	40		3.3	25.5	4	16	19.5	-	-	2-3.4
SPLFS10	28	16		15.5	50		3.3	28.5	5	20	-	18	13	4-3.4
SPLFS13	24	20	0	19.5	50		4.8	36	5	25	-	22	17	4-3.4
SPLFS16	26	24	-9	23.5	60		4.8	40	7	29	-	25	19	4-4.5

STROKE BALL SPLINE

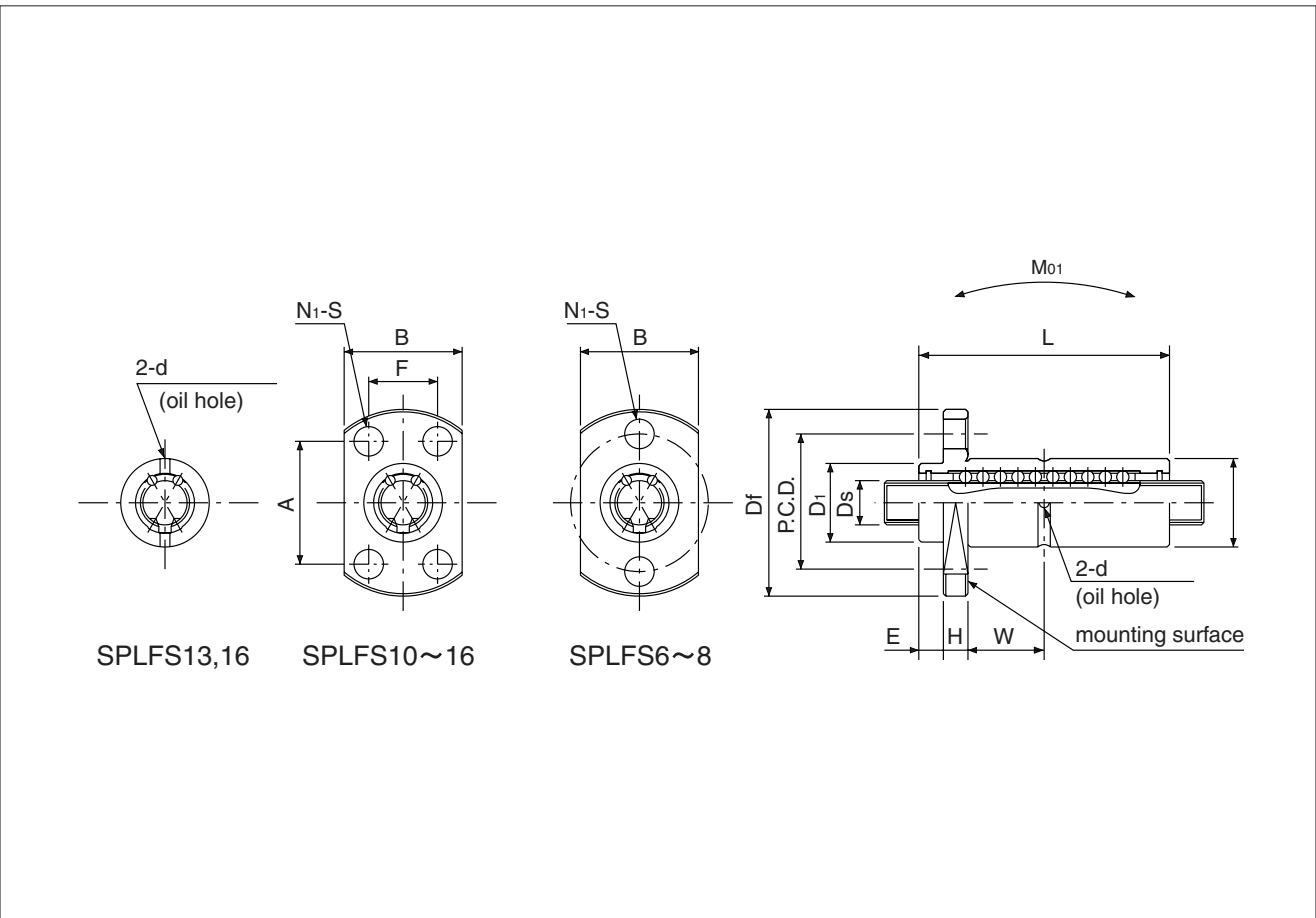

W	d	Ds		basic torque rating		basic load rating		allowable static moment		second cross-sectional moment	mounting surface	mass		size
				dynamic	static	dynamic	static	M01	M02			nut	shaft	
			tolerance	C _T	C _{0T}	C	C ₀							
12.7	1.2	6	0/-12	1.5	2.4	1.8	3.0	11.2	45	5.9 × 10	1.97 × 10	21.5	0.21	6
12.7	1.2	8	0	3.3	5.5	2.02	3.37	13.1	52	1.9 × 10 ²	4.76 × 10	27.0	0.38	8
16.7	1.5	10	-15	6.5	10.9	3.21	5.35	25.6	102	4.61 × 10 ²	9.22 × 10	47.7	0.6	10
15.2	1.5	13	0	27.6	50.7	4.15	7.6	38.8	155	1.38 × 10 ³	2.13 × 10 ²	75.3	1.0	13
18.2	2.0	16	-18	62.8	115	7.66	14	88.3	353	2.98 × 10 ³	3.73 × 10 ²	123.5	1.5	16

1N ≙ 102kgf 1N · m ≙ 0.102kgf · m