

SLIDE TABLE

The NB slide table is a precision table equipped with a slide way. Its high-precision and low-friction characteristics make it well suited for use in electronics automatic-assembly machines and optical measurement devices.

STRUCTURE AND ADVANTAGES

The NB slide table consists of a slide way sandwiched between an accurately machined table and a bed. Stopper is provided within the table.

High Accuracy:

The mounting surfaces of the table and bed are precision finished to ensure high-precision linear motion, resulting in a high-performance slide way.

Low Friction:

Its non-recirculating mechanism provides stable motion from low to high speeds.

Compact and High Rigidity:

Being designed compactly, the NB slide table holds the high load capacity and high-rigidity characteristics.

No Need for Adjustment:

The table is carefully assembled so that the accuracy and pre-load are optimized, so it can be used immediately without any further adjustment.

Ease of Mounting:

Standardized mounting holes are provided in the table and bed. High-precision linear motion can be achieved simply by mounting.

Figure H-25 Structure of SVT Type Slide Table

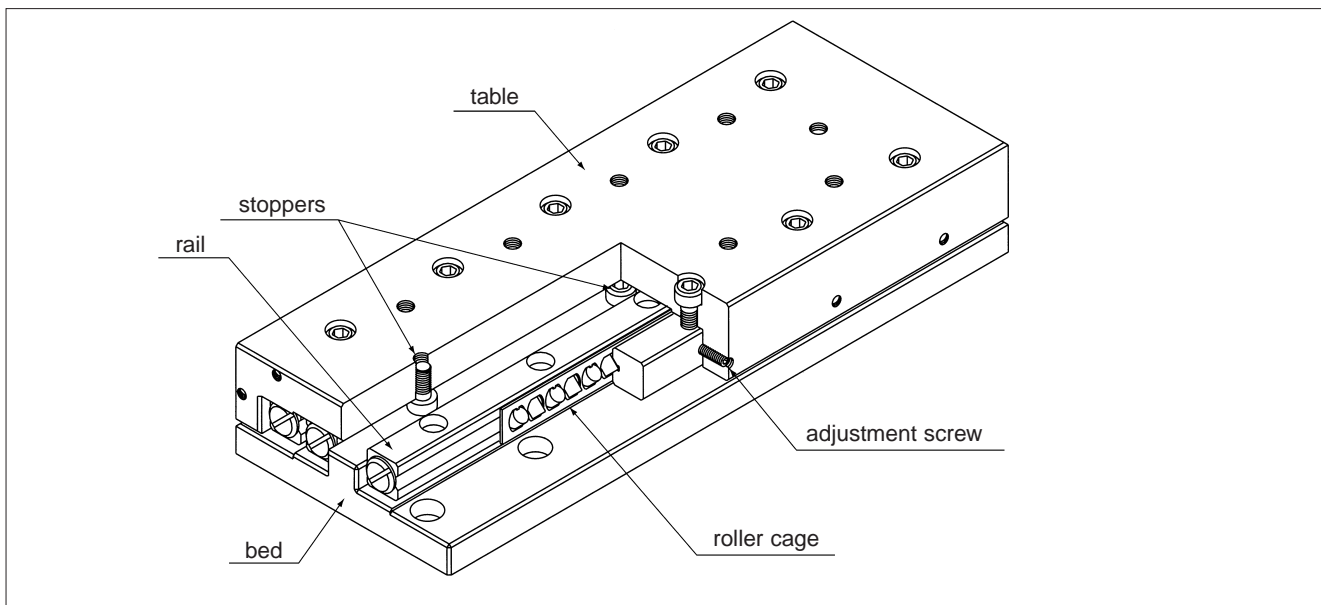

TYPE

SVT·SVTS Type

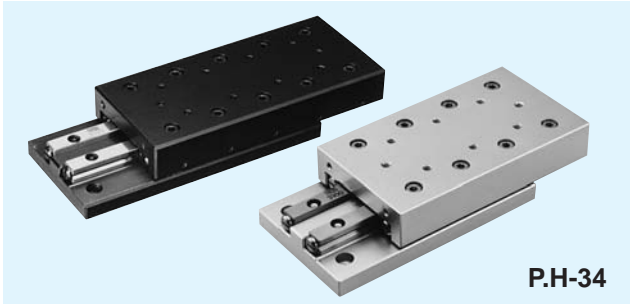

In the SVT type slide table, the slide way is sandwiched between an accurately machined steel tabletop and bed. In the SVTS type, an anti-corrosion SVS type slide way is sandwiched between an accurately machined aluminum tabletop and bed.

SYT·SYTS Type



The SYT/SYTS type is a thin, compact slide table. Either tapped or counterbore type is available. The anti-corrosion SYTS type slide table is fabricated with all stainless steel components, making it suitable for use in clean rooms.

ACCURACY

The motion accuracy of a slide table is measured by placing indicators at the centers of the top and side surfaces of the table, as illustrated in Figure H-26. It is expressed in terms of the indicator deflections when the table is moved to the right and left under no-load conditions.

Figure H-26 Accuracy Measurement Method

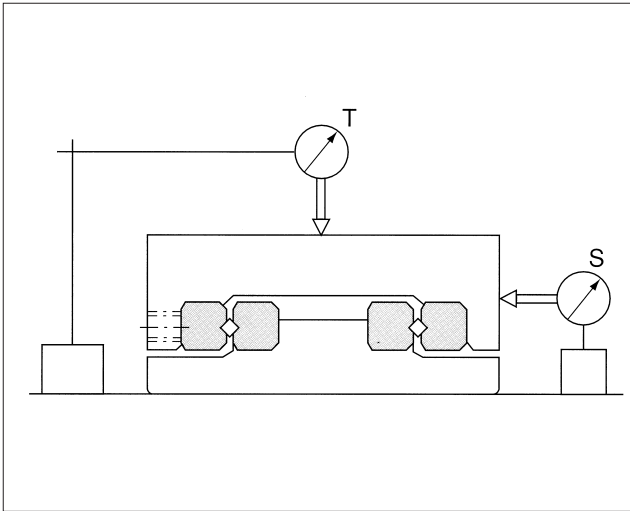

RATED LIFE

The life of an NB slide table is calculated using the following equations.

Travel life :

$$L = \left(\frac{f_T \cdot C}{f_W \cdot P} \right)^{10/3} \cdot 50$$

L : travel life (km) f_T : temperature coefficient
 f_W : load coefficient
 ※ Refer to page Eng. 5 for the coefficients.

Life time :

$$L_h = \frac{L \cdot 10^3}{2 \cdot \ell \cdot s \cdot n_1 \cdot 60}$$

L_h : life time (hr) ℓ : stroke length (m)
 n_1 : number of strokes per minute (cpm)

NOTES ON OPERATION

Careful Handling:

Dropping a table may result in scratches or dents on the raceway surface, preventing smooth motion and reducing the life. Care should be exercised when handling a table.

Dust Prevention:

Dust and foreign particles can affect the accuracy and lifetime of a slide table. A slide table used in a hostile environment should be protected with a cover.

Lubrication:

Lithium soap lubrication is applied prior to shipment, so a table can be used immediately upon delivery. Periodic application of a similar lubricant should be necessary depending on the operating conditions.

Cage Slippage:

The cage can slip under high-speed motion, unbalanced-loading, and vibrating conditions. The motion speed of a slide table should be kept under 30 m/min.

Adjustment/Installation Screws:

The NB slide table is adjusted to achieve optimum accuracy and pre-load. The adjustment screw and tracking-bed installation screws should not be changed.

Allowable Load

The allowable load is a load under which the sum of elastic deformations of the rolling element and the raceways in the contact area subject to the maximum contact stress is small enough to guarantee smooth rolling movement. Where very smooth and highly accurate liner motion is required, make sure to use the product within the allowable load values.

SPECIAL REQUIREMENTS

NB can fabricate tables to meet special requirements, including tables with a micrometer head and tables for projectors. Contact NB for further information.

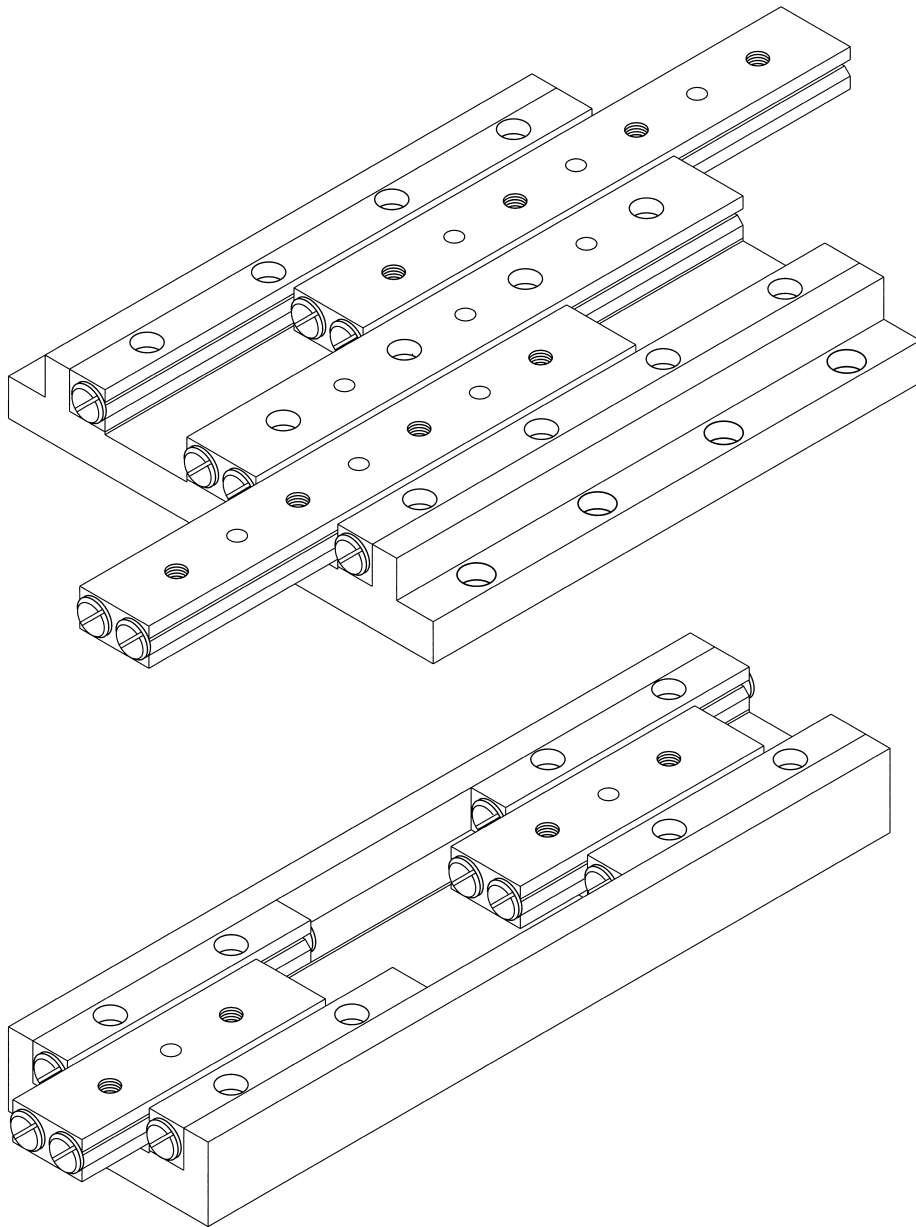

SVT TYPE

— SVT1/SVT2 —

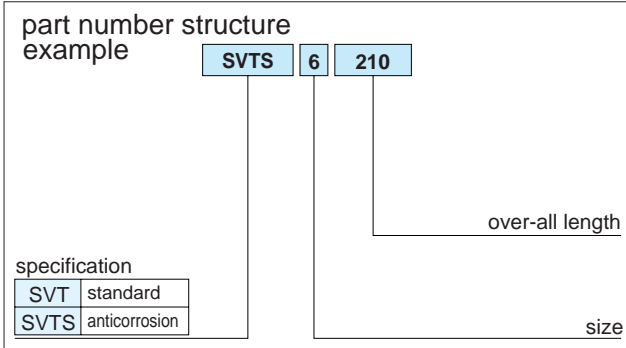
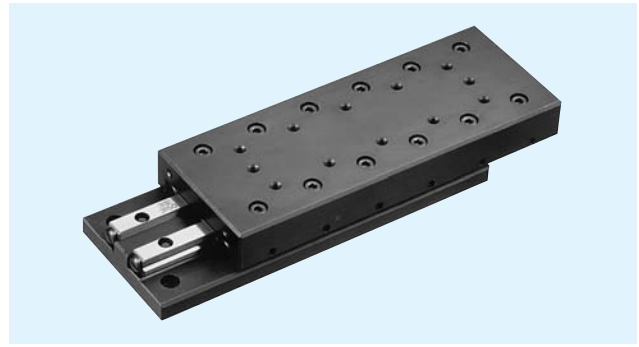

part number		stroke mm	major dimensions				table-top mounting-hole dimensions					table-end mounting-hole dimensions						
standard	anticorrosion		A mm	B mm	L mm	b mm	P ₁ mm	S ₁	ℓ _a mm	N mm	M×P mm	h ₁ mm	h ₂ mm	t ₁ mm	t ₂ mm	S ₂	ℓ _b mm	P ₂ mm
SVT1025	SVTS1025	12			25					—								
1035	1035	18			35					1×10								
1045	1045	25			45					2×10								
1055	1055	32	17 ^{±0.1}	30 ^{-0.2/-0.4}	55	11	10	M2	4	12.5	3×10	12	—	2.5	—	M2	6	22
1065	1065	40			65						4×10							
1075	1075	45			75						5×10							
1085	1085	50			85						6×10							
SVT2035	SVTS2035	18			35					—								
2050	2050	30			50					1×15								
2065	2065	40			65					2×15								
2080	2080	50			80					3×15								
2095	2095	60			95					4×15								
2110	2110	70	21 ^{±0.1}	40 ^{-0.2/-0.4}	110	14	15	M3	6	17.5	5×15	16	—	3.4	—	M2	6	30
2125	2125	80			125						6×15							
2140	2140	90			140						7×15							
2155	2155	100			155						8×15							
2170	2170	110			170						9×15							
2185	2185	120			185						10×15							

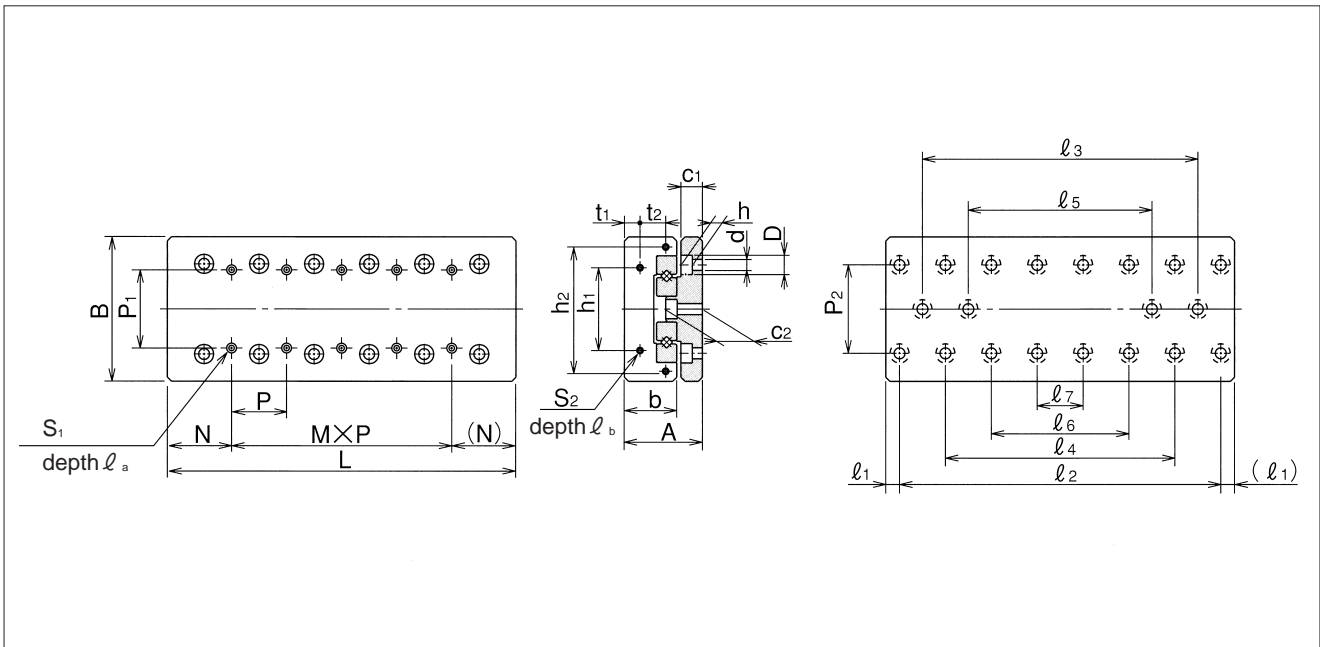

bed-surface mounting-hole dimensions										accuracy※		basic load rating		allowable load F N	allowable static moment			mass		size
d×D×h mm	C ₁ mm	C ₂ mm	l ₁ mm	l ₂ mm	l ₃ mm	l ₄ mm	l ₅ mm	l ₆ mm	l ₇ mm	T μm	S μm	C N	Co N		M _P N·m	M _V N·m	M _R N·m	SVT g	SVTS g	
2.5×4.5×2.5	5.5	9	3.5	18	-	-	-	-	-	2	4	464	476	158	1.79	1.47	3.22	82	36	1025
				28	-	-	-	-	-	2	4	805	952	316	3.08	3.5	6.45	120	50	1035
				38	-	-	-	-	-	2	4	959	1,190	396	6.98	6.4	8.06	158	69	1045
				48	-	28	-	-	-	2	5	1,100	1,420	475	9.53	8.81	9.68	190	83	1055
				58	-	38	-	-	-	2	5	1,240	1,660	554	12.4	11.6	11.2	225	98	1065
				68	-	48	-	-	-	2	5	1,510	2,140	712	19.3	18.3	14.5	260	113	1075
3.5×6.5×3.5	6.5	10.9	5	78	-	58	-	-	-	2	5	1,650	2,380	792	23.4	22.3	16.1	295	128	1085
				25	-	-	-	-	-	2	4	1,090	1,170	390	7.04	5.78	10.5	195	90	2035
				40	-	-	-	-	-	2	4	1,510	1,750	585	12.1	10.7	15.8	280	133	2050
				55	-	-	-	-	-	2	5	1,900	2,340	780	19.1	17.1	21.1	370	175	2065
				70	-	40	-	-	-	2	5	2,620	3,510	1,170	27.4	29.6	31.6	450	220	2080
				85	-	55	-	-	-	2	5	2,950	4,100	1,360	37.4	39.9	36.9	540	250	2095
				100	-	70	-	-	-	3	6	3,280	4,680	1,560	61.7	58.1	42.2	630	285	2110
				115	-	85	-	-	-	3	6	3,590	5,270	1,750	76.1	72.1	47.5	720	330	2125
130	-	100	-	70	-	3	6	4,210	6,440	2,140	92	95.9	58.1	800	360	2140				
145	-	115	-	85	-	3	6	4,500	7,030	2,340	109	113	63.3	880	400	2155				
160	-	130	-	100	-	3	7	4,790	7,610	2,530	148	143	68.6	970	440	2170				
175	-	145	-	115	85	3	7	5,080	8,200	2,730	170	164	73.9	1,060	480	2185				

※ Refer to Figure H-26 (page H-31) for accuracy T and S.

1N≒0.102kgf 1N·m≒0.102kgf·m

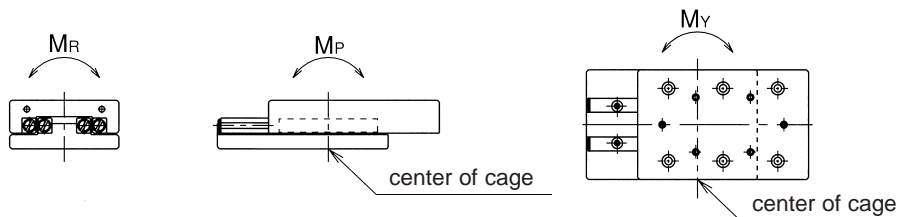

SVT TYPE

— SVT3/SVT4 —

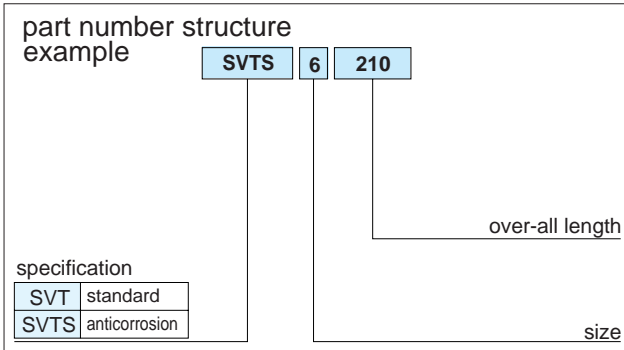
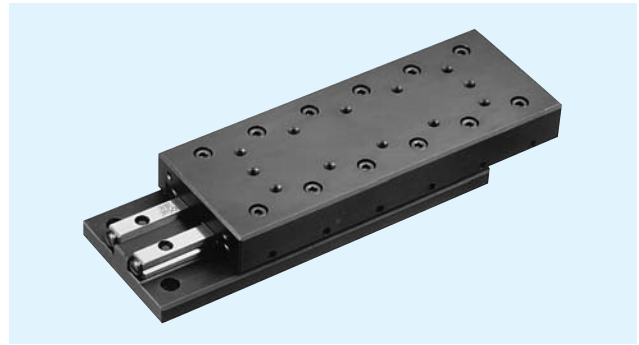

part number		stroke mm	major dimensions				table-top mounting-hole dimensions					table-end mounting-hole dimensions						
standard	anticorrosion		A mm	B mm	L mm	b mm	P ₁ mm	S ₁	ℓ _a mm	N mm	M×P mm	h ₁ mm	h ₂ mm	t ₁ mm	t ₂ mm	S ₂	ℓ _b mm	P ₂ mm
SVT3055	SVTS3055	30			55					—								
3080	3080	45			80					1×25								
3105	3105	60			105					2×25								
3130	3130	75			130					3×25								
3155	3155	90			155					4×25								
3180	3180	105	28 ^{±0.1}	60 ^{±0.1}	180	18.5	25	M4	8	27.5	5×25	40	—	5.5	—	M3	6	40
3205	3205	130			205					6×25								
3230	3230	155			230					7×25								
3255	3255	180			255					8×25								
3280	3280	205			280					9×25								
3305	3305	230			305					10×25								
SVT4085	SVTS4085	50			85					—								
4125	4125	75			125					1×40								
4165	4165	105			165					2×40								
4205	4205	130			205					3×40								
4245	4245	155	35 ^{±0.1}	80 ^{±0.1}	245	24	40	M5	10	42.5	4×40	55	—	6.5	—	M3	6	55
4285	4285	185			285					5×40								
4325	4325	210			325					6×40								
4365	4365	235			365					7×40								
4405	4405	265			405					8×40								

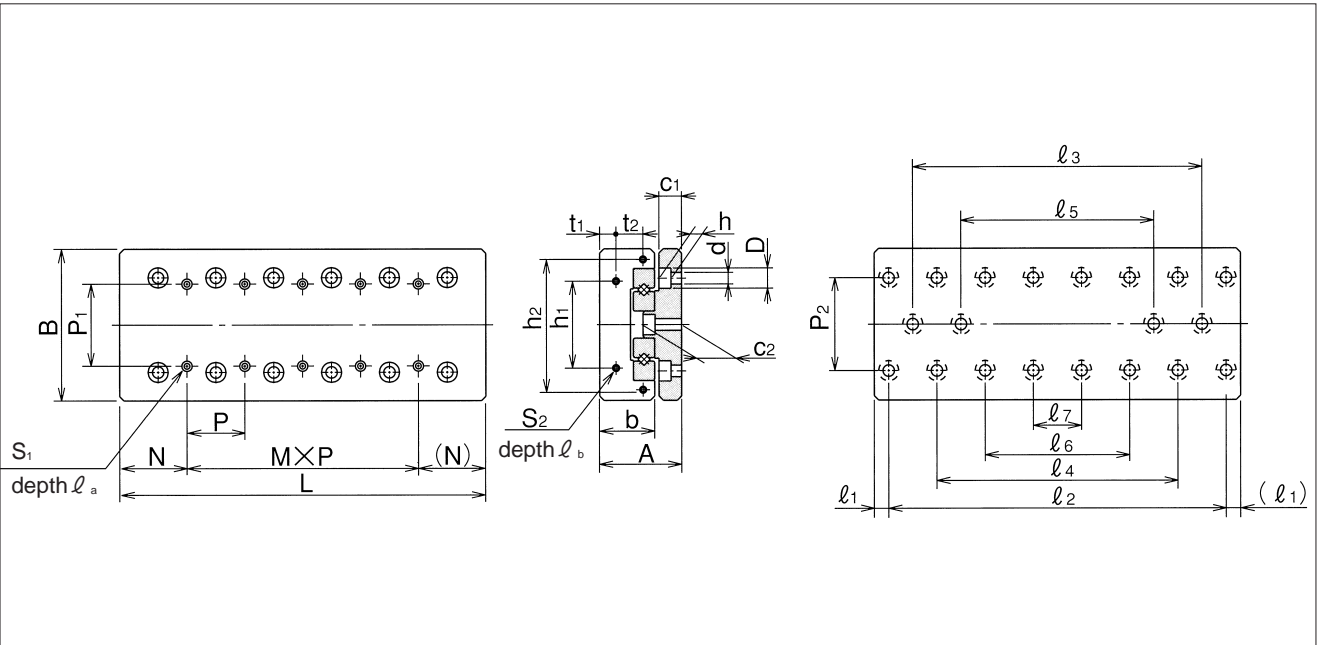

bed-surface mounting-hole dimensions										accuracy※		basic load rating		allowable load F N	allowable static moment			mass		size		
d×D×h mm	c ₁ mm	c ₂ mm	l ₁ mm	l ₂ mm	l ₃ mm	l ₄ mm	l ₅ mm	l ₆ mm	l ₇ mm	T μm	S μm	C N	Co N		M _P N·m	M _Y N·m	M _R N·m	SVT g	SVTS g			
4.5×8×4.5	9	15	10	35	—	—	—	—	—	2	5	3,490	3,890	1,290	19.4	22.2	54.5	640	300	3055		
				60	—	—	—	—	—	—	2	5	5,230	6,490	2,160	53.0	58.0	90.9	955	440	3080	
				85	—	—	—	—	—	—	—	3	6	6,030	7,780	2,590	103	95.7	109	1,250	580	3105
				110	—	—	—	—	—	—	—	3	6	7,560	10,300	3,450	170	160	145	1,570	715	3130
				135	85	—	—	—	—	—	—	3	6	9,000	12,900	4,320	210	220	181	1,850	850	3135
				160	110	—	—	—	—	—	—	3	7	10,300	15,500	5,180	302	314	218	2,150	990	3180
				185	135	85	—	—	—	—	—	3	7	11,000	16,800	5,610	355	367	236	2,450	1,130	3205
				210	160	110	—	—	—	—	—	3	7	11,700	18,100	6,040	472	455	254	2,740	1,270	3230
				235	185	135	—	—	—	—	—	3	7	12,900	20,700	6,910	537	552	290	3,040	1,410	3255
				260	210	160	110	—	—	—	—	3	7	13,600	22,000	7,340	606	622	309	3,360	1,540	3280
285	235	185	135	—	—	—	—	3	7	14,200	23,300	7,770	757	735	372	3,660	1,680	3305				
5.5×10×5.4	10.5	18	10	65	—	—	—	—	—	2	5	7,110	7,920	2,640	96.0	84.9	159	1,700	780	4085		
				105	—	—	—	—	—	—	3	6	10,600	13,200	4,400	217	199	265	2,500	1,140	4125	
				145	—	—	—	—	—	—	—	3	7	13,800	18,400	6,160	296	316	371	3,300	1,510	4165
				185	105	—	—	—	—	—	—	3	7	16,800	23,700	7,920	488	513	477	4,100	1,870	4205
				225	145	—	—	—	—	—	—	3	7	19,700	29,000	9,680	729	759	584	4,900	2,240	4245
				265	185	—	—	—	—	—	—	3	7	22,400	34,300	11,400	1,010	1,050	690	5,700	2,600	4285
				305	225	145	—	—	—	—	—	4	8	25,100	39,600	13,200	1,350	1,390	796	6,500	3,000	4325
				345	265	185	—	—	—	—	—	4	8	27,600	44,800	14,900	1,730	1,780	902	7,300	3,300	4365
385	305	225	—	—	—	—	—	4	8	28,900	47,500	15,800	2,160	2,100	955	8,100	3,700	4405				

※ Refer to Figure H-26 (page H-31) for accuracy T and S.

1N≒0.102kgf 1N·m≒0.102kgf·m

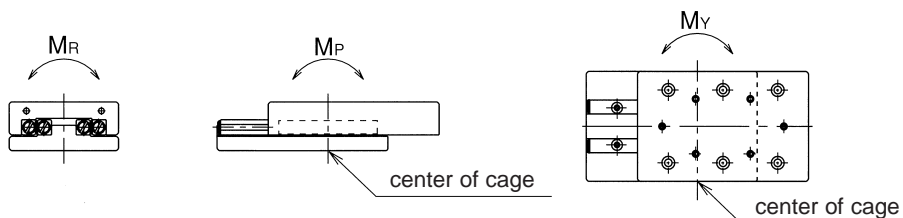

SVT TYPE

— SVT6/SVT9 —

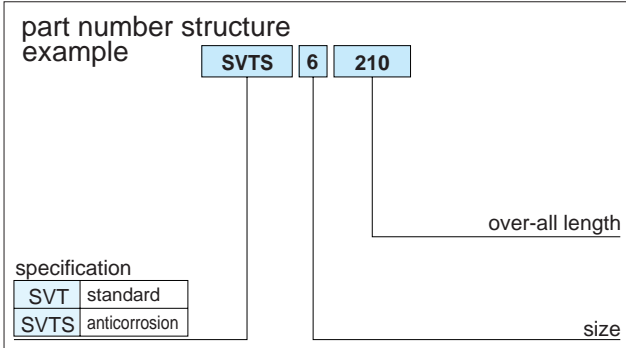
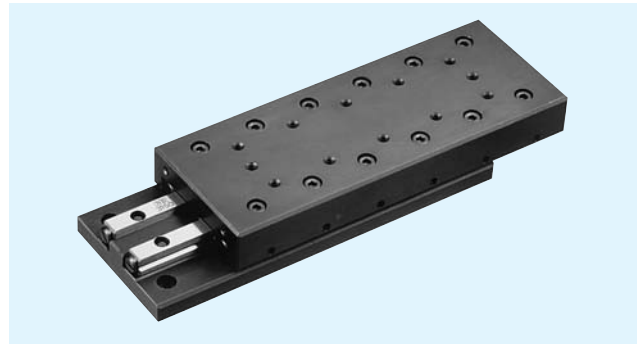

part number		stroke mm	major dimensions				table-top mounting-hole dimensions					table-end mounting-hole dimensions						
standard	anticorrosion		A mm	B mm	L mm	b mm	P ₁ mm	S ₁	ℓ _a mm	N mm	M×P mm	h ₁ mm	h ₂ mm	t ₁ mm	t ₂ mm	S ₂	ℓ _b mm	P ₂ mm
SVT6110	SVTS6110	60			110					—								
6160	6160	95			160					1×50								
6210	6210	130			210					2×50								
6260	6260	165			260					3×50								
6310	6310	200	45 ^{±0.1}	100 ^{±0.1}	310	31	50	M6	12	55	4×50	60	92	8	15	M4	8	60
6360	6360	235			360						5×50							
6410	6410	265			410						6×50							
6460	6460	300			460						7×50							
6510	6510	335			510						8×50							
SVT9210	—	130			210					—								
9310	—	180			310					1×100								
9410	—	350			410					2×100								
9510	—	450			510					3×100								
9610	—	550	60 ^{±0.1}	145 ^{±0.2}	610	43	85	M8	16	105	4×100	90	135	11	20	M4	8	90
9710	—	650			710						5×100							
9810	—	750			810						6×100							
9910	—	850			910						7×100							
91010	—	950			1,010						8×100							

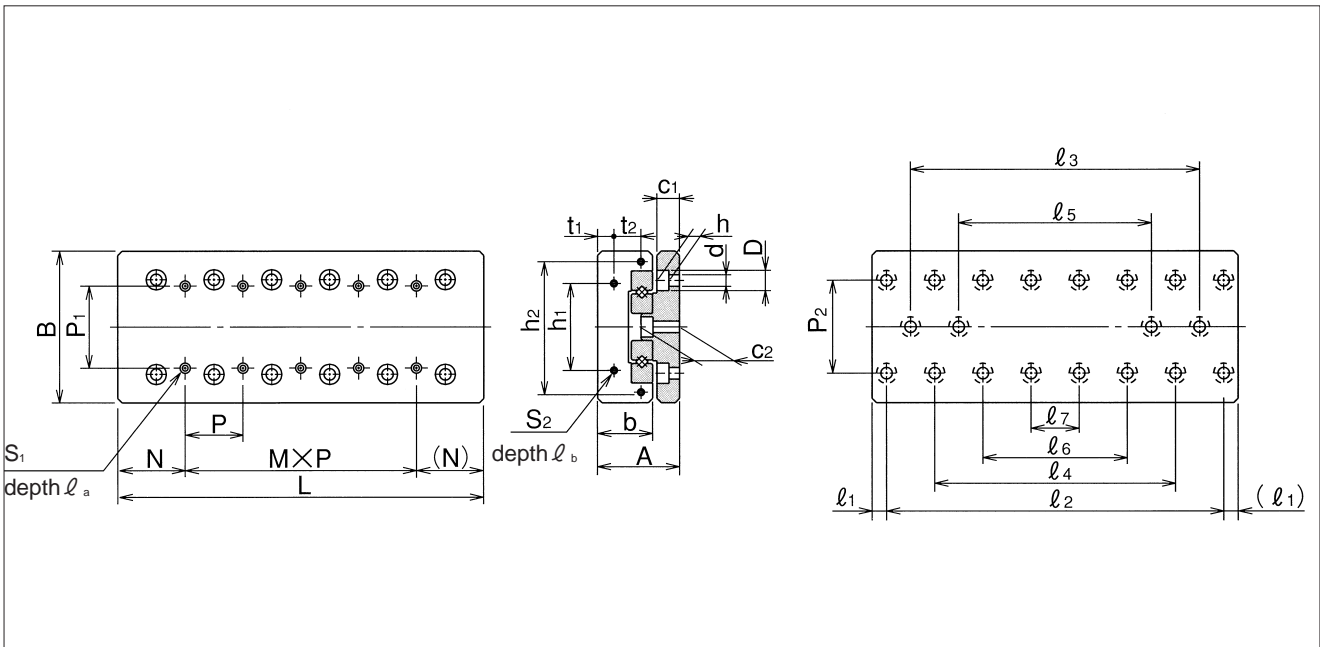

bed-surface mounting-hole dimensions										accuracy※		basic load rating		allowable load F N	allowable static moment			mass		size
d×D×h mm	c ₁ mm	c ₂ mm	l ₁ mm	l ₂ mm	l ₃ mm	l ₄ mm	l ₅ mm	l ₆ mm	l ₇ mm	T μm	S μm	C N	Co N		M _P N·m	M _Y N·m	M _R N·m	SVT g	SVTS g	
7×11.5×7	13	23	10	90	—	—	—	—	—	3	6	16,500	17,700	5,910	260	230	400	3,280	1,705	6110
				140	—	—	—	—	—	3	6	24,700	29,600	9,860	588	539	666	4,820	2,480	6160
				190	90	—	—	—	—	3	7	32,200	41,400	13,800	1,040	978	933	6,270	3,255	6210
				240	140	—	—	—	—	3	7	39,200	53,200	17,700	1,630	1,540	1,200	7,740	4,030	6260
				290	190	—	—	—	—	3	7	45,800	65,100	21,600	2,340	2,240	1,460	9,200	4,805	6310
				340	240	140	—	—	—	4	8	52,200	76,900	25,600	2,750	2,850	1,730	10,740	5,580	6360
				390	290	190	—	—	—	4	8	58,400	88,800	29,500	3,660	3,770	2,000	12,190	6,355	6410
				440	340	240	—	—	—	4	8	64,400	100,000	33,500	4,700	4,830	2,260	13,800	7,130	6460
490	390	290	190	—	—	4	8	70,200	112,000	37,400	5,870	6,010	2,530	15,300	7,905	6510				
9×14×9	16	29	55	100	—	—	—	—	—	3	7	51,100	56,500	18,800	1,610	1,440	2,030	12,520	—	9210
				200	—	—	—	—	—	3	7	79,300	98,900	32,900	3,150	3,360	3,560	17,950	—	9310
				300	100	—	—	—	—	4	8	79,300	98,900	32,900	4,110	3,840	3,560	23,950	—	9410
				400	200	—	—	—	—	4	8	96,600	127,000	42,300	6,420	6,080	4,580	30,090	—	9510
				500	300	100	—	—	—	4	9	112,000	155,000	51,700	7,760	8,090	5,600	35,990	—	9610
				600	400	200	—	—	—	4	9	128,000	183,000	61,100	10,800	11,200	6,620	41,890	—	9710
				700	500	300	100	—	—	5	10	136,000	197,000	65,800	14,400	13,900	7,130	47,790	—	9810
				800	600	400	200	—	—	5	10	151,000	226,000	75,200	18,500	17,900	8,140	53,690	—	9910
				900	700	500	300	100	—	5	10	165,000	254,000	84,600	23,100	22,400	9,160	59,590	—	91010

※ Refer to Figure H-26 (page H-31) for accuracy T and S.

1N≒0.102kgf 1N·m≒0.102kgf·m

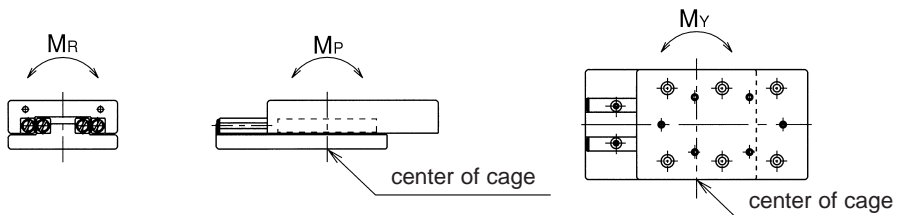

SYT TYPE

– SYT1/SYT2 –

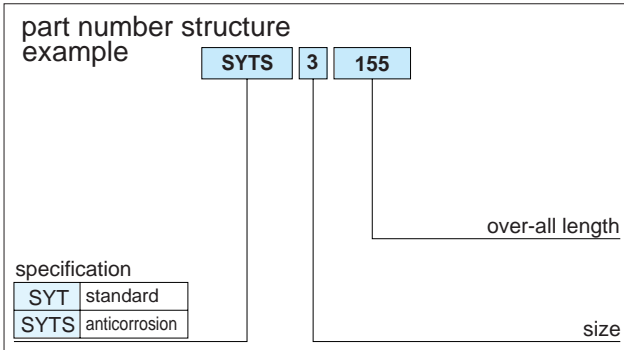
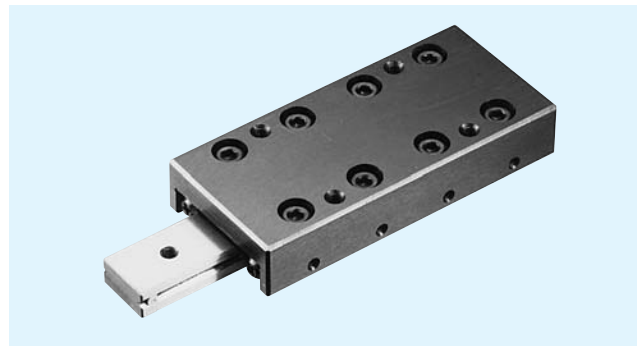

part number		stroke mm	major dimensions						table-top mounting-hole dimensions		
standard	anticorrosion		A mm	B ₁ mm	L mm	b mm	B ₂ mm	c mm	P ₁ mm	S ₁	ℓ mm
SYT1025	SYTS1025	12			25						
1035	1035	18			35						
1045	1045	25			45						
1055	1055	32	8 ^{±0.1}	20 ^{±0.1}	55	7.5	6.6	4	14	M2.6	3.5
1065	1065	40			65						
1075	1075	45			75						
1085	1085	50			85						
SYT2035	SYTS2035	18			35						
2050	2050	30			50						
2065	2065	40			65						
2080	2080	50	12 ^{±0.1}	30 ^{±0.1}	80	11.5	12	6	22	M3	5.5
2095	2095	60			95						
2110	2110	70			110						
2125	2125	80			125						

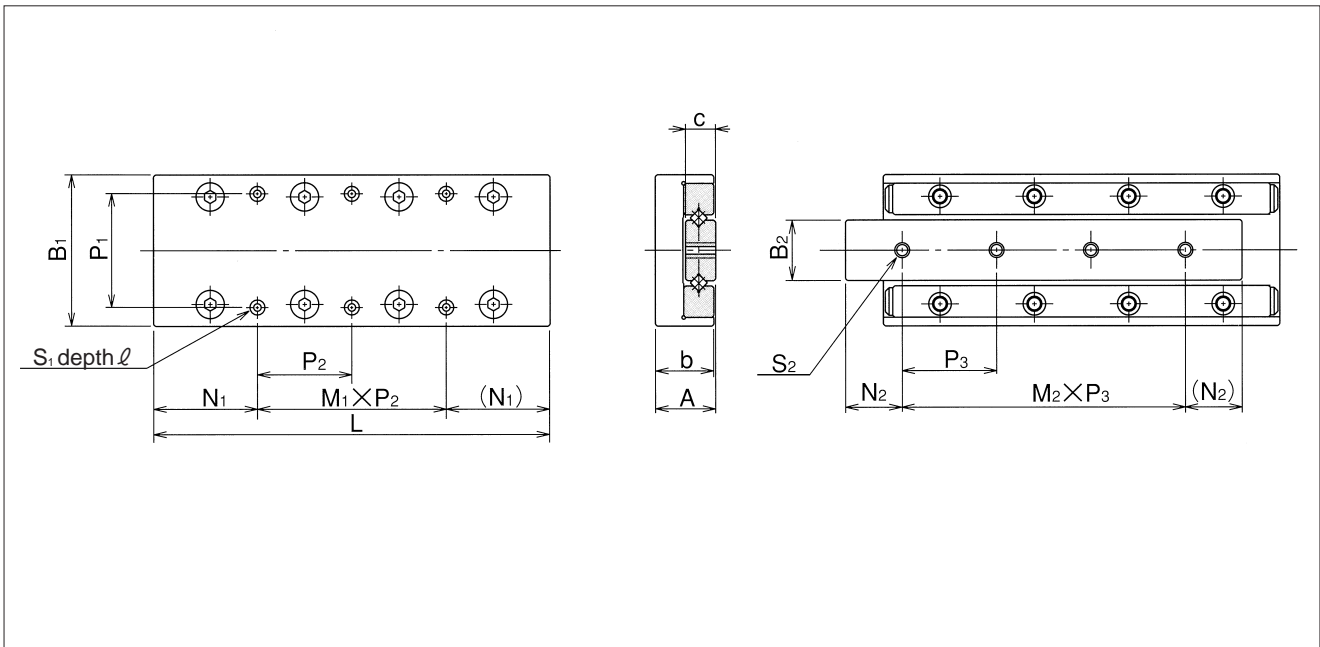

		center rail mounting-hole dimensions			accuracy※		basic load rating		allowable load F N	allowable static moment			mass g	size
N ₁ mm	M ₁ × P ₂ mm	S ₂	N ₂ mm	M ₂ × P ₃ mm	T μm	S μm	C N	C ₀ N		M _P N·m	M _V N·m	M _R N·m		
3.5	1 × 18	M2.6	5	2 × 7.5	2	4	464	476	158	1.79	1.47	1.79	22	1025
3.5	1 × 28		7.5	2 × 10	2	4	805	952	316	3.08	3.50	3.58	33	1035
12.5	1 × 20		7.5	3 × 10	2	5	959	1,190	396	6.98	6.40	4.48	42	1045
12.5	1 × 30		7.5	4 × 10	2	5	1,100	1,420	475	9.53	8.81	5.37	52	1055
12.5	2 × 20		7.5	5 × 10	2	5	1,240	1,660	554	12.4	11.6	6.27	63	1065
22.5	1 × 30		7.5	6 × 10	2	5	1,510	2,140	712	19.3	18.3	8.06	72	1075
12.5	2 × 30		7.5	7 × 10	2	5	1,650	2,380	792	23.4	22.3	8.96	83	1085
3.5	1 × 28	M3	7.5	1 × 20	2	4	1,090	1,170	390	7.04	5.78	7.63	79	2035
3.5	1 × 43		10	2 × 15	2	4	1,510	1,750	585	12.1	10.7	11.4	113	2050
17.5	1 × 30		10	3 × 15	2	5	1,900	2,340	780	19.1	17.1	15.2	150	2065
17.5	1 × 45		10	4 × 15	2	5	2,620	3,510	1,170	27.4	29.6	22.8	185	2080
17.5	2 × 30		10	5 × 15	2	5	2,950	4,100	1,360	37.4	39.9	26.7	215	2095
32.5	1 × 45		10	6 × 15	2	5	3,280	4,680	1,560	61.7	58.1	30.5	255	2110
17.5	2 × 45		10	7 × 15	2	5	3,590	5,270	1,750	76.1	72.1	34.3	295	2125

※ Refer to Figure H-26 (page H-31) for accuracy T and S.

1N ≒ 0.102kgf 1N·m ≒ 0.102kgf·m

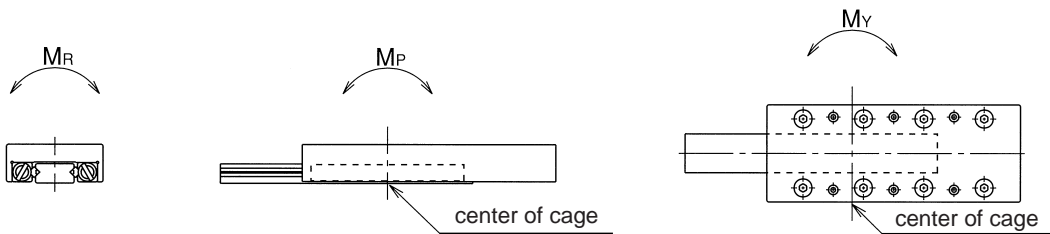

SYT TYPE

– SYT3 –

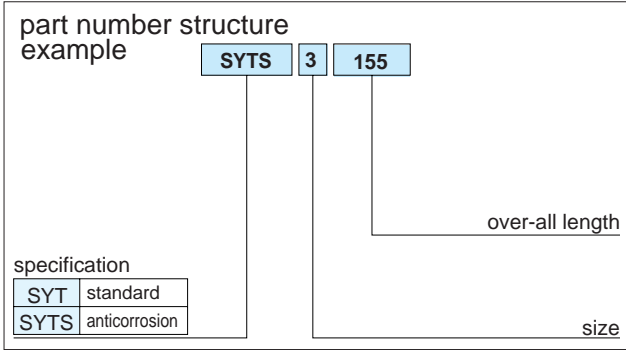
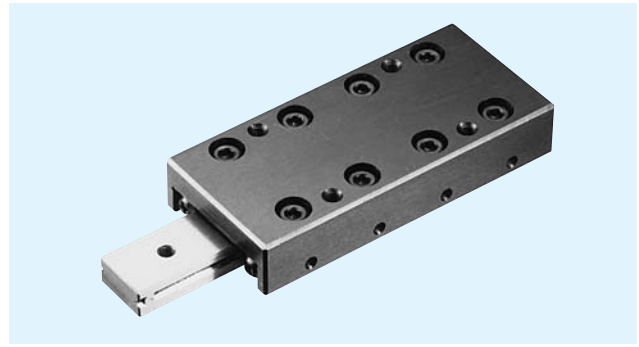

part number		stroke mm	major dimensions						table-top mounting-hole dimensions		
standard	anticorrosion		A mm	B ₁ mm	L mm	b mm	B ₂ mm	c mm	P ₁ mm	S ₁	ℓ mm
SYT3055	SYTS3055	30			55						
3080	3080	45			80						
3105	3105	60			105						
3130	3130	75	16 ^{±0.1}	40 ^{±0.1}	130	15.5	16	8	30	M4	7.5
3155	3155	90			155						
3180	3180	105			180						
3205	3205	130			205						

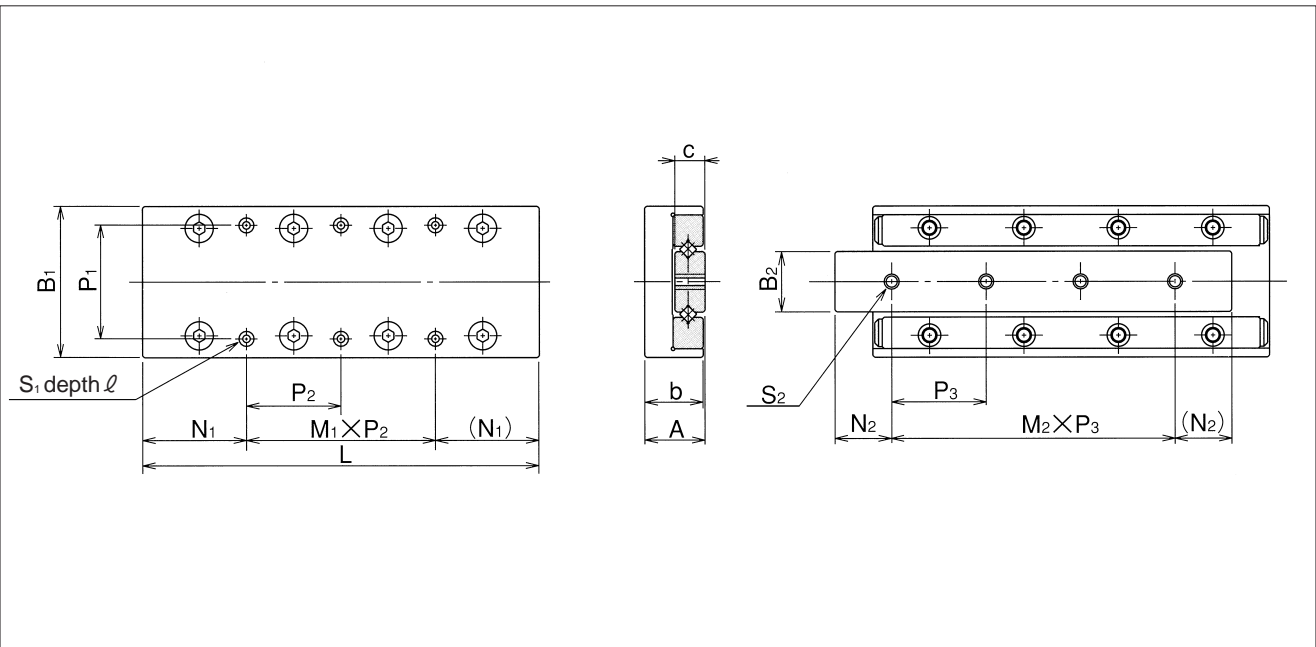

		center rail mounting-hole dimensions			accuracy※		basic load rating		allowable load F N	allowable static moment			mass g	size
N ₁ mm	M ₁ × P ₂ mm	S ₂	N ₂ mm	M ₂ × P ₃ mm	T μm	S μm	dynamic C N	static C ₀ N		M _P N·m	M _V N·m	M _R N·m		
7.5	1 × 40	M4	10	1 × 35	2	5	3,490	3,890	1,290	19.4	22.2	33.8	225	3055
7.5	1 × 65		15	2 × 25	2	5	5,230	6,490	2,160	53.0	58.0	56.4	340	3080
27.5	1 × 50		15	3 × 25	3	5	6,030	7,790	2,590	103	95.7	67.7	440	3105
27.5	1 × 75		15	4 × 25	3	5	7,560	10,300	3,450	170	160	90.3	560	3130
27.5	2 × 50		15	5 × 25	3	5	9,000	12,900	4,320	210	220	112	655	3155
52.5	1 × 75		15	6 × 25	3	5	10,300	15,500	5,180	302	314	135	770	3180
27.5	2 × 75		15	7 × 25	3	5	11,000	16,800	5,610	355	367	146	880	3205

※ Refer to Figure H-26 (page H-31) for accuracy T and S.

1N ≒ 0.102kgf 1N·m ≒ 0.102kgf·m

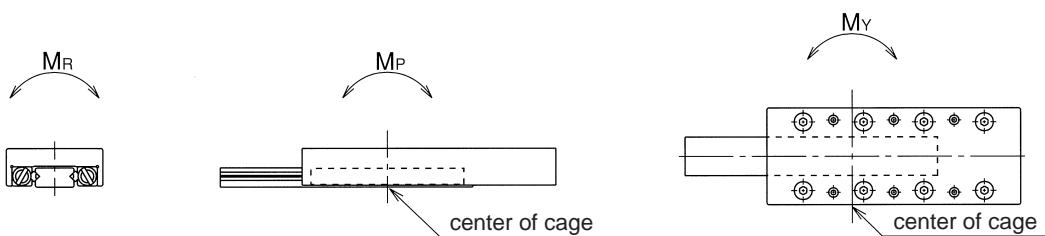

SYT-D TYPE

– SYT1/SYT2 –

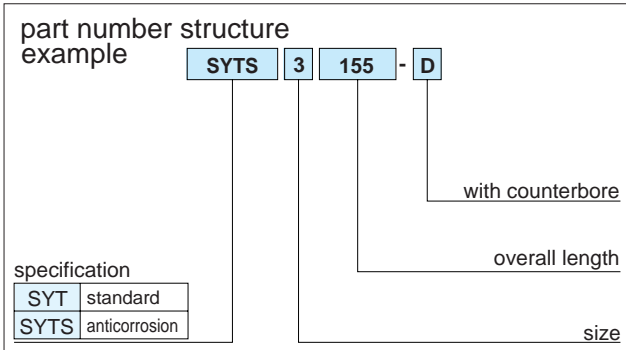
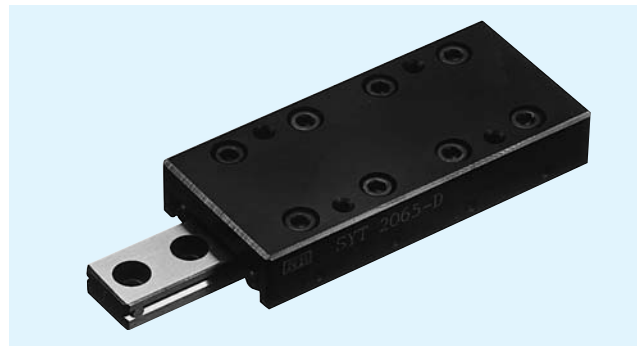

part number		stroke mm	major dimensions						table-top mounting-hole dimensions			
standard	anticorrosion		A mm	B ₁ mm	L mm	b mm	B ₂ mm	c mm	P ₁ mm	S ₁	∅ mm	N ₁ mm
SYT1025-D	SYTS1025-D	12			25							3.5
1035-D	1035-D	18			35							3.5
1045-D	1045-D	25			45							12.5
1055-D	1055-D	32	8 ^{±0.1}	20 ^{±0.1}	55	7.5	6.6	4	14	M2.6	3.5	12.5
1065-D	1065-D	40			65							12.5
1075-D	1075-D	45			75							22.5
1085-D	1085-D	50			85							12.5
SYT2035-D	SYTS2035-D	18			35							3.5
2050-D	2050-D	30			50							3.5
2065-D	2065-D	40			65							17.5
2080-D	2080-D	50	12 ^{±0.1}	30 ^{±0.1}	80	11.5	12.0	6	22	M3	5.5	17.5
2095-D	2095-D	60			95							17.5
2110-D	2110-D	70			110							32.5
2125-D	2125-D	80			125							17.5

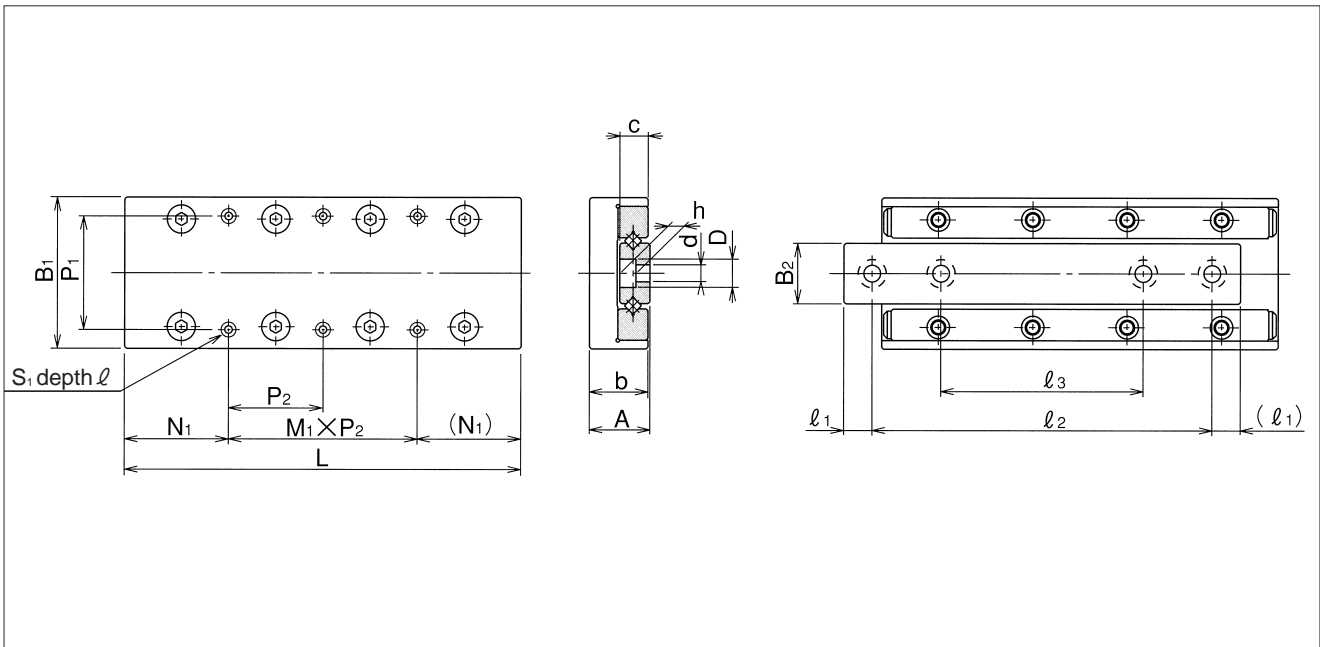

$M_1 \times P_2$ mm	center rail mounting-hole dimensions					accuracy※		basic load rating		allowable load F N	allowable static moment			mass g	size
	$d \times D \times h$ mm	l_1 mm	l_2 mm	l_3 mm	T μm	S μm	C N	Co N	M_p N·m		M_v N·m	M_r N·m			
1×18	$2.5 \times 4.1 \times 2.2$	3.5	18	—	2	4	464	476	158	1.79	1.47	1.79	22	1025	
1×28		5	25	—	2	4	805	952	316	3.08	3.50	3.58	33	1035	
1×20		3.5	38	25	2	5	959	1,190	396	6.98	6.40	4.48	42	1045	
1×30		3.5	48	29	2	5	1,100	1,420	475	9.53	8.81	5.37	52	1055	
2×20		5	55	31	2	5	1,240	1,660	554	12.4	11.6	6.27	63	1065	
1×30		5	65	35	2	5	1,510	2,140	712	19.3	18.3	8.06	72	1075	
2×30		5	75	40	2	5	1,650	2,380	792	23.4	22.3	8.96	83	1085	
1×28	$3.5 \times 6 \times 3.3$	5	25	—	2	4	1,090	1,170	390	7.04	5.78	7.63	79	2035	
1×43		7.5	35	—	2	4	1,510	1,750	585	12.1	10.7	11.4	113	2050	
1×30		5	55	33	2	5	1,900	2,340	780	19.1	17.1	15.2	150	2065	
1×45		5	70	40	2	5	2,620	3,510	1,170	27.4	29.6	22.8	185	2080	
2×30		5	85	45	2	5	2,950	4,100	1,360	37.4	39.9	26.7	215	2095	
1×45		7.5	95	50	2	5	3,280	4,680	1,560	61.7	58.1	30.5	255	2110	
2×45		7.5	110	55	2	5	3,590	5,270	1,750	76.1	72.1	34.3	295	2125	

※ Refer to Figure H-26 (page H-31) for accuracy T and S.

1N \approx 0.102kgf 1N·m \approx 0.102kgf·m

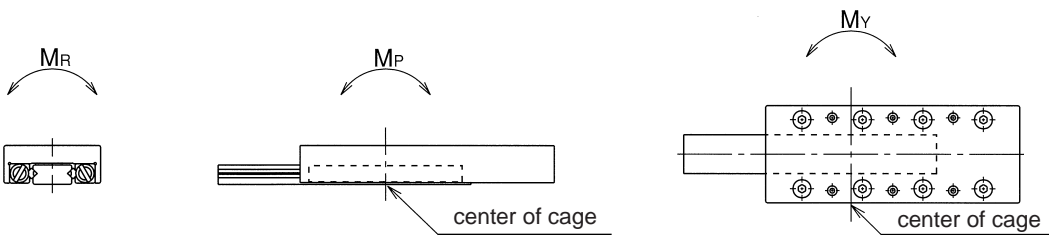

SYT-D TYPE

– SYT3 –

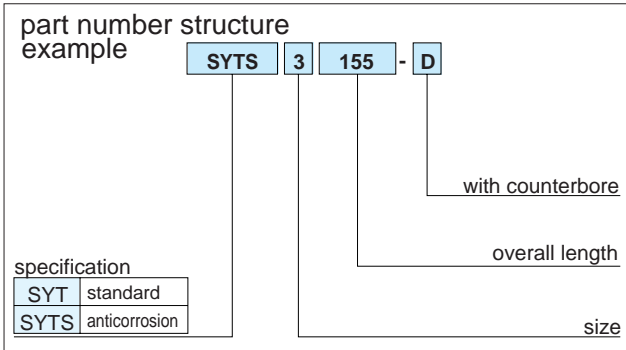
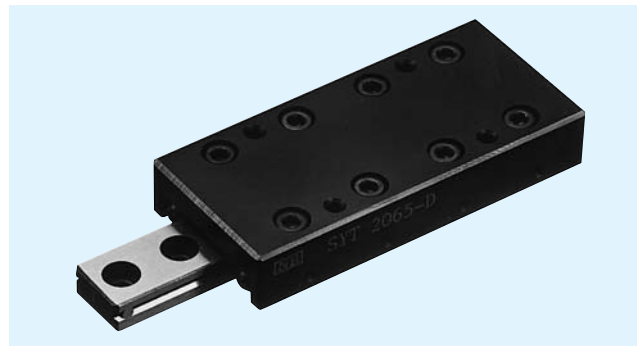

part number		stroke mm	major dimensions						table-top mounting-hole dimensions			
standard	anticorrosion		A mm	B ₁ mm	L mm	b mm	B ₂ mm	c mm	P ₁ mm	S ₁	∅ mm	N ₁ mm
SYT3055-D	SYTS3055-D	30			55							7.5
3080-D	3080-D	45			80							7.5
3105-D	3105-D	60			105							27.5
3130-D	3130-D	75	16 ^{±0.1}	40 ^{±0.1}	130	15.5	16	8	30	M4	7.5	27.5
3155-D	3155-D	90			155							27.5
3180-D	3180-D	105			180							52.5
3205-D	3205-D	130			205							27.5

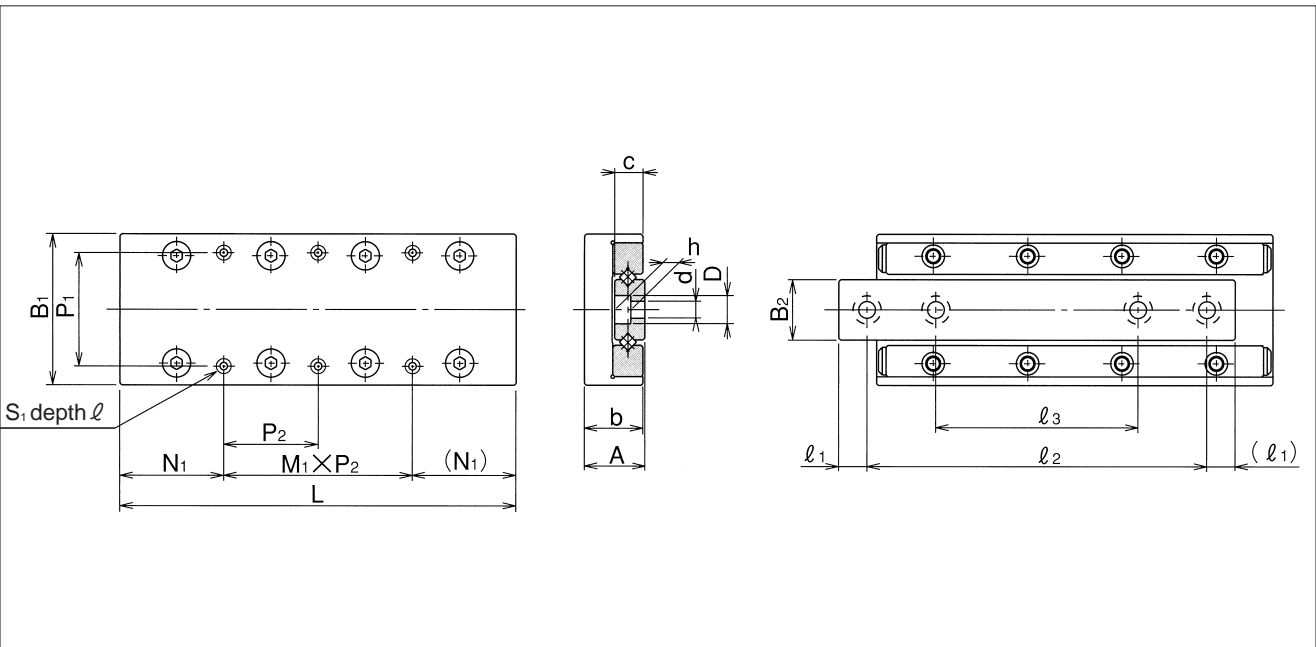

$M_1 \times P_2$ mm	center rail mounting-hole dimensions					accuracy※		basic load rating		allowable load F N	allowable static moment			mass g	size
	$d \times D \times h$ mm	l_1 mm	l_2 mm	l_3 mm	T μm	S μm	dynamic	static	M_p N·m		M_y N·m	M_r N·m			
							C N	C_o N							
1×40	4.5×7.5×4.3	7.5	40	—	2	5	3,490	3,890	1,290	19.4	22.2	33.8	225	3055	
1×65		6	68	43	2	5	5,230	6,490	2,160	53.0	58.0	56.4	340	3080	
1×50		7.5	90	55	3	5	6,030	7,780	2,590	103	95.7	67.7	440	3105	
1×75		7.5	115	65	3	5	7,560	10,300	3,450	170	160	90.3	560	3130	
2×50		7.5	140	95	3	5	9,000	12,900	4,320	210	220	112	655	3155	
1×75		7.5	165	85	3	5	10,300	15,500	5,180	302	314	135	770	3180	
2×75		7.5	190	95	3	5	11,000	16,800	5,610	355	367	146	880	3205	

※ Refer to Figure H-26 (page H-31) for accuracy T and S.

1N≒0.102kgf 1N·m≒0.102kgf·m

