

SW TYPE

– Standard Type –

This type is an inch dimension series mainly used in the U.S.

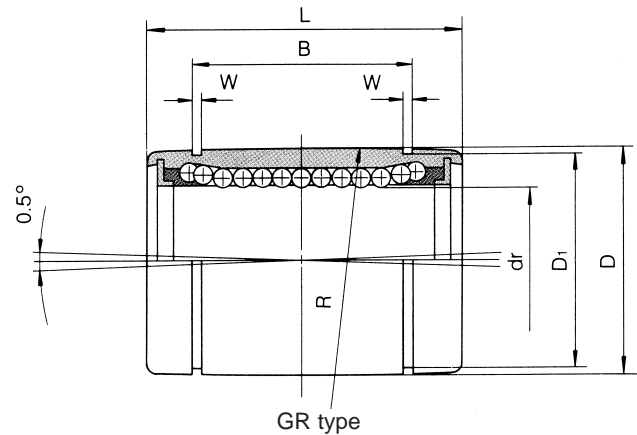
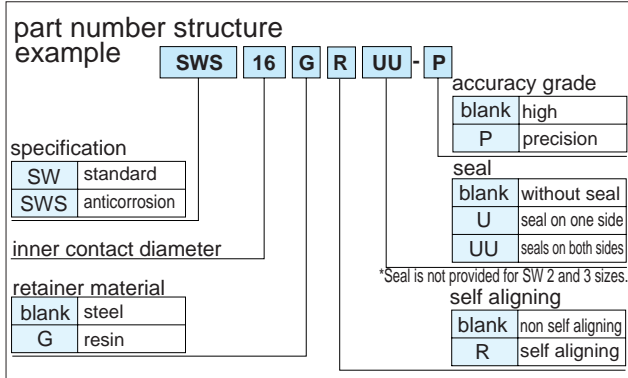

part number				number of ball circuits	dr				D	
standard		anticorrosion			inch mm	tolerance inch/ μ m		inch mm	tolerance inch/ μ m	
steel retainer	resin retainer	stainless retainer	resin retainer			precision	high			
–	–	–	SWS 2	SWS 2G	4	.1250 3.175	0 –.00035	.3125 7.938	0 –.00040	
–	–	–	SWS 3	SWS 3G	4	.1875 4.763	0 – 8	.3750 9.525	0 – 9	
SW 4	SW 4G	SW 4GR	SWS 4	SWS 4G	4	.2500 6.350	0 –.00025	.5000 12.700	0 –.00045 –11	
SW 6	SW 6G	SW 6GR	SWS 6	SWS 6G	4	.3750 9.525	0 –.00025	.6250 15.875	0 –.00050	
SW 8	SW 8G	SW 8GR	SWS 8	SWS 8G	4	.5000 12.700	0 – 6	.8750 22.225	0 – 9	
SW10	SW10G	SW10GR	SWS10	SWS10G	4	.625 15.875	0 – 6	1.1250 28.575	0 – 13	
SW12	SW12G	SW12GR	SWS12	SWS12G	5	.7500 19.050	0 –.00030	1.2500 31.750	0 –.00040 –.00065	
SW16	SW16G	SW16GR	SWS16	SWS16G	6	1.0000 25.400	0 – 7	1.5625 39.688	0 – 10 –16	
SW20	SW20G	SW20GR	SWS20	SWS20G	6	1.2500 31.750	0 –.00035	2.0000 50.800	0 –.00050 –.00075	
SW24	SW24G	SW24GR	SWS24	SWS24G	6	1.5000 38.100	0 – 8	2.3750 60.325	0 – 12 –19	
SW32	SW32G	SW32GR	SWS32	SWS32G	6	2.0000 50.800	0 – 8	3.0000 76.200	0 – 12 –19	
SW40	–	–	–	–	6	2.5000 63.500	0 –.00040	3.7500 95.250	0 –.00060 –.00090	
SW48	–	–	–	–	6	3.0000 76.200	0 – 9	4.5000 114.300	0 – 15 –22	
SW64	–	–	–	–	6	4.0000 101.600	0 –.00040 –10	6.0000 152.400	0 –.00080 –20 –25	

SLIDE BUSH

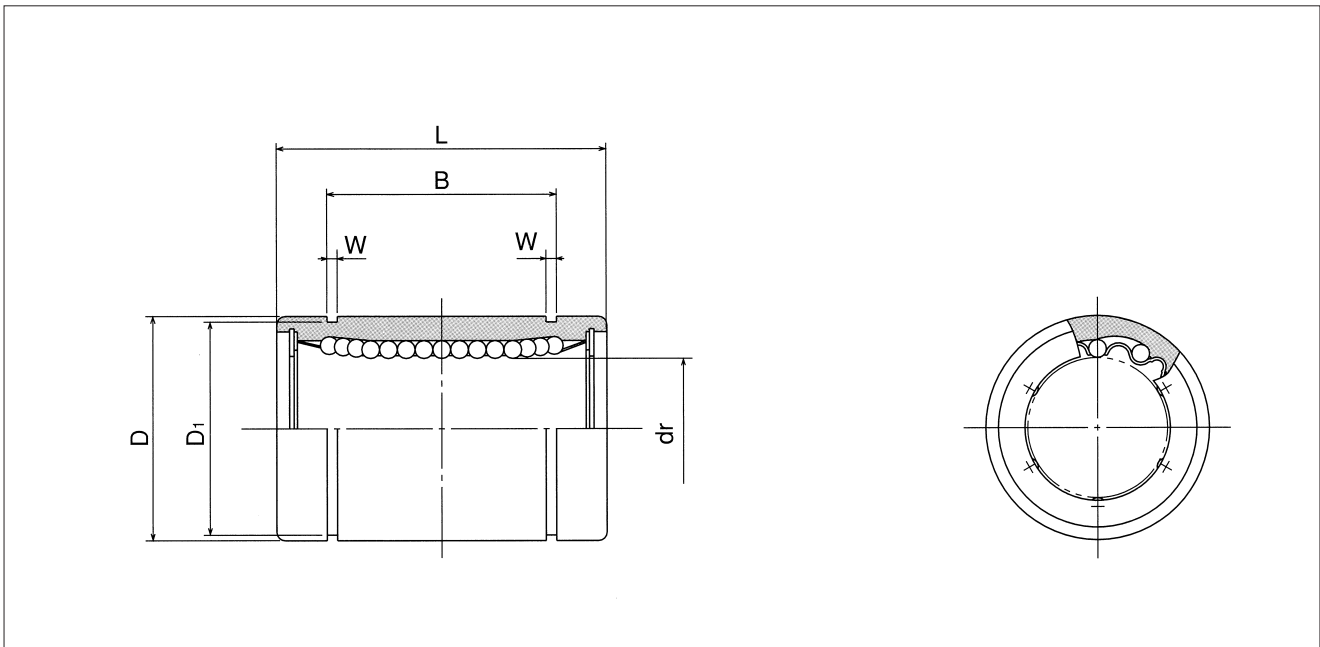

major dimensions						eccentricity		radial clearance (maximum) inch/ μ m	basic load rating		mass g	shaft diameter inch mm
inch mm	L tolerance inch/mm	inch mm	B tolerance inch/mm	inch mm	D ₁ inch mm	precision inch/ μ m	high inch/ μ m		C N	Co N		
.5000 12.700	0 - .008	.3681 9.35	0 - .008	.0280 0.710	.2902 7.370	-	.0003 8	- .0001 - 2	59	76	2.8	1/8 3.175
.5625 14.275		.4311 10.95		.0280 0.710	.3520 8.940				91	110	3.6	3/16 4.763
.7500 19.050		.5110 12.98		.0390 0.992	.4687 11.906				206	265	9.5	1/4 6.350
.8750 22.225		.6358 16.15		.0390 0.992	.5880 14.935				225	314	15	3/8 9.525
1.2500 31.750		.9625 24.46		.0459 1.168	.8209 20.853				510	784	42	1/2 12.700
1.5000 38.100		1.1039 28.04		.0559 1.422	1.0590 26.899				774	1,180	85	5/8 15.875
1.6250 41.275		1.1657 29.61		.0559 1.422	1.1760 29.870				862	1,370	104	3/4 19.050
2.2500 57.150	0 - .012	1.7547 44.57	0 - .012	.0679 1.727	1.4687 37.306	10	15	- 6	980	1,570	220	1 25.400
2.6250 66.675		2.0047 50.92		.0679 1.727	1.8859 47.904				1,570	2,740	465	1-1/4 31.750
3.0000 76.200		2.4118 61.26		0.859 2.184	2.2389 56.870				2,180	4,020	720	1-1/2 38.100
4.0000 101.600	0 - 0.3	3.1917 81.07	0 - 0.3	.1029 2.616	2.8379 72.085	.0007	.0010 25	- .0005 - 13	3,820	7,940	1,310	2 50.800
5.0000 127.000		3.9760 100.99		.1200 3.048	3.5519 90.220				4,700	10,000	2,600	2-1/2 63.500
6.0000 152.400	0 - .016	4.726 120.04	0 - .016	.1200 3.048	4.3100 109.474	.0008	.0012 30	- 20	7,350	16,000	4,380	3 76.200
8.0000 203.200	0 - 0.4	6.258 158.95	0 - 0.4	.1389 3.530	5.745 145.923				14,100	34,800	10,200	4 101.600

1N \approx 0.225lbf 1kg \approx 2.205lbs

SW-AJ TYPE

– Clearance Adjustable Type –

This type is an inch dimension series mainly used in the U.S.

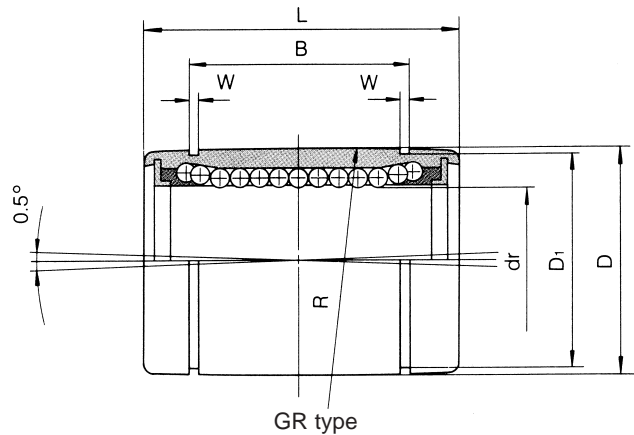
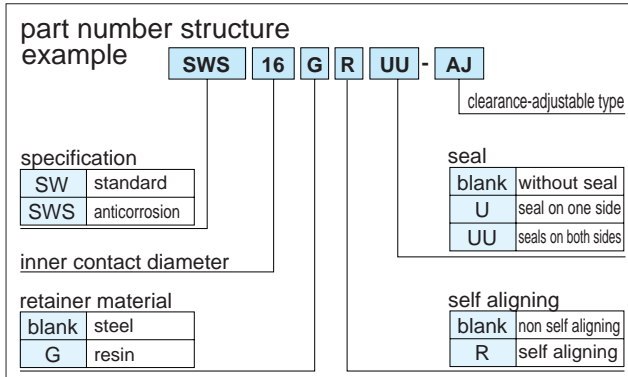

part number					number of ball circuits	D			
standard		anticorrosion		dr		D			
steel retainer	resin retainer	stainless retainer	resin retainer	inch mm		tolerance* inch/ μ m	inch mm	tolerance* inch/ μ m	
—	SW 4G-AJ	—	—	SWS 4G-AJ	4	.2500 6.350	—	.5000 12.700	$^{0}_{-11}$ $^{-0.00045}_{0}$
—	SW 6G-AJ	—	—	SWS 6G-AJ	4	.3750 9.525		$^{0}_{-9}$.6250 15.875
SW 8-AJ	SW 8G-AJ	SW 8GR-AJ	SWS 8-AJ	SWS 8G-AJ	4	5.000 12.700	$^{0}_{-9}$.8750 22.225	$^{-0.00050}_{0}$
SW10-AJ	SW10G-AJ	SW10GR-AJ	SWS10-AJ	SWS10G-AJ	4	.625 15.875	—	1.1250 28.575	$^{-13}_{0}$
SW12-AJ	SW12G-AJ	SW12GR-AJ	SWS12-AJ	SWS12G-AJ	5	.7500 19.050		$^{0}_{-10}$	1.2500 31.750
SW16-AJ	SW16G-AJ	SW16GR-AJ	SWS16-AJ	SWS16G-AJ	6	1.0000 25.400	$^{0}_{-10}$	1.5625 39.688	$^{0}_{-16}$
SW20-AJ	SW20G-AJ	SW20GR-AJ	SWS20-AJ	SWS20G-AJ	6	1.2500 31.750	$^{0}_{-12}$	2.0000 50.800	$^{0}_{-19}$ $^{-0.00075}_{0}$
SW24-AJ	SW24G-AJ	SW24GR-AJ	SWS24-AJ	SWS24G-AJ	6	1.5000 38.100	$^{0}_{-12}$	2.3750 60.325	$^{0}_{-19}$
SW32-AJ	SW32G-AJ	SW32GR-AJ	SWS32-AJ	SWS32G-AJ	6	2.0000 50.800	$^{0}_{-12}$	3.0000 76.200	$^{0}_{-19}$
SW40-AJ	—	—	—	—	6	2.5000 63.500	$^{0}_{-15}$	3.7500 95.250	$^{-0.00090}_{0}$
SW48-AJ	—	—	—	—	6	3.0000 76.200	$^{0}_{-15}$	4.5000 114.300	$^{-22}_{0}$
SW64-AJ	—	—	—	—	6	4.0000 101.600	$^{0}_{-20}$ $^{-0.00080}_{-20}$	6.0000 152.400	$^{0}_{-25}$ $^{-0.00100}_{-25}$

* Accuracy is measured prior to machining clearance slot.

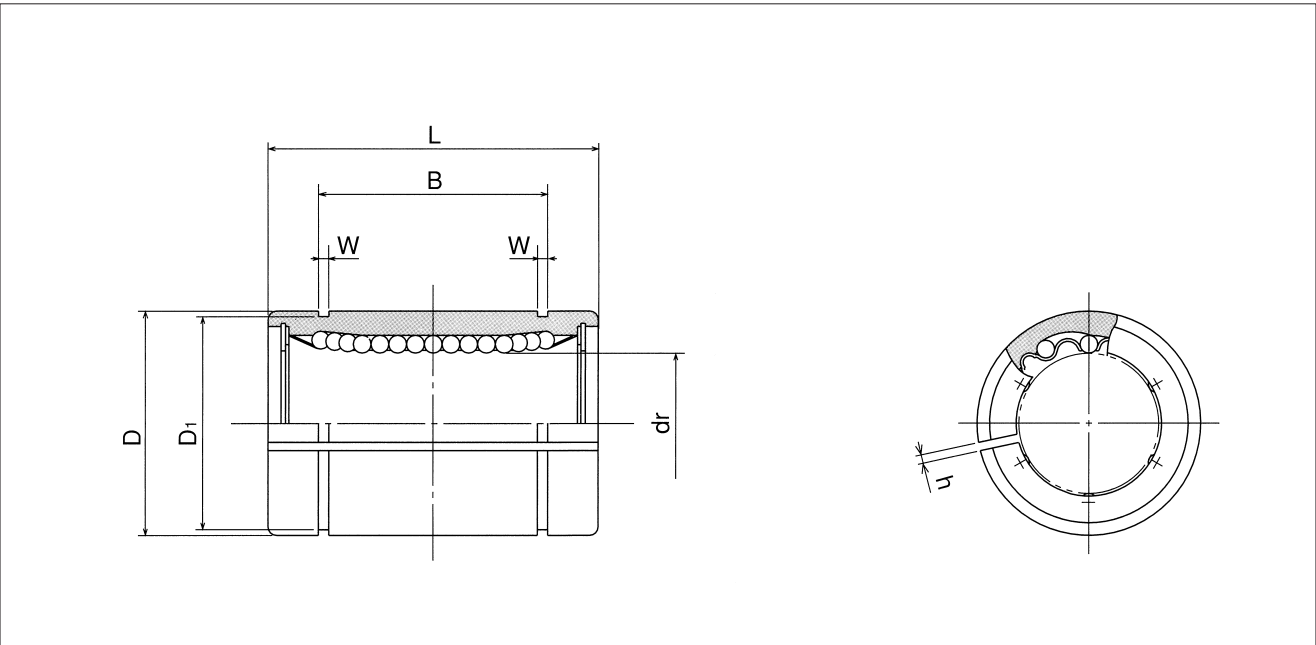

major dimensions							eccentricity	Radial clearance (Max)	basic load rating		mass	shaft diameter
inch	L tolerance	inch	B tolerance	W	D ₁	h			dynamic C	static Co		
mm	inch/mm	mm	inch/mm	mm	mm	mm	μm	inch/μm	N	N	g	mm
.7500 19.050	0	.5100 12.98	0	.0390 0.992	.4687 11.906	.04 1	.0005	-.0001	206	265	7.5	1/4 6.350
.8750 22.225		.6358 12.15		.0390 0.992	.5880 14.935	.04 1	12	-3	225	314	13.5	3/8 9.525
1.2500 31.750	-0.008	.9625 24.46	-0.008	.0459 1.168	.8209 20.853	.06 1.5	.0005	-.0001	510	784	41	1/2 12.700
1.5000 38.100		1.1039 28.04		.0559 1.422	1.0590 26.899	.06 1.5	12	-4	774	1,180	83	5/8 15.875
1.6250 41.275	-0.2	1.1657 29.61	-0.2	.0559 1.422	1.1760 29.870	.06 1.5	.0006	-.0002	862	1,370	102	3/4 19.050
2.2500 57.150		1.7547 44.57		.0679 1.727	1.4687 37.306	.06 1.5	15	-6	980	1,570	218	1 25.400
2.6250 66.675	0	2.0047 50.92	0	.0679 1.727	1.8859 47.904	.10 2.5	.0008	-.0003	1,570	2,740	455	1-1/4 31.750
3.0000 76.200		2.4118 61.26		.0859 2.184	2.2389 56.870	.12 3	20	-8	2,180	4,020	710	1-1/2 38.100
4.0000 101.600	-0.3	3.1917 81.07	-0.3	.1029 2.616	2.8379 72.085	.12 3	.0010	-.0005	3,820	7,940	1,290	2 50.800
5.0000 127.000		3.9760 100.99		.1200 3.048	3.5519 90.220	.12 3		25	-13	4,700	10,000	2,560
6.0000 152.400	0	4.726 120.04	0	.1200 3.048	4.3100 109.474	.12 3	.0012	-.0008	7,350	16,000	4,350	3 76.200
8.0000 203.200		6.258 158.95		.1389 3.530	5.745 145.923	.12 3		30	-20	14,100	34,800	10,150

1N ≅ 0.225lbf 1kg ≅ 2.205lbs

SW-OP TYPE

— Open Type —

This type is an inch dimension series mainly used in the U.S.

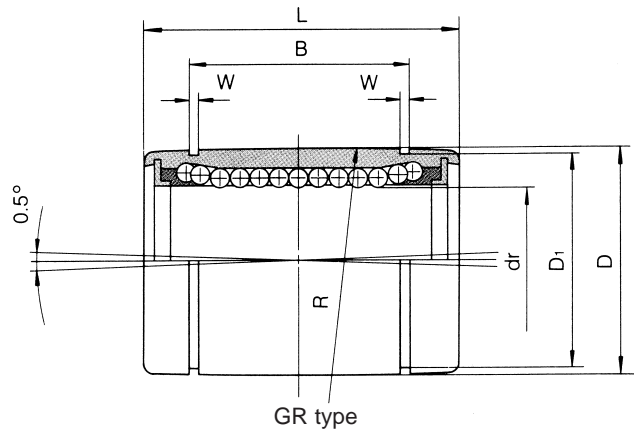
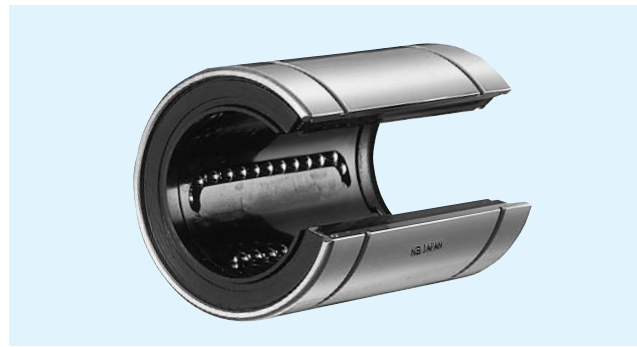
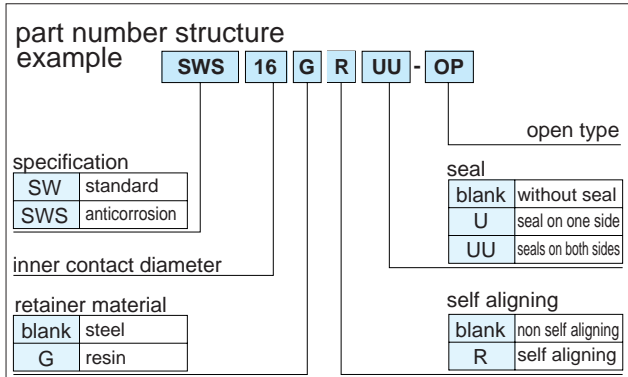

part number					number of ball circuits	dr		D	
standard		anticorrosion		inch		tolerance	inch	tolerance	
steel retainer	resin retainer	stainless retainer	resin retainer	mm		inch/ μ m	mm	inch/ μ m	
SW 8-OP	SW 8G-OP	SW 8GR-OP	SWS 8-OP	SWS 8G-OP	3	.5000 12.700	0 -.00040	.8750 22.225	0 -.00050
SW10-OP	SW10G-OP	SW10GR-OP	SWS10-OP	SWS10G-OP	3	.625 15.875	0 - 9	1.1250 28.575	0 - 13
SW12-OP	SW12G-OP	SW12GR-OP	SWS12-OP	SWS12G-OP	4	.7500 19.050	0 -.00040	1.2500 31.750	0 -.00065
SW16-OP	SW16G-OP	SW16GR-OP	SWS16-OP	SWS16G-OP	5	1.0000 25.400	0 -10	1.5625 39.688	0 - 16
SW20-OP	SW20G-OP	SW20GR-OP	SWS20-OP	SWS20G-OP	5	1.2500 31.750	0 -.00050	2.0000 50.800	0 -.00075
SW24-OP	SW24G-OP	SW24GR-OP	SWS24-OP	SWS24G-OP	5	1.5000 38.100	0 -12	2.3750 60.325	0 - 19
SW32-OP	SW32G-OP	SW32GR-OP	SWS32-OP	SWS32G-OP	5	2.0000 50.800	0 -15	3.0000 76.200	0 - 22
SW40-OP	-	-	-	-	5	2.5000 63.500	0 -.00060	3.7500 95.250	0 - 22
SW48-OP	-	-	-	-	5	3.0000 76.200	0 -15	4.50000 114.300	0 - 22
SW64-OP	-	-	-	-	5	4.0000 101.600	0 -.00080 -20	6.0000 152.400	0 -.00100 -25

* Accuracy is measured prior to machining open slot.

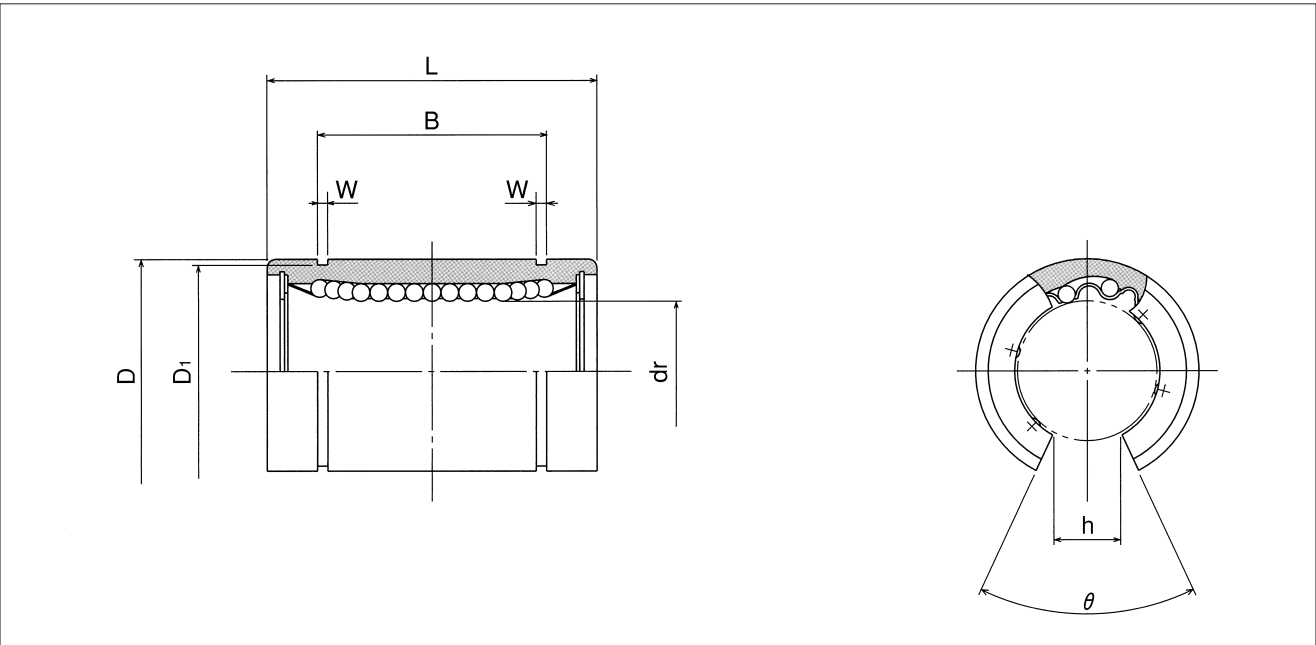

major dimensions								eccentricity* inch μm	Radial clearance (Max) inch/μm	basic load rating		mass g	shaft diameter inch mm
L		B		W	D ₁	h	θ			dynamic C N	static C ₀ N		
inch mm	tolerance inch/mm	inch mm	tolerance inch/mm	inch mm	inch mm	inch mm	°						
1.2500 31.750	0	.9625 24.46	0	.0459 1.168	.8209 20.853	.34 7.9375	80°	.0005 12	-.0001 -4	510	784	32	1/2 12.700
1.5000 38.100	-.008	1.1039 28.04	-.008	.0559 1.422	1.0590 26.899	.375 9.5250	80°			774	1,180	64	5/8 15.875
1.6250 41.275	0	1.1657 29.61	0	.0559 1.422	1.1760 29.870	.4375 11.1125	60°	.0006 15	-.0002 -6	862	1,370	86	3/4 19.050
2.2500 57.150	-.012	1.7547 44.57	-.012	.0679 1.727	1.4687 37.306	.5625 14.2875	50°			980	1,570	190	1 25.400
2.6250 66.675	0	2.0047 50.92	0	.0679 1.727	1.8859 47.904	.625 15.875	50°	.0008 20	-.0003 -8	1,570	2,740	390	1-1/4 31.750
3.0000 76.200	0	2.4118 61.26	0	0.859 2.184	2.2389 56.870	.75 19.05	50°			2,180	4,020	610	1-1/2 38.100
4.0000 101.600	-.03	3.1917 81.07	-.03	.1029 2.616	2.8379 72.085	1.0 25.40	50°			3,820	7,940	1,120	2 50.800
5.0000 127.000	0	3.9760 100.99	0	.1200 3.048	3.5519 90.220	1.25 31.75	50°	.0010 25	-.0005 -13	4,700	10,000	2,230	2-1/2 63.500
6.0000 152.400	-.016	4.726 120.04	-.016	.1200 3.048	4.3100 109.474	1.5 38.10	50°			7,350	16,000	3,750	3 76.200
8.0000 203.200	0 -.04	6.258 158.95	0 -.04	.1389 3.530	5.745 145.923	2.0 50.8	50°	.0012 30	-.0008 -20	14,100	34,800	8,740	4 101.60

1N ≅ 0.225lbf 1kg ≅ 2.205lbs

SW-W TYPE

— Double-Wide Type —

This type is an inch dimension series mainly used in the U.S.

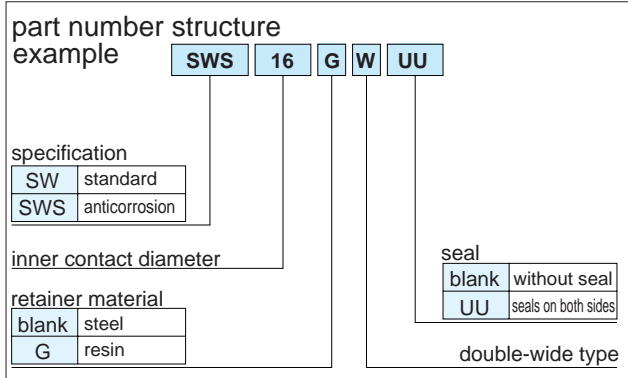

part number				number of ball circuits	dr			
standard		anticorrosion			inch mm	tolerance inch/ μ m	D	
steel retainer	resin retainer	stainless retainer	resin retainer				inch mm	tolerance inch/ μ m
SW 4W	SW 4GW	SWS 4W	SWS 4GW	4	.2500 6.350	- .00040 0 -10	.5000 12.700	- .00050 0 -13
SW 6W	SW 6GW	SWS 6W	SWS 6GW	4	.3750 9.525		.6250 15.875	- .00065 0 -16
SW 8W	SW 8GW	SWS 8W	SWS 8GW	4	.5000 12.700		.8750 22.225	
SW10W	SW10GW	SWS10W	SWS10GW	4	.6250 15.875		1.1250 28.575	
SW12W	SW12GW	SWS12W	SWS12GW	5	.7500 19.050	- .00050 0	1.2500 31.750	- .00075 0
SW16W	SW16GW	SWS16W	SWS16GW	6	1.0000 25.400	-12 0	1.5625 39.688	-19 0
SW20W	SW20GW	SWS20W	SWS20GW	6	1.2500 31.750	- .00060 0 -15	2.0000 50.800	- .00090 0
SW24W	SW24GW	SWS24W	SWS24GW	6	1.5000 38.100		2.3750 60.325	-22 0
SW32W	SW32GW	SWS32W	SWS32GW	6	2.0000 50.800		3.0000 76.200	- .00100 0 -25

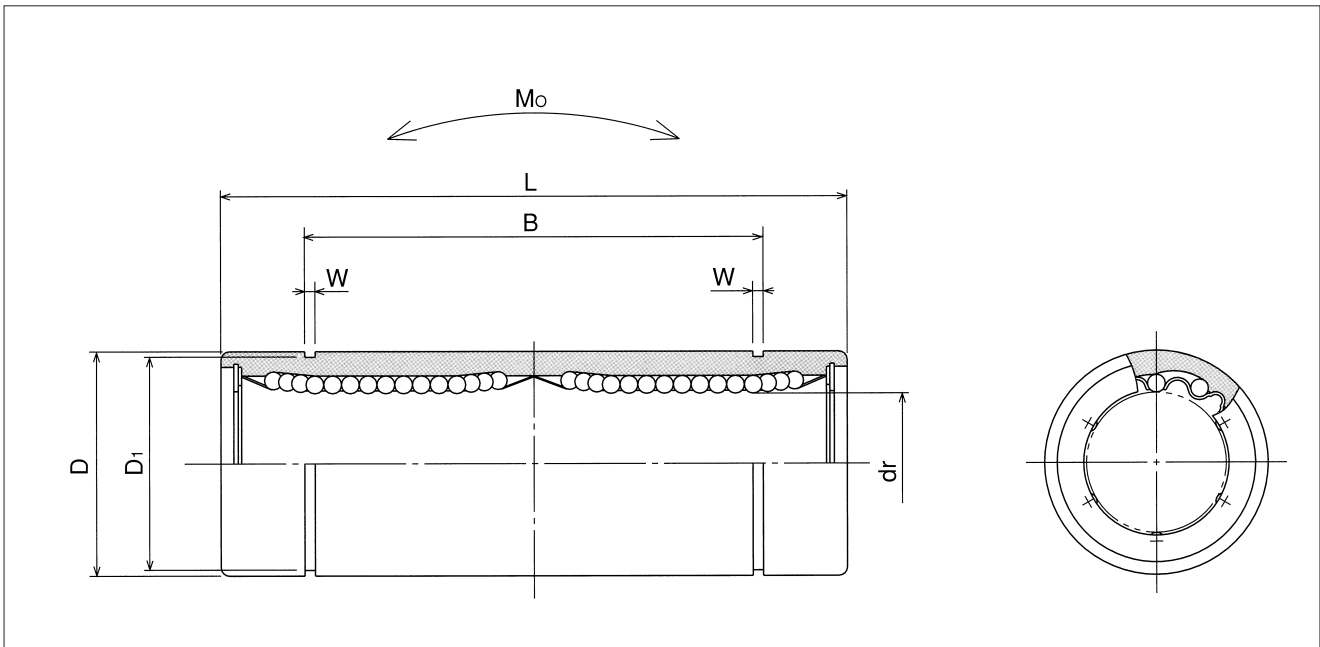

major dimensions						eccentricity	basic load rating		allowable static moment	mass	shaft diameter			
inch	L	B		W	D_1		dynamic	static						
mm	tolerance	inch	tolerance	inch	inch	C	C_o	M_o	g	inch				
	inch/mm	mm	inch/mm	mm	mm	N	N	N · m		mm				
1.3750 34.925	0 - .012	1.0220 25.959	0 - .012	.0390 0.992	.4687 11.906	.0006	323	530	2.0	17.5	1/4 6.350			
1.5938 40.481		1.2716 32.298		.0390 0.992	.5880 14.935		353	630				2.7	28	3/8 9.525
2.3750 60.325		1.9250 48.895		.0459 1.168	.8209 20.853		813	1,570				11.5	80	1/2 12.700
2.8125 71.438	0 -0.3	2.2079 56.080	0 -0.3	.0559 1.422	1.0590 26.899	.0008	1,230	2,350	20.0	160	5/8 15.875			
3.0937 78.581	2.3314 59.218	.0559 1.422	1.1760 29.870	1,370	2,740		26.5	195				3/4 19.050		
4.2813 108.744	0 - .016	3.5094 89.139	0 - .016	.0679 1.727	1.4687 37.306	20	1,570	3,140	41.2	410	1 25.400			
5.0000 127.000		4.0094 101.839		.0679 1.727	1.8859 47.904		2,500	5,490				84.8	820	1-1/4 31.750
5.6875 144.463		4.8236 122.519		.0859 2.184	2.2389 56.870		3,430	8,040				143	1,250	1-1/2 38.100
7.7500 196.850	0 -0.4	6.3834 162.138	0 -0.4	.1029 2.616	2.8379 72.085	.0012 30	6,080	15,900	399	2,350	2 50.800			

1N ≅ 0.225lbf 1N·m ≅ 0.738lb·ft