

# BALL SPLINE ROTARY BALL SPLINE STROKE BALL SPLINE

SLIDE GUIDE

BALL SPLINE  
ROTARY BALL SPLINE  
STROKE BALL SPLINE

TOPBALL® PRODUCTS

SLIDE BUSH

SLIDE UNIT

STROKE BUSH  
SLIDE ROTARY BUSH

SLIDE SHAFT

SLIDE WAY/GONIO WAY  
SLIDE TABLE  
MINIATURE SLIDE

ACTUATOR

SLIDE SCREW

# BALL SPLINE

The NB ball spline is a linear motion mechanism utilizing the rotational motion of ball elements. It can be used in a wide variety of applications including robotics and transport type equipment.

## STRUCTURE AND ADVANTAGES

The NB ball spline consists of a spline shaft with raceway grooves and a spline nut. The spline nut consists of an outer cylinder (main body), retainer, side rings, and ball elements. Designed and manufactured to achieve a reliably smooth motion.

### High Load Capacity and Long Travel Life:

The raceway grooves are machined to a radius close to that of the ball elements. The large ball contact area results in high load capacity and long travel life.

### Wide Variety of Configurations:

16 shaft sizes with diameters from 4mm to 100mm are available. Seven different types of nuts are available: cylindrical types (SSP/SSPM), flange types (SSPF/SSPT), and block types (SPA/SPA-W/SSPB). Material option of Stainless steel(440C or equivalent) is also available. They can be specified to suit various applications.

### Transmission of Torque:

NB ball splines can sustain loads in several directions simultaneously. They can be used as a single shaft system and can transmit (or resist) torque.

### Ease of Additional Custom Machining:

Since a round shaft with raceway grooves is used, NB ball spline shafts can be machined easily to customized specifications.

### High-Speed Motion and High-Speed Rotation:

The outer cylinder is compact and well balanced, resulting in good performance at high speed.

Figure B-1 Basic Structure of NB Ball Spline

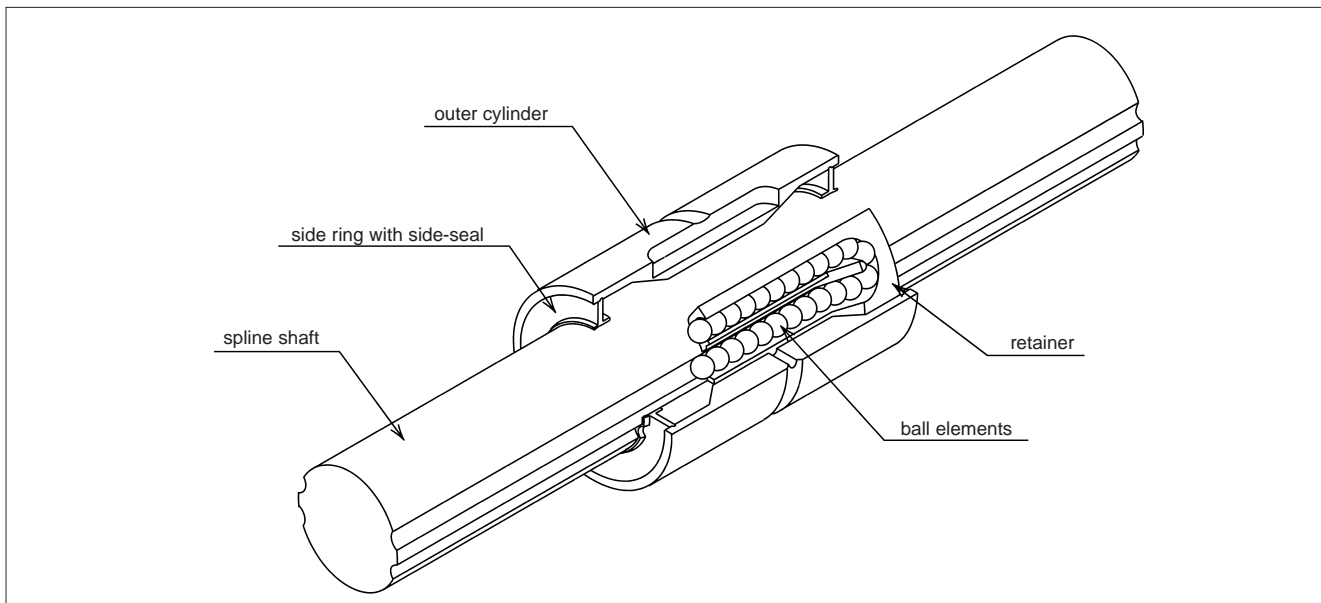

## TYPE

### TYPES OF SPLINE NUT:

A wide variety of spline nut designs are available and all spline nuts come with a side-seal as a standard feature.

Table B-1 Types of Spline Nut

type of nut		shape and advantage		page number for dimension table
cylindrical type	SSP SSPS		<ul style="list-style-type: none"> <li>cylindrical spline nut with key groove</li> <li>with special key</li> <li>nominal diameter: SSP4-100 : SSPS4-25</li> </ul>	P.B-16
	SSPM		<ul style="list-style-type: none"> <li>cylindrical spline nut without key groove</li> <li>with two lock plates for fixing</li> <li>nominal diameter: 6mm-10mm</li> </ul>	P.B-18
flange type	SSPF SSPFS		<ul style="list-style-type: none"> <li>spline nut with flange</li> <li>nominal diameter: SSPF6-60 : SSPFS6-25</li> </ul>	P.B-20
	SSPT		<ul style="list-style-type: none"> <li>spline nut with a two side cut flange</li> <li>nominal diameter: 6mm-10mm</li> </ul>	P.B-22



Table B-2 Types of Spline Nut

type of nut		shape and advantage		page number for dimension table
block type	SPA		<ul style="list-style-type: none"> <li>• aluminum housing</li> <li>• lightweight and compact</li> <li>• with keyless spline</li> <li>• nominal diameter: 6mm-10mm</li> </ul>	P.B-24
	SPA-W		<ul style="list-style-type: none"> <li>• aluminum housing</li> <li>• can sustain high moment loading</li> <li>• with two keyless splines</li> <li>• with grease fitting</li> <li>• nominal diameter: 6mm-10mm</li> </ul>	P.B-26
	SSPB		<ul style="list-style-type: none"> <li>• cast block</li> <li>• spline grooves are machined directly on main body</li> <li>• high rigidity</li> <li>• with grease fitting</li> <li>• nominal diameter: 20mm-40mm</li> </ul>	P.B-28

## TYPES OF SPLINE SHAFT:

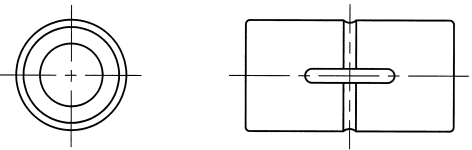
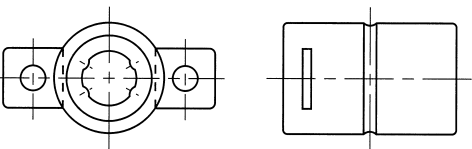
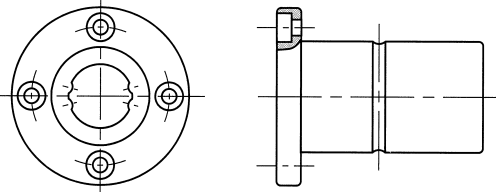
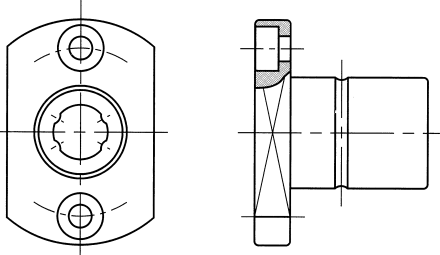
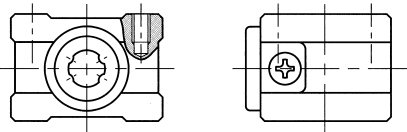
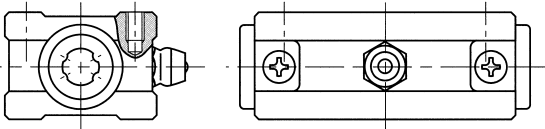
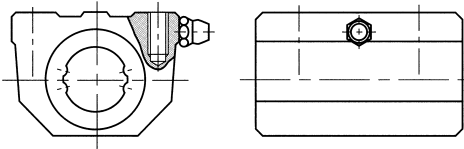
Depending on the application requirements, either a fully machine ground spline shaft or a commercial grade spline shaft can be specified.

Table B-3 Types of Spline Shaft

type of spline shaft	shape and advantage
ground spline shaft	 <ul style="list-style-type: none"> <li>• precision-ground and precision machined surface finish</li> <li>• high precision</li> <li>• possible to machine ends of spline shaft and surface finish</li> <li>• nominal diameter: 4mm-100mm</li> </ul>
standard spline shaft	 <ul style="list-style-type: none"> <li>• standard dimension and shape</li> <li>• accuracy grade: high grade</li> <li>• short lead time</li> <li>• nominal diameter: 4mm-60mm (Refer to page B-30)</li> </ul>
commercial shaft (non-ground)	 <ul style="list-style-type: none"> <li>• for general industrial use</li> <li>• with special finished raceway surface</li> <li>• low cost</li> <li>• possible to machine ends of spline shaft and surface finish</li> <li>• nominal diameter: 20mm-50mm</li> <li>• maximum length: 5000mm (Refer to page B-31)</li> </ul>

## ACCURACY

The NB ball spline is measured for accuracy at points shown in Figure B-2 and categorized as either high-grade or precision-grade (P). Contact NB for accuracy information on the commercial type ball spline.

Table B-4 Tolerance of Spline Shaft and groove torsion

type of shaft	ground shaft	
	high	precision (P)
tolerance	13 $\mu$ m/100mm	6 $\mu$ m/100mm

Figure B-2 Accuracy Measurement Points

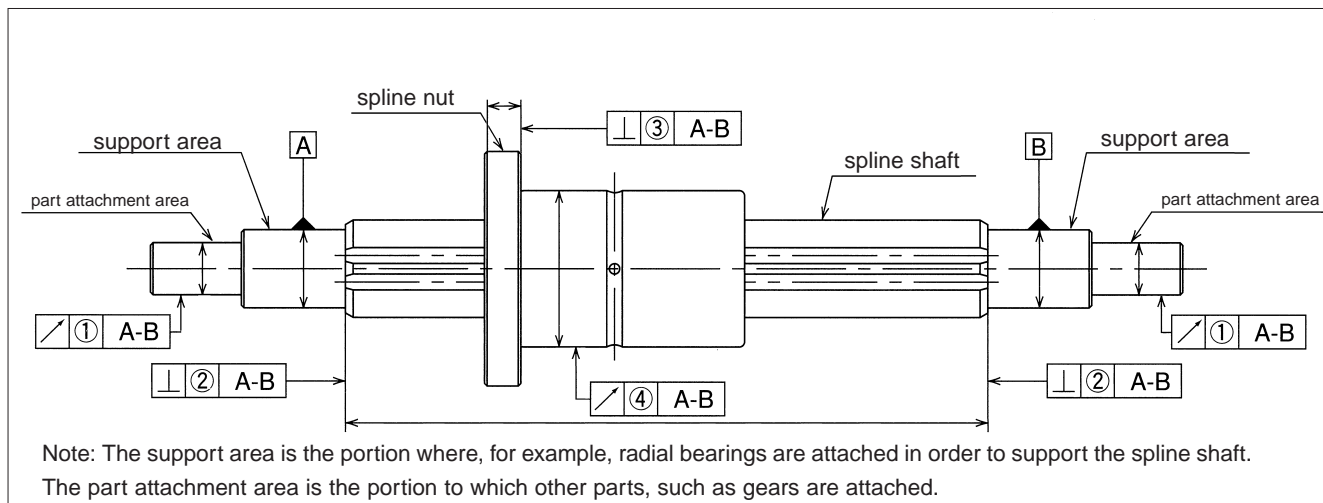

Table B-5 Tolerance of Parts Relative to Spline Support Area (Max.)

unit/ $\mu$ m

part number	radial run-out of part attachment area ①		perpendicularity of the end of the spline shaft section ②		perpendicularity of the flange ③	
	high-grade	precision-grade	high-grade	precision-grade	high-grade	precision-grade
SSP 4	14	8	9	6	—	—
SSP 6					11	8
SSP 8					13	9
SSP 10	17	10				
SSP 13A						
SSP 16A						
SSP 20A	19	12	11	8		
SSP 20						
SSP 25A	22	13	13	9	16	11
SSP 25						
SSP 30						
SSP 40	25	15	16	11	19	13
SSP 50						
SSP 60	29	17	19	13	22	15
SSP 80 · 80L						
SSP100 · 100L	34	20	22	15	—	—

Table B-6 ④Radial Run-Out of Outer Surface of Spline Nut Relative to Spline Shaft Support Area (Max.)

 unit/ $\mu\text{m}$ 

total length of spline shaft (mm)		part number															
		SSP4 SSP6 SSP8		SSP10		SSP13A SSP16A		SSP20A SSP25A		SSP20 SSP25 SSP30		SSP40 SSP50		SSP60 SSP80 SSP80L		SSP100 SSP100L	
greater than	or less	high-grade	precision grade	high-grade	precision grade	high-grade	precision grade	high-grade	precision grade	high-grade	precision grade	high-grade	precision grade	high-grade	precision grade	high-grade	precision grade
—	200	46	26	36	20	34	18	32	18	32	18	32	16	30	16	30	16
200	315	89	57	54	32	45	25	39	21	39	21	36	19	34	17	32	17
315	400	126*	82*	68	41	53	31	44	25	44	25	39	21	36	19	34	17
400	500	163*	108*	82	51	62	38	50	29	50	29	43	24	38	21	35	19
500	630	—	—	102	65	75	46	57	34	57	34	47	27	41	23	37	20
630	800	—	—	—	—	92	58	68	42	68	42	54	32	45	26	40	22
800	1,000	—	—	—	—	115	75	83	52	83	52	63	38	51	30	43	24
1,000	1,250	—	—	—	—	153	97	102	65	102	65	76	47	59	35	48	28
1,250	1,600	—	—	—	—	195*	127*	130	85	130	85	93	59	70	43	55	33
1,600	2,000	—	—	—	—	—	—	171	116	171	116	118	77	86	54	65	40

\*SSP4 maximum fabrication length: 300mm; SSP6 maximum fabrication length: 400mm; SSP13A, 16A maximum fabrication length: 1500mm

\*\*For lengths exceeding 2000mm, contact NB.

## PRE-LOAD AND CLEARANCE IN ROTATIONAL DIRECTION

Both the clearance and pre-load are expressed in terms of clearance in the rotational direction. The pre-load is categorized into three different levels : standard, light (T1), and medium (T2). A pre-load cannot be specified when using the commercial grade spline shaft.

 Table B-7 Pre-Load and Clearance in Rotational Direction unit/ $\mu\text{m}$ 

part number	standard	light (T1)	medium (T2)
SSP 4	-2~+1	-6~-2	—
SSP 6			
SSP 8			
SSP 10	-3~+1	-9~-3	-13~-7
SSP 13A			
SSP 16A			
SSP 20A	-4~+2	-12~-4	-20~-12
SSP 20			
SSP 25A			
SSP 25			
SSP 30	-6~+3	-18~-6	-30~-18
SSP 40			
SSP 50			
SSP 60			
SSP 80(L)	-8~+4	-24~-8	-40~-24
SSP100(L)			

Table B-8 Operating Condition and Pre-Load

pre-load	pre-load symbol	operating condition
standard	—	Minute vibration is applied. A precise motion is required. A torque in a given direction is applied.
light	T1	Slight vibration is applied. Slight torsional load is applied. Cyclic torque is applied
medium	T2	Shock/vibration is applied. Over-hang load is applied. Torsional load is applied.

## LIFE CALCULATION

Because ball elements are used as the rolling elements in ball splines, the following equations are used to calculate the life of ball spline systems.

For radial load

$$L = \left( \frac{f_c}{f_w} \cdot \frac{C}{P} \right)^3 \cdot 50$$

For torsional load

$$L = \left( \frac{f_c}{f_w} \cdot \frac{C_T}{T} \right)^3 \cdot 50$$

L : travel life (km)

f<sub>c</sub> : contact coefficient

f<sub>w</sub> : Load coefficient

C : basic dynamic load rating(N)

P : load(N) C<sub>T</sub> : basic dynamic torque rating(N-m)

T : torque(N-m)

\* Refer to page Eng-5 for coefficients

\*\* The rated load for the commercial spline shaft is approximately 70% of the standard ball spline shaft.

## OPERATING ENVIRONMENT

The performance of a ball spline system is affected by the operating condition and environment of the application. The operating conditions should therefore be carefully taken into consideration.

### Dust Prevention:

The invasion of foreign particles and dust may affect the motion characteristics and shorten the life of a ball spline. Seals will perform well under normal operating conditions. However, they may not prevent the entry of foreign particles in a hostile environment. When used in such an environment, the ball spline should be protected using bellows and protective covers.

### Operating Temperature:

The ball retainers used in ball spline nuts are made of resin, so the operating temperature should never exceed 80°C.

Figure B-3 Radial Loading and Torque Loading

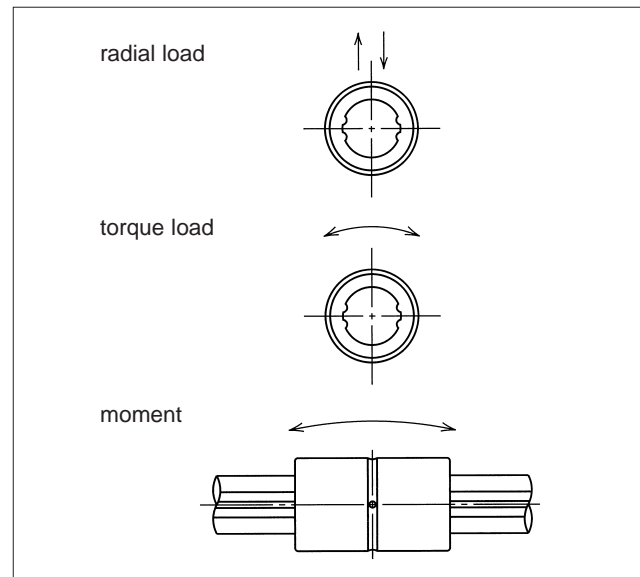
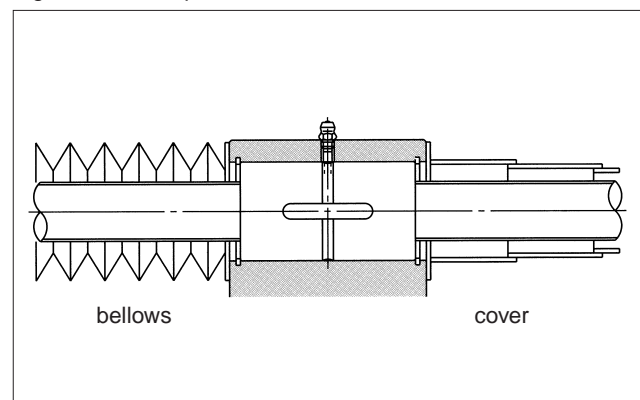

Figure B-4 Examples of Dust Prevention Methods



### Excessive Moment:

The allowable load for ball splines is high, and they can also sustain high moment load. However, when the load becomes excessive, the load applied to the raceway grooves becomes unbalanced and stable motion may not be achieved. When accuracy is required, the application of excessive moment should be prevented by using two or more spline nuts.

## LUBRICATION

Both ends of the spline nut have a side-seal as a standard feature. For the fully ground spline shaft, the side-seals are positioned against the spline shaft so as to prevent the lubricant from leaking out of the spline nut.

Lithium soap grease is applied to NB ball spline nuts before shipping, so there is no need to apply lubricant at the time of installation. However, a small amount of lubricant may be lost during operation, so the lubricant needs to be replenished periodically.

Figure B-5 Example of Lubrication Mechanism

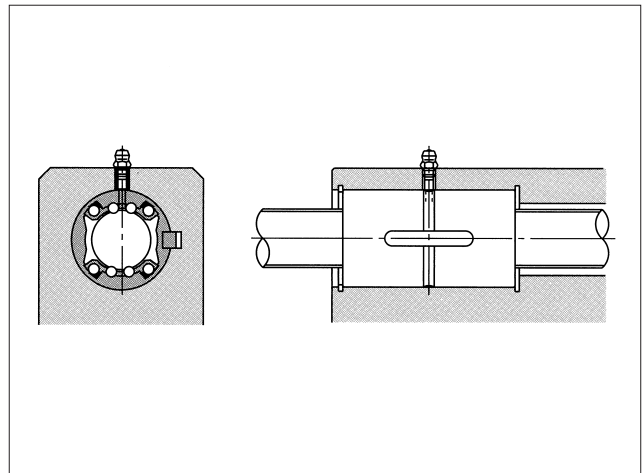

## SPECIAL REQUIREMENTS

NB will fabricate custom shafts, spline nut, surface finish, etc. to meet customer requirements.

For hollow spline shafts, recommended standard inner diameters are listed in Table B-9. Contact NB for details.

Figure B-6 Example of End-Machining

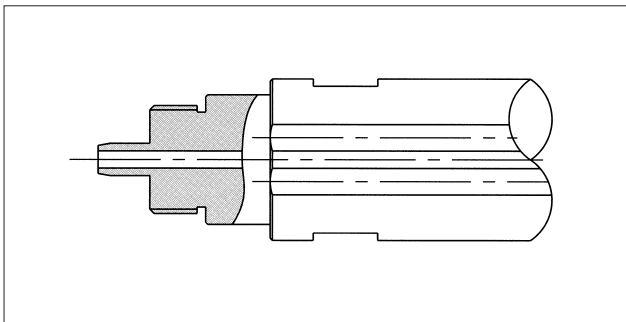
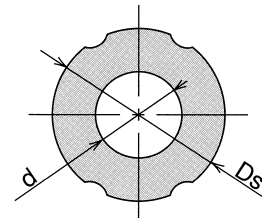

Table B-9 Recommended Inner Diameter for Hollow Spline Shaft

part number	shaft diameter	inner diameter	cross-sectional coefficient	second moment of inertia
	Ds mm	d mm	Z mm <sup>3</sup>	I mm <sup>4</sup>
SSP 4	4	1.5	5.7	11
SSP 6	6	2	19.4	58
SSP 8	8	3	46.5	186
SSP 10	10	4	89.6	448
SSP 13A	13	6	193	1,260
SSP 16A	16	8	348	2,780



## MOUNTING

### Fit:

A transition fit between an SSP/SSPM-type spline nut and its housing bore is used to minimize the clearance. If high accuracy is not required, then a clearance fit is used.

For the SSP/SSPM type spline nuts, if only a light load is to be applied, a hole slightly larger than the outer diameter of the nut will suffice.

### Insertion of Spline Nut:

When inserting a spline nut into the housing, use a jig, example as shown in Figure B-7. Carefully insert the nut so as not to hit the side ring and side-seal.

Table B-11 Recommended Jig Dimensions unit/mm

part number	D	d	part number	D	d
SSP 4	9.5	3.5	SSP 25	36.5	20.5
SSP 6	13.5	5	SSP 30	44.5	25
SSP 8	15.5	7	SSP 40	59.5	33
SSP10	20.5	8.5	SSP 50	74	41
SSP13A	23.5	12	SSP 60	89	50
SSP16A	30.5	14.5	SSP 80	119	74
SSP20A	34.5	18	SSP 80L		
SSP20	31.5	16.5	SSP100	149	92
SSP25A	41.5	22.5	SSP100L		

### Insertion of Spline Shaft:

Insertion of Spline Shaft: When inserting the spline shaft into the spline nut, ensure that the ball elements do not drop out. This is accomplished by aligning the raceway grooves of the shaft with the rows of ball elements in the nut. Then simply insert the spline shaft through the spline nut.

Table B-10 Fit for the Spline Nut

type of spline nut	clearance fit	transition fit
SSP	H7	J6
SSPM		

Figure B-7 Insertion of Spline Nute into Housing

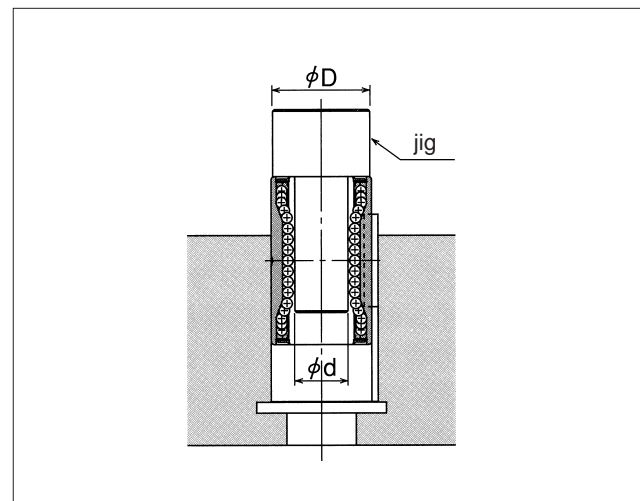

## Mounting of SSP Type Spline:

Example methods for installing the SSP type spline are shown in Figures B-8 and B-9.

Figure B-8 Using a Retaining Ring

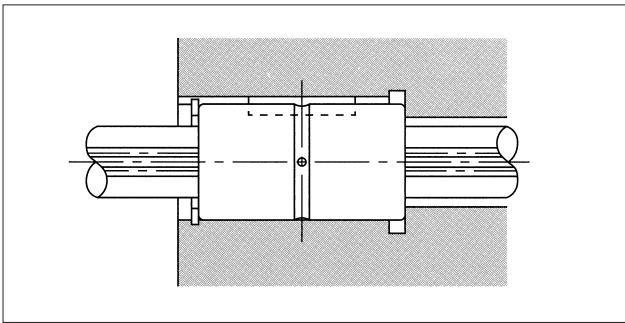
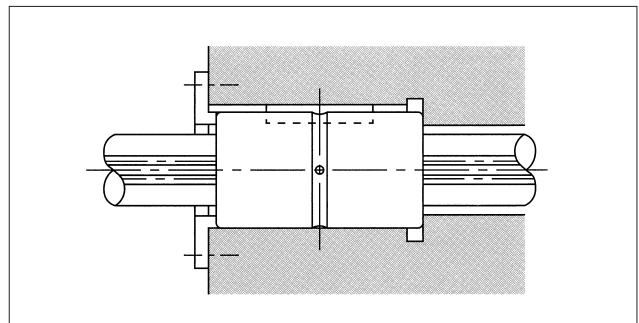

Figure B-9 Using a Push Plate



## Key:

The SSP type spline comes with a key, as shown in Figure B-10.

Figure B-10 Key for SSP Type Spline

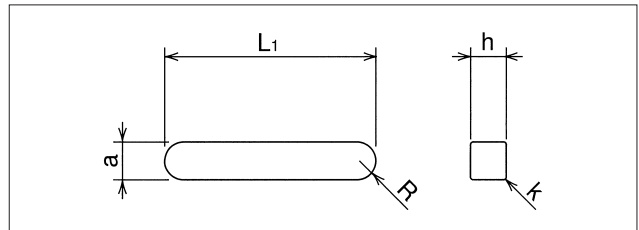

Table B-12 Major Dimensions of Key (SSP Type)

part number	a		h		L <sub>1</sub> mm	R mm	k mm		
	mm	tolerance μm	mm	tolerance μm					
SSP 4	2	+16 +6	2	0 -25	6	1	0.2		
SSP 6	2.5		2.5		10.5				
SSP 8	2.5		2.5		10.5				
SSP 10	3		3		13				
SSP 13A	3		3		15				
SSP 16A	3.5	+24 +12	3.5	0 -30	17.5	1.75	0.5 0.2 0.3		
SSP 20A	4		4		29				
SSP 20			4		26				
SSP 25A			4		36				
SSP 25	5		5		33			2.5	0.3
SSP 30	7		7		41			3.5	
SSP 40	10		8		55			5	
SSP 50	15	+36 +18	10	-36	60	7.5	0.5		
SSP 60	18		11		0/-43			68	9
SSP 80	16		10		0			76	
SSP 80L		10	-36	110	8				
SSP100	20	+43	0	110		10	0.8		
SSP100L		+22	-43	160					

**Mounting of SSPM Type Spline:**

Example methods for installing the SSPM spline are shown in Figures B-11 to B-14.

Figure B-11 Using an F Type Lock Plate

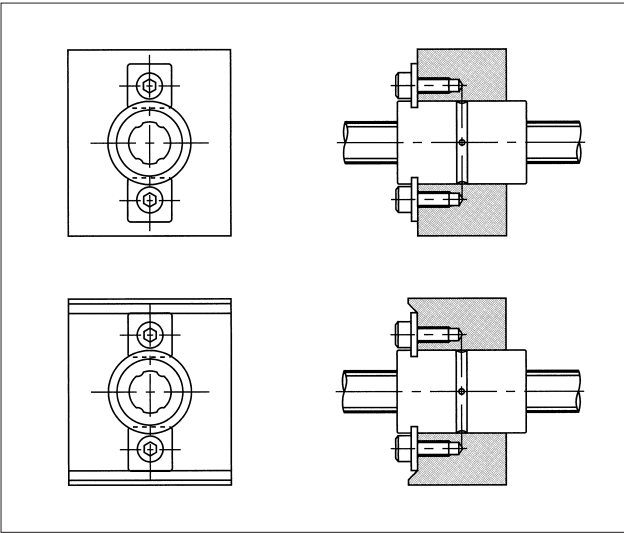

Figure B-12 Using an LP Type Lock Plate

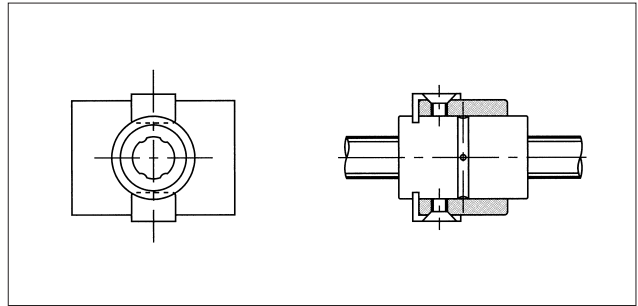

Figure B-13 Using a Special Lock Plate (1)

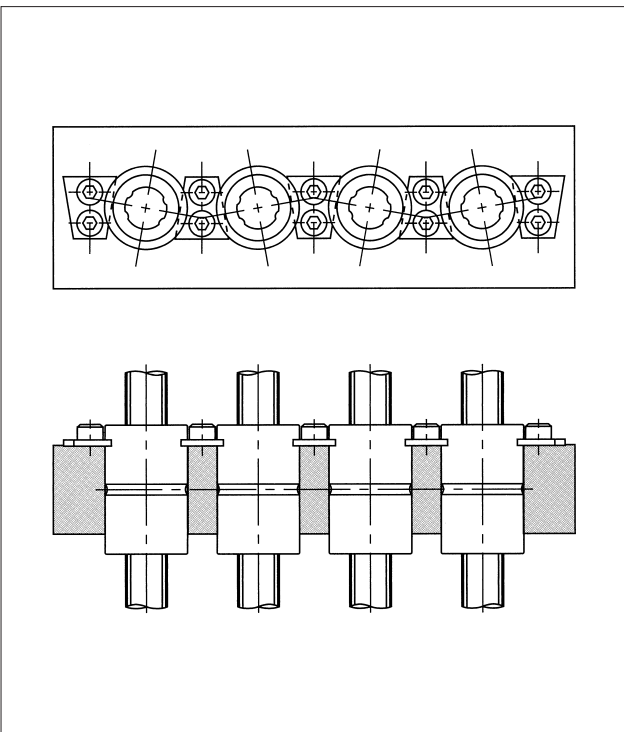
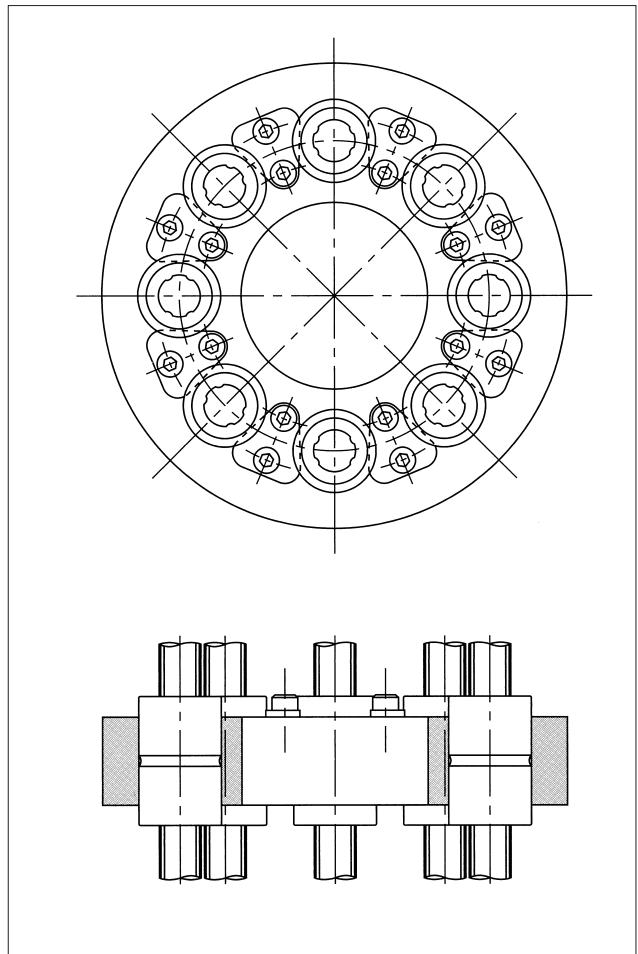

Figure B-14 Using a Special Lock Plate (2)





### Mounting of SSPF Type Spline:

Example methods for installing the SSPF spline are shown in Figure B-17.

Figure B-17 Example Methods for installing SSPF Type Spline

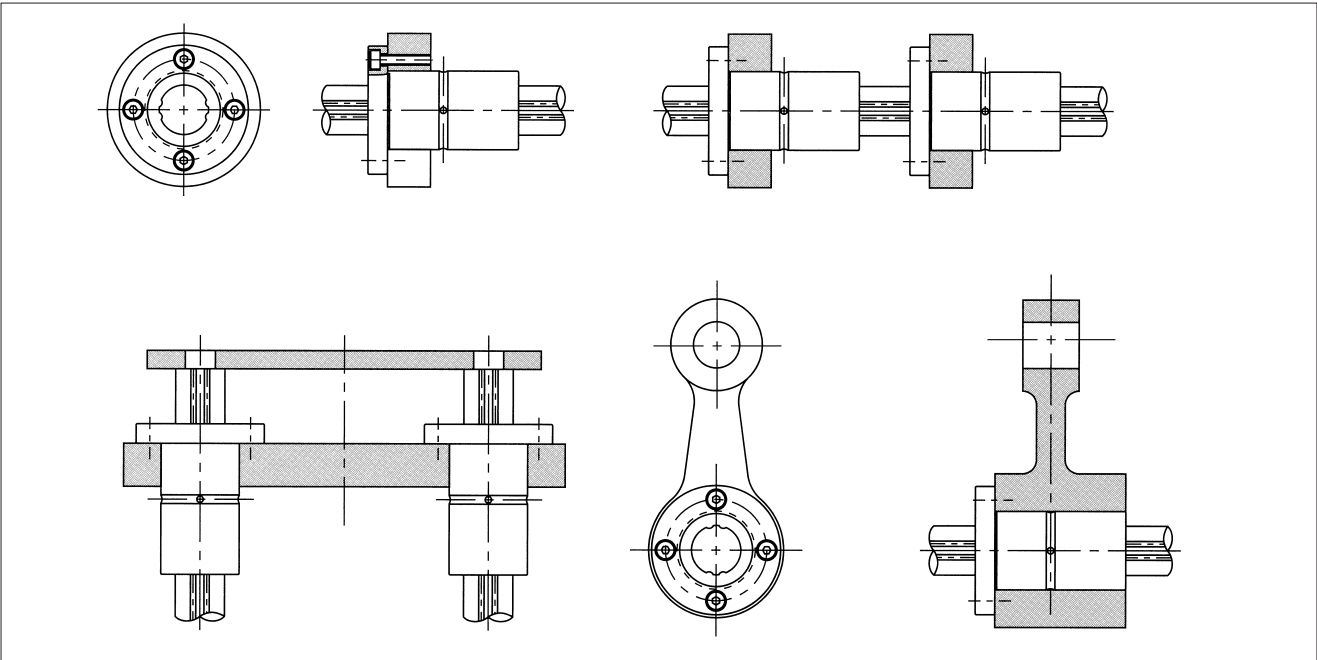

### Mounting of SSPT Spline:

Example methods for installing the SSPT spline are shown in Figure B-18.

Figure B-18 Example Methods for installing SSPT Type Spline

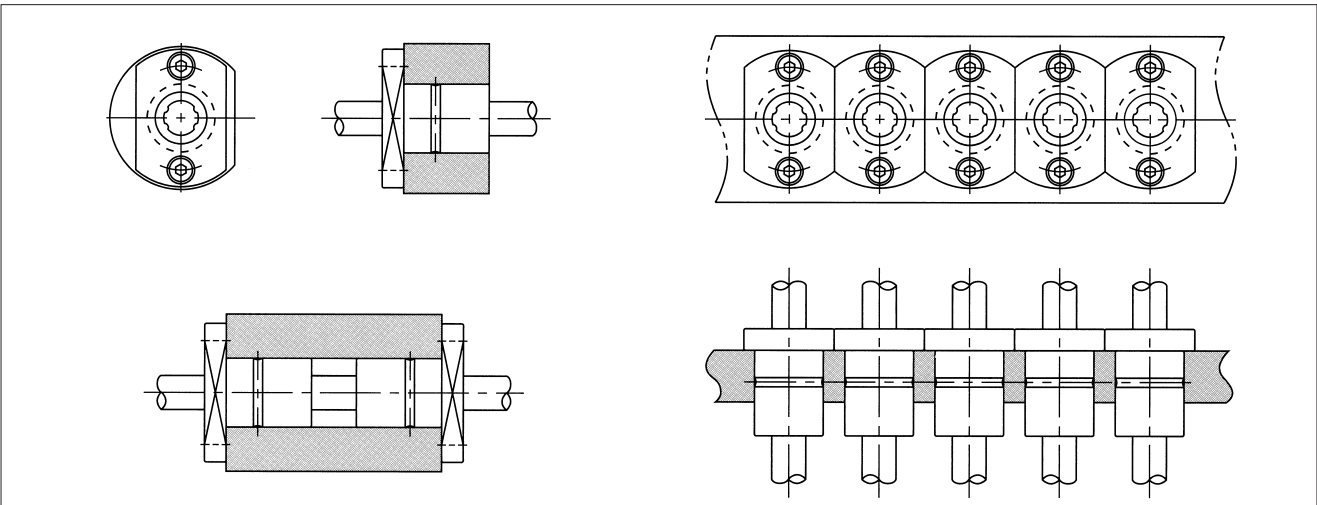

## Mounting of Block Type Spline:

Example methods for installing the block spline are shown in Figure B-19.

Figure B-19 Example Methods for installing Block Type Spline

