

SLIDE GUIDE

BALL SPLINE  
ROTARY BALL SPLINE  
STROKE BALL SPLINE

TOPBALL® PRODUCTS

SLIDE BUSH

SLIDE UNIT

STROKE BUSH  
SLIDE ROTARY BUSH

SLIDE SHAFT

SLIDE WAY/GONIO WAY  
SLIDE TABLE  
MINIATURE SLIDE

ACTUATOR

SLIDE SCREW

# SLIDE UNIT

# SLIDE UNIT

A wide variety of linear motion slide units are available. Their high precision blocks increase the accuracy of machinery and other equipment. The blocks can be constructed of resin to reduce cost and weight. The use of standard shaft end supports and shaft support rails simplifies the components. The use of commercial units help to reduce design time and installation and component costs.

## TYPES

Table E-1





types		description		shaft support type	page
metric series	block type	SMA	 <p>housing material : aluminum alloy commonly used standard type inner contact diameter : <math>\phi 3\sim 60</math></p>	SH-A SH SHF	P.E-8
		SMA-W	 <p>double wide housing material : aluminum alloy inner contact diameter : <math>\phi 3\sim 60</math></p>		P.E-10
		AK	 <p>compact type housing material : aluminum alloy inner contact diameter : <math>\phi 6\sim 30</math></p>		P.E-12
		AK-W	 <p>compact type double wide housing material : aluminum alloy inner contact diameter : <math>\phi 6\sim 30</math></p>		P.E-14
		SMB	 <p>housing material : aluminum alloy inner contact diameter : <math>\phi 13\sim 40</math></p>		P.E-16

Table E-2

types		description		shaft support type	page	
metric series	block type	RB 	light weight housing material : resin cost effective inner contact diameter : $\phi 10\sim 20$	SH-A SH SHF	P.E-28	
	pillow block type	SMP 	self-aligning feature housing material : cast iron inner contact diameter : $\phi 13\sim 60$		P.E-18	
	adjustable type	SMJ 	clearance adjustable housing material : aluminum alloy inner contact diameter : $\phi 10\sim 60$		P.E-20	
	open type	SME		open type housing material : aluminum alloy suitable for a long distance application inner contact diameter : $\phi 10\sim 50$	SA	P.E-22
		SME-W		open type double wide moment resistant housing material : aluminum alloy inner contact diameter : $\phi 10\sim 30$		P.E-24
		SMD		open type clearance adjustable housing material : aluminum alloy inner contact diameter : $\phi 16\sim 30$		P.E-26

Table E-3











types		description		page
metric series	shaft supporter	SH-A 	shaft end supporter material : aluminum alloy (SH-A), cast iron (SH) inner contact diameter : $\phi 8\sim 60$ (SH-A), $\phi 10\sim 60$ (SH)	P.E-29
		SH 		P.E-30
		SHF/SHF-FC 		shaft end supporter flanged type material : aluminum alloy (SHF 10-60) cast iron (SHF-FC 35-60) inner contact diameter : $\phi 10\sim 60$
	shaft support rail	SA 	shaft support rail for open type block material : aluminum alloy maximum length : 600mm inner contact diameter : $\phi 10\sim 50$	P.E-32
	assembly	CE(compact type) 	open type block and support rail assembly easy installation cost performance available clearance adjustable type and compact block type standard maximum length : 2,000mm longer length are available Please contact NB in case of the length exceeds 2,000mm inner contact diameter : $\phi 16\sim 30$	P.E-34
		CD(adjustable type) 		P.E-36

Table E-4

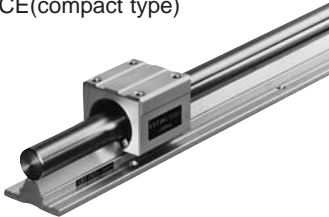
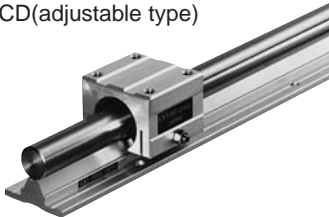
types		description		shaft support type	page
inch series	block type	SWA 	housing material : aluminum alloy inner contact diameter : $\phi 1/4" \sim 2"$	WH-A	P.E-38
	adjustable type	SWJ 	clearance adjustable housing material : aluminum alloy inner contact diameter : $\phi 1/2" \sim 2"$		P.E-40
	open type	SWD 	open type clearance adjustable housing material : aluminum alloy inner contact diameter : $\phi 1/2" \sim 2"$	WA	P.E-42
	resin block type	RBW 	anti-corrosion light weight housing material : resin cost effective inner contact diameter : $\phi 1/2" \sim 1"$	WH-A	P.E-44
	shaft supporter	WH-A 	shaft end supporter material : aluminum alloy inner contact diameter : $\phi 1/4" \sim 2"$	-	P.E-45
	shaft support rail	WA 	shaft support rail for open type block material : aluminum alloy maximum length : 24" inner contact diameter : $\phi 1/2" \sim 2"$		P.E-46

See C-1 TOPBALL PRODUCTS.

## ACCURACY

The accuracy of the SA type and CE/CD-types support rails are measured as shown in Figure E-1.

Figure E-1 Measurement Method

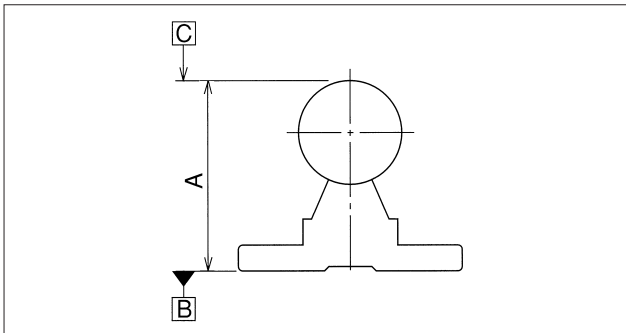

Figure E-2 Accuracy of SA Type Support

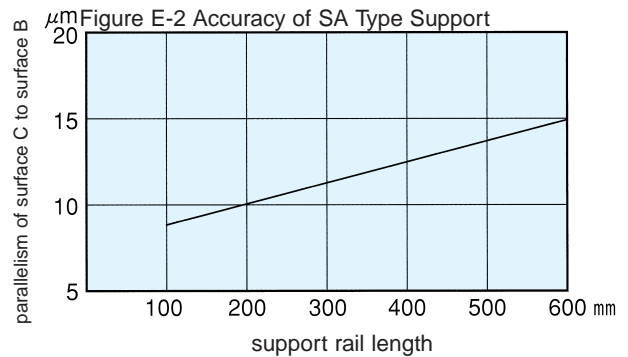
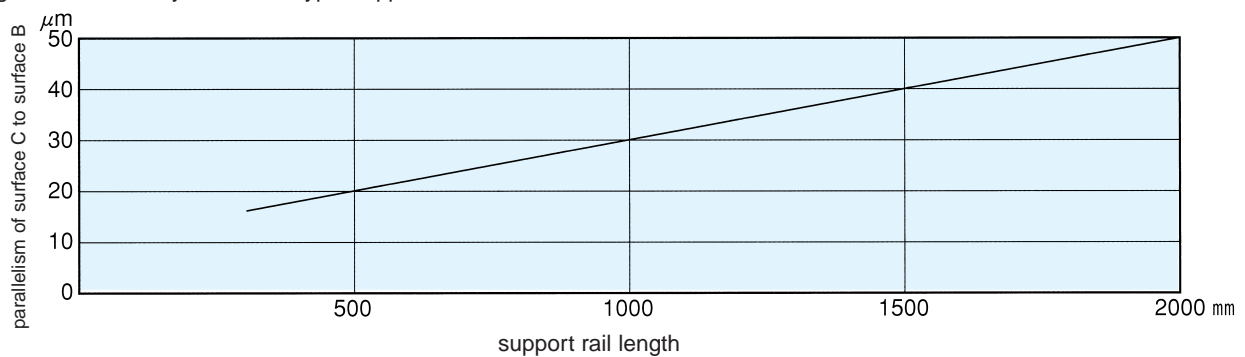

Figure E-3 Accuracy of CE/CD-Type Support Rails



## LIFE

The life of a slide unit is estimated using the following equations, which are similar to that of a slide bushing.

Travel life:

$$L = \left( \frac{f_H \cdot f_T \cdot f_C}{f_W} \cdot \frac{C}{P} \right)^3 \cdot 50$$

L : travel life (km)  $f_H$  : hardness coefficient  $f_T$  : temperature coefficient  
 $f_C$  : contact coefficient  $f_W$  : load coefficient C : dynamic load rating(N)  
 P : applied load(N)

※ When an open-type slide unit is used with the load in the direction shown in Figure E-4, the load rating must be calibrated using the coefficients listed in Table E-5.

Table E-5 Calibration Coefficients for Load Rating

part number		coefficient
SME(D)10G-16G	CE(D)16G	0.64
SME(D)20G	CE(D)20G	0.54
SME(D)25G-50G	CE(D)25G-30G	0.57

Contact NB for information on using steel retainers.

Life time:

$$L_h = \frac{L \cdot 10^3}{2 \cdot l_s \cdot n_1 \cdot 60}$$

$L_h$  : life time(hr)  $l_s$  : stroke distance (m)  
 $n_1$  : stroke frequency per min. (cpm)

Figure E-4 Load Direction

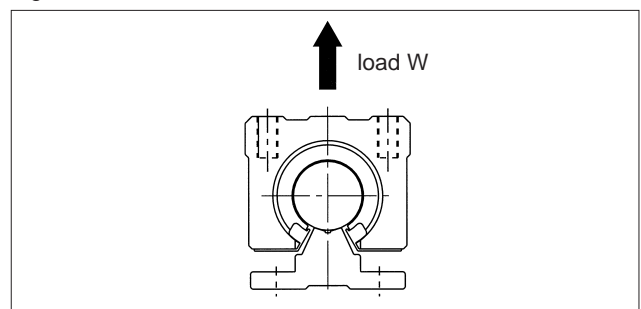

## NOTES ON USAGE

### Reference Surface:

A reference surface is provided with NB slide units as a standard feature. Excellent accuracy can be achieved by simply pushing the reference surface against the shoulder of the installation surface. (Excludes RB/RBW/SMP types)

### Clearance Adjustment:

The adjustment of pre-load for the slide unit must be done carefully so that pre-load is not excessive. Care should be taken not to apply excessive torque when tightening the screws.

### Mounting of RB Type Unit:

RB type unit has a resin housing. Mounting should be done using the proper torque values given in Table E-6.

### Recommended Fit:

A standard grade slide bush is installed in NB slide units. For clearance and transition fit, g6 and h6 tolerance shafts, respectively, should be used. (Excludes adjustable-clearance type and open type)

### Example: Special Installation Case of SMJ Type Slide Unit

When installing a Clearance Adjustable Unit such as illustrated in Figure D-6, please consult with NB. Special mounting holes will be required to allow for installations such as this.

Figure E-5 Reference Surface

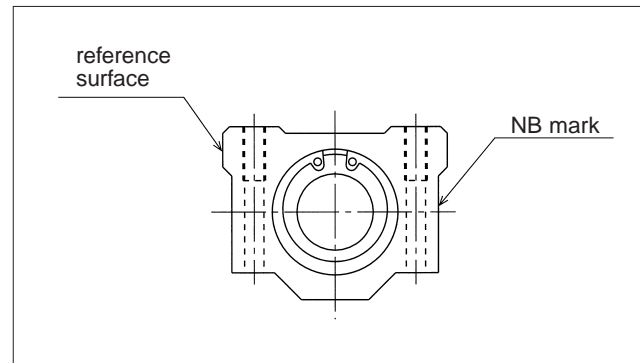

Table E-6 Torque Values

part number	mounting bolt	torque N·m
RB10~16	M4	1.8
RB20	M5	5.3

Figure D-6 Example: Special Installation Case of SMJ Type Slide Unit

