

TKA TYPE

— Block Type —

(Metric Series)

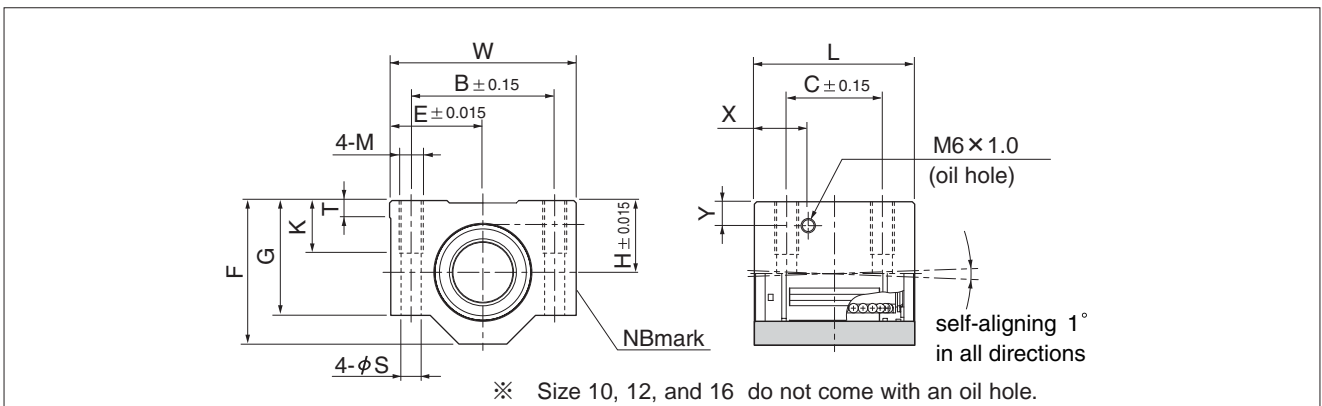
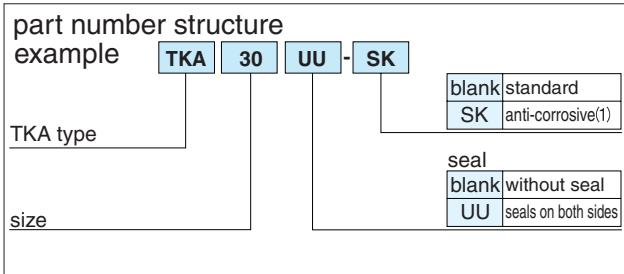

part number	nom. shaft dia. mm	major dimensions									mounting dimensions					load rating		mass g
		H	E	W	L	F	G	T	X	Y	B	C	M	K	S	dynamic C N	static Co N	
		mm	mm	mm	mm	mm	mm	mm	mm	mm	mm	mm	mm	mm	mm	mm	mm	
TKA10UU	10	16	20	40	36	31.5	25	5	—	—	29	20	M 5	11	4.3	750	935	90
TKA12UU	12	18	21.5	43	39	35	28	5	—	—	32	23	M 5	11	4.3	1020	1290	116
TKA16UU	16	22	26.5	53	43	42	35	5	—	—	40	26	M 6	13	5.3	1250	1550	205
TKA20UU	20	25	30	60	54	50	42	5	19	9	45	32	M 8	18	6.6	2090	2630	326
TKA25UU	25	30	39	78	67	60	48	7	22.5	10	60	40	M10	22	8.4	3780	4720	624
TKA30UU	30	35	43.5	87	79	70	58	8	26	11.5	68	45	M10	22	8.4	5470	6810	980
TKA40UU	40	45	54	108	91	90	72	10	26.5	14	86	58	M12	26	10.5	6590	8230	1670

recommended shaft tolerance is h6

1N≒0.102kgf

(1) For anti-corrosion the load plates are electroless nickel plated with Stainless Steel ball elements.

TKA-W TYPE

— Double-Wide Block Type —

(Metric Series)

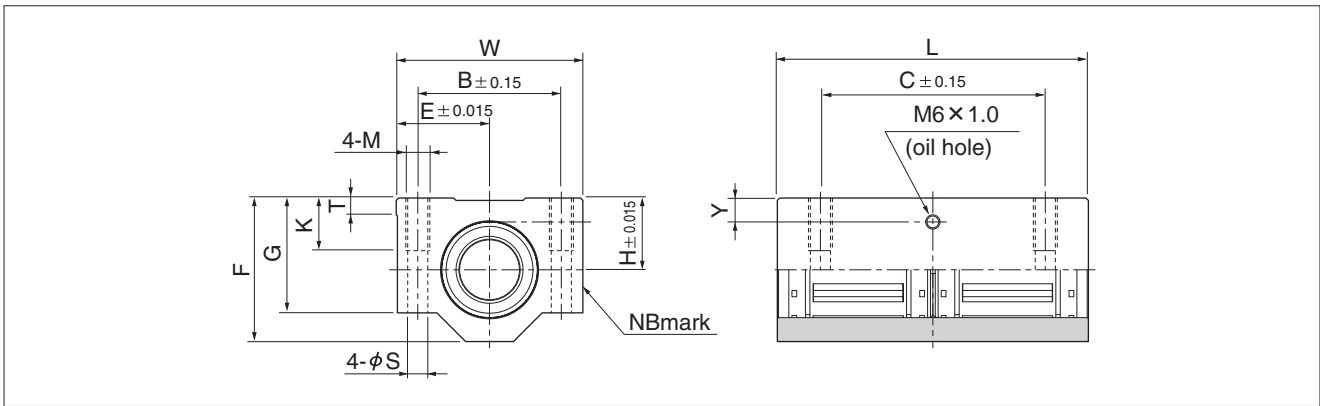
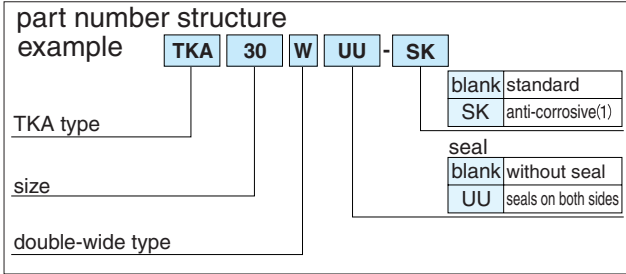
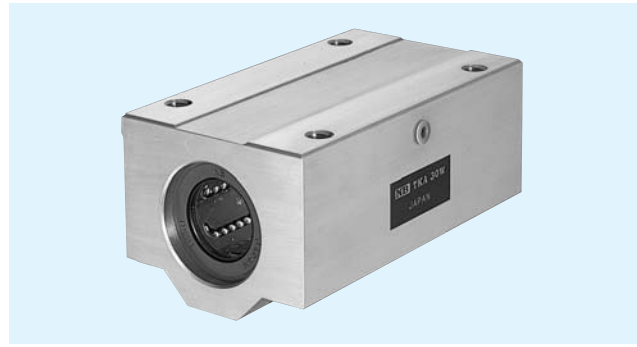

part number	nom. shaft dia. mm	major dimensions							mounting dimensions						load rating		mass g
		H	E	W	L	F	G	T	Y	B	C	M	K	S	dynamic C N	static Co N	
		mm	mm	mm	mm	mm	mm	mm	mm	mm	mm	mm	mm	mm	mm	mm	
TKA10WUU	10	16	20	40	70	31.5	25	5	7	29	52	M 5	11	4.3	1215	1870	175
TKA12WUU	12	18	21.5	43	76	35	28	5	7.5	32	56	M 5	11	4.3	1652	2580	227
TKA16WUU	16	22	26.5	53	84	42	35	5	9.5	40	64	M 6	13	5.3	2025	3100	390
TKA20WUU	20	25	30	60	104	50	42	5	9	45	76	M 8	18	6.6	3390	5260	630
TKA25WUU	25	30	39	78	130	60	48	7	10	60	94	M10	22	8.4	6120	9440	1210
TKA30WUU	30	35	43.5	87	152	70	58	8	11.5	68	106	M10	22	8.4	8860	13620	1880
TKA40WUU	40	45	54	108	176	90	72	10	14	86	124	M12	26	10.5	10680	16460	3280

(1) For anti-corrosion the load plates are electroless nickel plated with Stainless Steel ball elements.

1N≐0.102kgf

TKE TYPE

– Open Block Type –

(Metric Series)

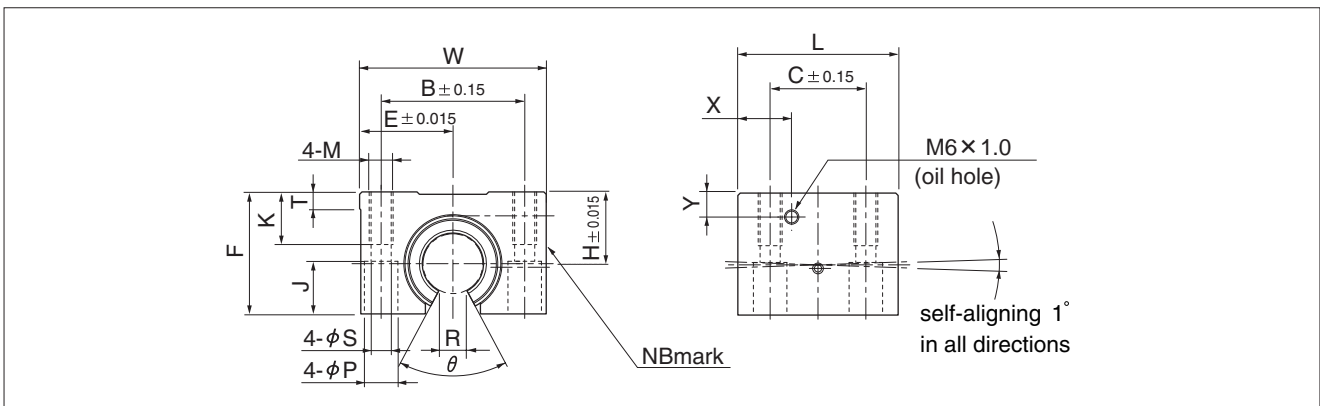
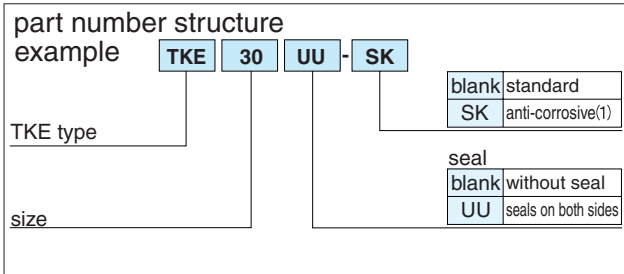
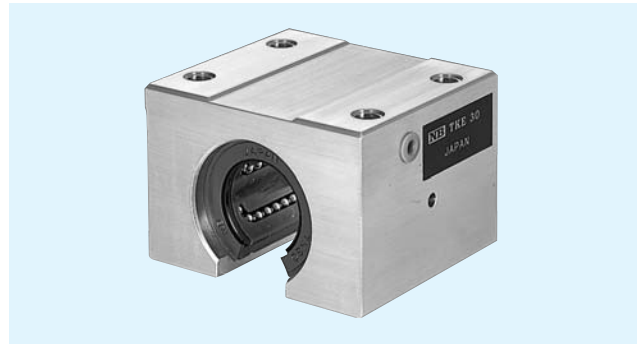

part number	nom. shaft dia. mm	major dimensions									mounting dimensions								load rating		mass g
		H	E	W	L	F	T	R	θ	X	Y	B	C	M	K	S	P	J	dynamic C N	static Co N	
TKE12UU	12	18	21.5	43	39	28	5	6.5	66°	14.5	7.5	32	23	M 5	11	4.3	8	4.5	1020	1290	99
TKE16UU	16	22	26.5	53	43	35	5	9	68°	15.5	9.5	40	26	M 6	13	5.3	9.5	5.5	1250	1550	175
TKE20UU	20	25	30	60	54	42	5	9	55°	19	9	45	32	M 8	18	6.6	11	6.5	2090	2630	275
TKE25UU	25	30	39	78	67	51	7	11.5	57°	22.5	10	60	40	M10	22	8.4	14	8.6	3780	4720	558
TKE30UU	30	35	43.5	87	79	60	8	14	57°	26	11.5	68	45	M10	22	8.4	14	8.6	5470	6810	860
TKE40UU	40	45	54	108	91	77	10	19.5	56°	26.5	14	86	58	M12	26	10.5	17.5	10.8	6590	8230	1490

(1) For anti-corrosion the load plates are electroless nickel plated with Stainless Steel ball elements.

1N≒0.102kgf

TKE-W TYPE

– Double-Wide Open Block Type –
(Metric Series)

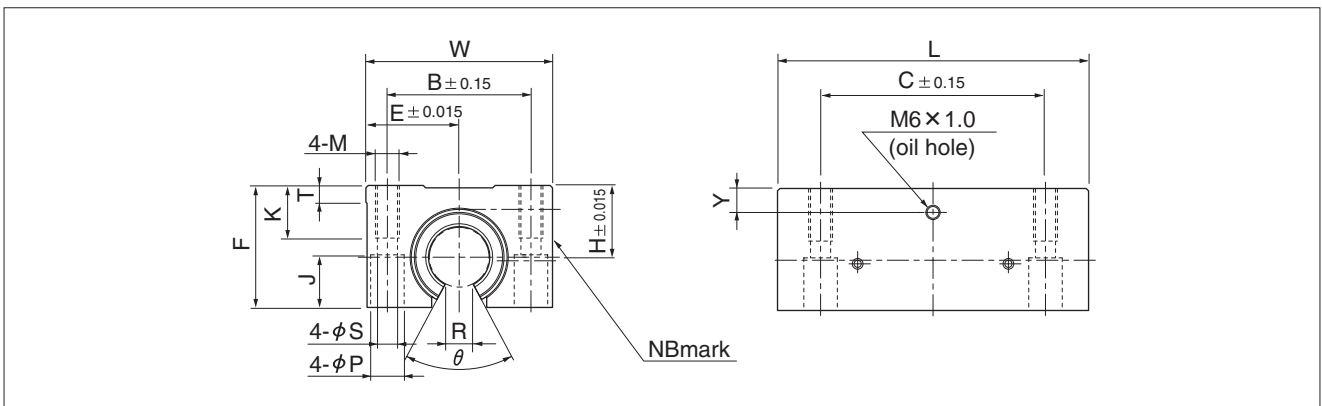
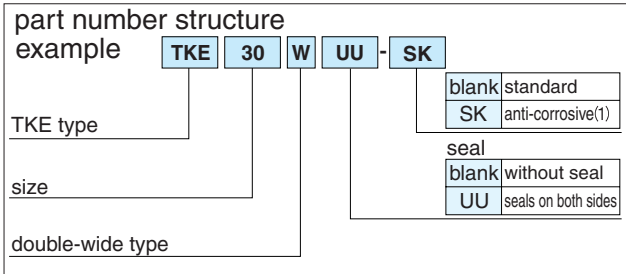
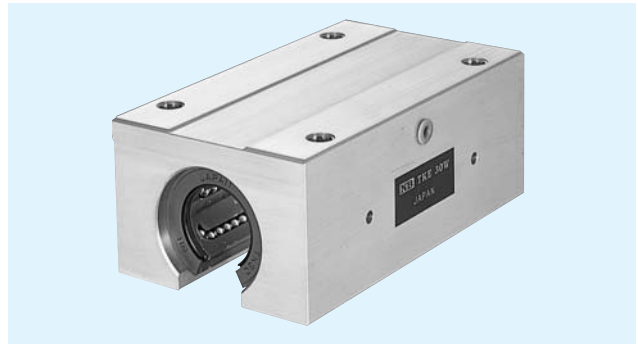

part number	nom. shaft dia. mm	major dimensions									mounting dimensions							load rating		mass g
		H	E	W	L	F	T	R	θ	Y	B	C	M	K	S	P	J	dynamic C N	static Co N	
		mm	mm	mm	mm	mm	mm	mm	mm	mm	mm	mm	mm	mm	mm	mm	mm			
TKE12WUU	12	18	21.5	43	76	28	5	6.5	66°	7.5	32	56	M 5	11	4.3	8	4.5	1652	2580	190
TKE16WUU	16	22	26.5	53	84	35	5	9	68°	9.5	40	64	M 6	13	5.3	9.5	5.5	2025	3100	312
TKE20WUU	20	25	30	60	104	42	5	9	55°	9	45	76	M 8	18	6.6	11	6.5	3390	5260	505
TKE25WUU	25	30	39	78	130	51	7	11.5	57°	10	60	94	M10	22	8.4	14	8.6	6120	9440	1050
TKE30WUU	30	35	43.5	87	152	60	8	14	57°	11.5	68	106	M10	22	8.4	14	8.6	8860	13620	1630
TKE40WUU	40	45	54	108	176	77	10	19.5	56°	14	86	124	M12	26	10.5	17.5	10.8	10680	16460	2880

(1) For anti-corrosion the load plates are electroless nickel plated with Stainless Steel ball elements.

1N≒0.102kgf

TKD TYPE

– Clearance Adjustable Open Block Type –
(Metric Series)

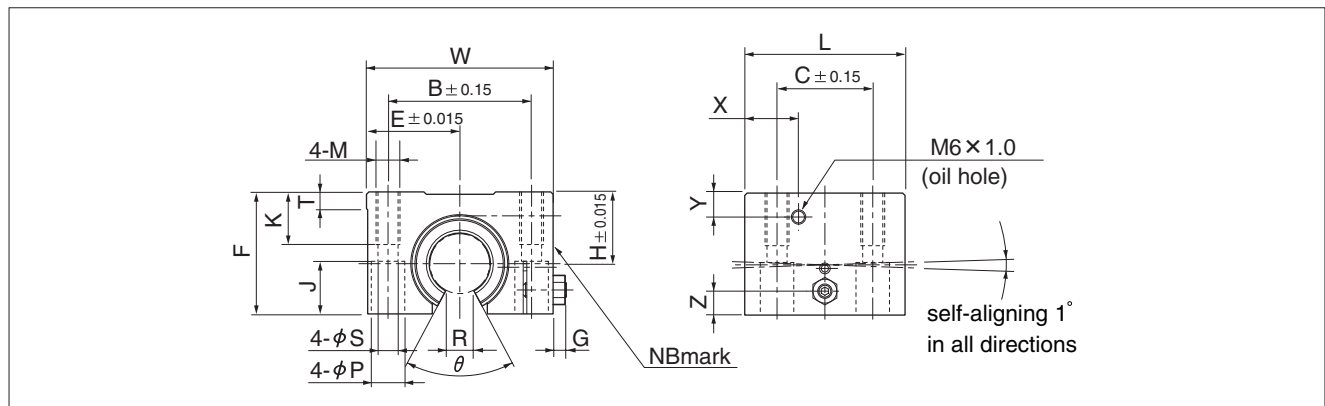
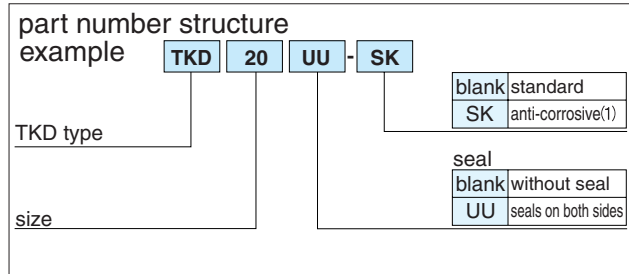
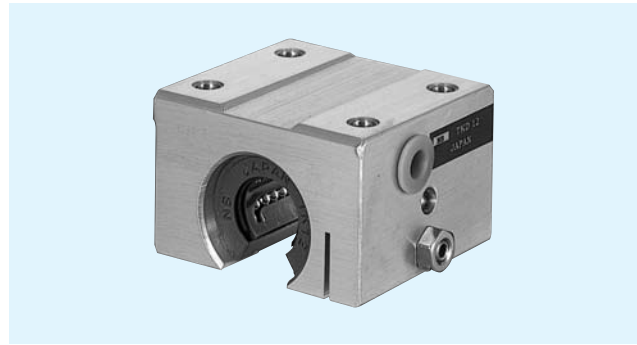

part number	nom. shaft dia. mm	major dimensions										mounting dimensions							load rating		mass g		
		H	E	W	L	F	G	Z	T	R	θ	X	Y	B	C	M	K	S	P	J		dynamic C N	static Co N
		mm	mm	mm	mm	mm	mm	mm	mm	mm	mm	mm	mm	mm	mm	mm	mm	mm	mm	mm		mm	mm
TKD12UU	12	18	21.5	43	39	28	3.2	5	5	6.5	66°	14.5	7.5	32	23	M 5	11	4.3	8	11.5	1020	1290	99
TKD16UU	16	22	26.5	53	43	35	3.2	6	5	9	68°	15.5	9.5	40	26	M 6	13	5.3	9.5	14	1250	1550	175
TKD20UU	20	25	30	60	54	42	4	8	5	9	55°	19	9	45	32	M 8	18	6.6	11	18	2090	2630	275
TKD25UU	25	30	39	78	67	51	5.5	10	7	11.5	57°	22.5	10	60	40	M10	22	8.4	14	22	3780	4720	558
TKD30UU	30	35	43.5	87	79	60	5.5	12	8	14	57°	26	11.5	68	45	M10	22	8.4	14	26	5470	6810	860
TKD40UU	40	45	54	108	91	77	5	15	10	19.5	56°	26.5	14	86	58	M12	26	10.5	17.5	33	6590	8230	1490

(1) For anti-corrosion the load plates are electroless nickel plated with Stainless Steel ball elements.

1N≐0.102kgf

TKD-W TYPE

— Clearance Adjustable Double-Wide Open Block Type —
(Metric Series)

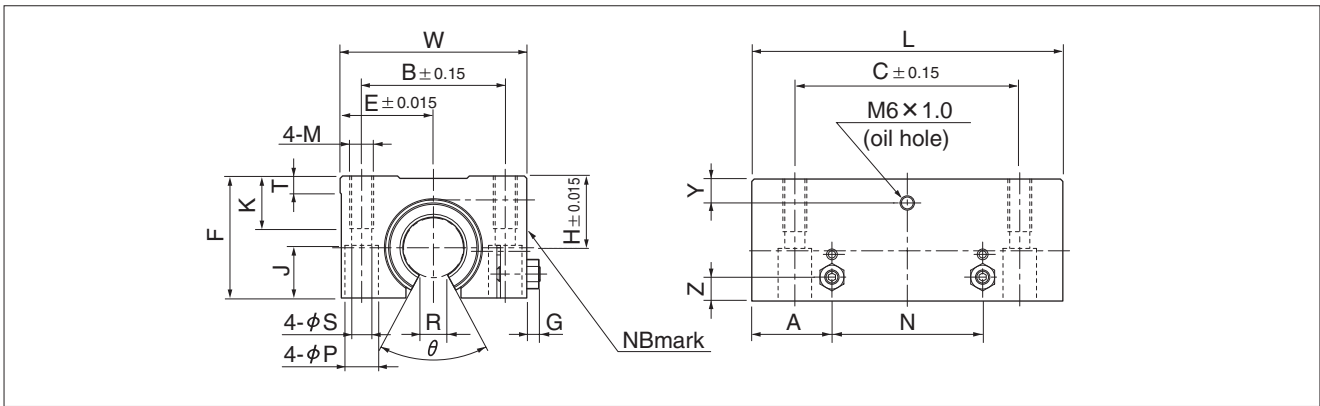
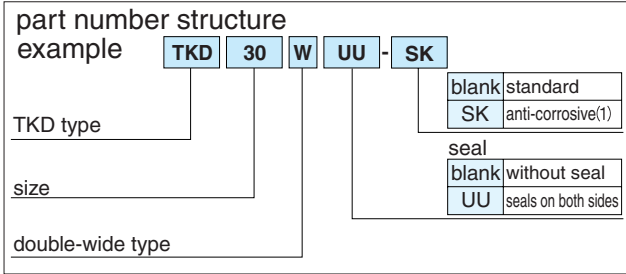

part number	nom. shaft dia. mm	major dimensions													mounting dimensions							load rating		mass g
		H	E	W	L	F	G	Z	A	N	T	R	θ	Y	B	C	M	K	S	P	J	dynamic C N	static Co N	
		mm	mm	mm	mm	mm	mm	mm	mm	mm	mm	mm	mm	mm	mm	mm	mm	mm	mm	mm	mm	mm	mm	
TKD12WUU	12	18	21.5	43	76	28	3.2	5	19.5	37	5	6.5	66°	7.5	32	56	M 5	11	4.3	8	11.5	1652	2580	190
TKD16WUU	16	22	26.5	53	84	35	3.2	6	21.5	41	5	9	68°	9.5	40	64	M 6	13	5.3	9.5	14	2025	3100	312
TKD20WUU	20	25	30	60	104	42	4	8	27	50	5	9	55°	9	45	76	M 8	18	6.6	11	18	3390	5260	505
TKD25WUU	25	30	39	78	130	51	5.5	10	33.5	63	7	11.5	57°	10	60	94	M10	22	8.4	14	22	6120	9440	1050
TKD30WUU	30	35	43.5	87	152	60	5.5	12	39.5	73	8	14	57°	11.5	68	106	M10	22	8.4	14	26	8860	13620	1630
TKD40WUU	40	45	54	108	176	77	5	15	45.5	85	10	19.5	56°	14	86	124	M12	26	10.5	17.5	33	10680	16460	2880

(1) For anti-corrosion the load plates are electroless nickel plated with Stainless Steel ball elements.

1N≐0.102kgf