



TECHNICAL

REFERENCE

DEFINITIONS AND DESIGNATIONS OF GEOMETRICAL DEVIATIONS (JIS B0621)

TOLERANCING OF FORM, ORIENTATION, LOCATION AND RUN-OUT (JIS B0021)

STRAIGHTNESS Straightness indicates the degree of deviation of a straight portion from the geometrical straight line.

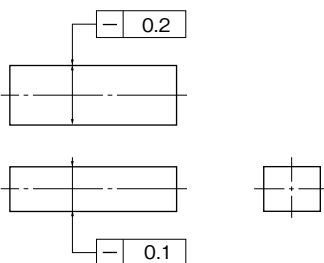
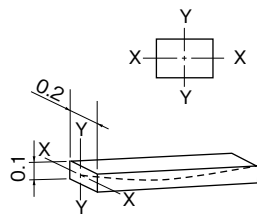
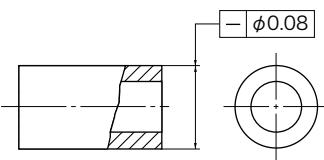
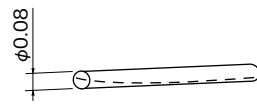
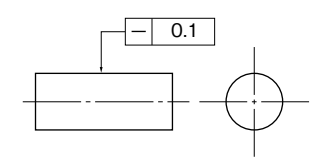
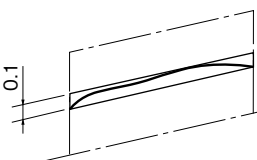
<p>Straightness of two directions perpendicular to each other (Axis of a rectangular parallelepiped)</p> 	<p>Space inside the prism enclosed by two pairs of parallel planes with intervals of 0.2mm and 0.1mm in the directions of indicated arrows</p> 
<p>Straightness with no direction defined (Axis of a cylinder)</p> 	<p>Space inside a cylinder with a diameter of 0.08mm</p> 
<p>Straightness of a surface element (Generatrix of a cylinder)</p> 	<p>Space between a pair of parallel straight lines with an interval of 0.1mm on an arbitrary plane including the axis</p> 

FLATNESS Flatness indicates the degree of deviation of a flat portion from the geometrical plane.

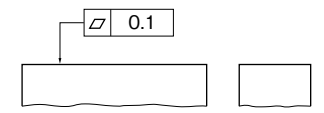
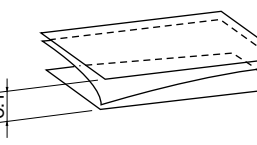
<p>General flatness</p> 	<p>Space between a pair of parallel planes with an interval of 0.1mm</p> 
---	--

CIRCULARITY Circularity indicates the degree of deviation of a circular portion from the geometrical circle.

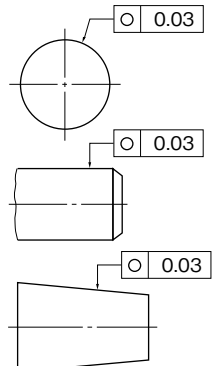
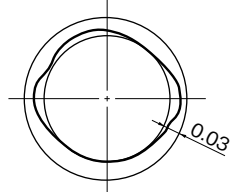
	<p>Space between two concentric circles with a radius difference of 0.03mm. Applicable to an arbitrary cross section perpendicular to the axis.</p> 
---	---

CYLINDRICITY Cylindricity indicates the degree of deviation of a cylindrical portion from the geometrical cylindrical surface.

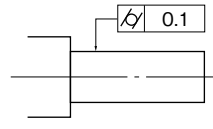
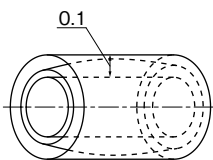
	<p>Space between two concentric cylinders with a radius difference of 0.1mm</p> 
--	--

PARALLELISM Parallelism assumes a combination of two straight portions, a straight portion and a flat portion, or two flat portions which must be parallel to each other. Parallelism indicates, with one of the two portions as a reference, the degree of deviation of the other straight or flat portion from the geometrical straight line or plane parallel to the reference straight line or plane.

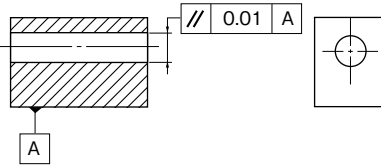
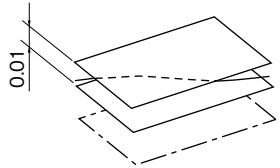
<p>Parallelism of a straight portion with respect to the reference plane (Axis of a hole)</p> 	<p>Space between two parallel planes with an interval of 0.01mm, parallel to the reference plane</p> 
---	--

PERPENDICULARITY Perpendicularity assumes a combination of two straight portions, a straight portion and a flat portion, or two flat portions which must be perpendicular to each other. Perpendicularity indicates, with one of the two portions as a reference, the degree of deviation of the other straight or flat portion from the geometrical straight line or plane.

Perpendicularity of a flat portion with respect to the reference straight line (with the axis of a cylinder as a reference)

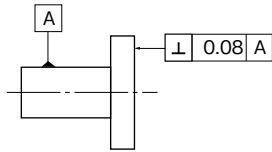

Space between two parallel planes with an interval of 0.08mm, perpendicular to the reference straight line

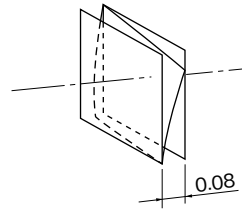

Perpendicularity of a flat portion with respect to the reference plane

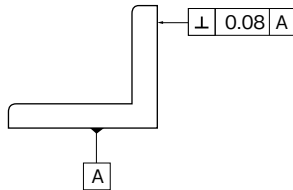

Space between two parallel planes with an interval of 0.08mm, perpendicular to the reference plane

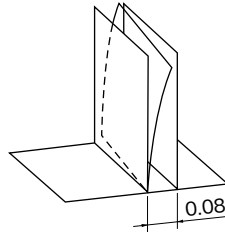

CONCENTRICITY Concentricity indicates the degree of deviation from the axis which must be on the same straight line as the reference axis.

Concentricity of a cylindrical portion

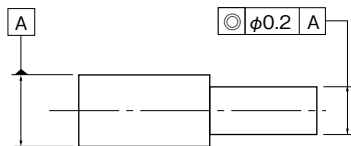

Space inside a cylinder with a diameter of 0.2mm, concentric with the reference axis

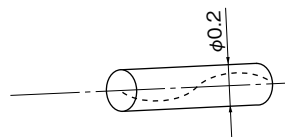

Hardness Conversion Table

Rockwell C scale hardness HRC (load 150kg)	Vickers Hardness HV	Brinell hardness HBW		Rockwell hardness		Shore hardness HS
		standard sphere	tungsten sphere	HRA A scale load 60 kg brale pressure point	HRBS B scale load 100 kg 1/16-inch-diameter sphere	
68	940	—	—	85.6	—	97
67	900	—	—	85.0	—	95
66	865	—	—	84.5	—	92
65	832	—	739	83.9	—	91
64	800	—	722	83.4	—	88
63	772	—	705	82.8	—	87
62	746	—	688	82.3	—	85
61	720	—	670	81.8	—	83
60	697	—	654	81.2	—	81
59	674	—	634	80.7	—	80
58	653	—	615	80.1	—	78
57	633	—	595	79.6	—	76
56	613	—	577	79.0	—	75
55	595	—	560	78.5	—	74
54	577	—	543	78.0	—	72
53	560	—	525	77.4	—	71
52	544	500	512	76.8	—	69
51	528	487	496	76.3	—	68
50	513	475	481	75.9	—	67
49	498	464	469	75.2	—	66
48	484	451	455	74.7	—	64
47	471	442	443	74.1	—	63
46	458	432	432	73.6	—	62
45	446	421	421	73.1	—	60
44	434	409	409	72.5	—	58
43	423	400	400	72.0	—	57
42	412	390	390	71.5	—	56
41	402	381	381	70.9	—	55
40	392	371	371	70.4	—	54
39	382	362	362	69.9	—	52
38	372	353	353	69.4	—	51
37	363	344	344	68.9	—	50
36	354	336	336	68.4	(109.0)	49
35	345	327	327	67.9	(108.5)	48
34	336	319	319	67.4	(108.0)	47
33	327	311	311	66.8	(107.5)	46
32	318	301	301	66.3	(107.0)	44
31	310	294	294	65.8	(106.0)	43
30	302	286	286	65.3	(105.5)	42
29	294	279	279	64.7	(104.5)	41
28	286	271	271	64.3	(104.0)	41
27	279	264	264	63.8	(103.0)	40
26	272	258	258	63.3	(102.5)	38
25	266	253	253	62.8	(101.5)	38
24	260	247	247	62.4	(101.0)	37
23	254	243	243	62.0	100.0	36
22	248	237	237	61.5	99.0	35
21	243	231	231	61.0	98.5	35
20	238	226	226	60.5	97.8	34
(18)	230	219	219	—	96.7	33
(16)	222	212	212	—	95.5	32
(14)	213	203	203	—	93.9	31
(12)	204	194	194	—	92.3	29
(10)	196	187	187	—	90.7	28
(8)	188	179	179	—	89.5	27
(6)	180	171	171	—	87.1	26
(4)	173	165	165	—	85.5	25
(2)	166	158	158	—	83.5	24
(0)	160	152	152	—	81.7	24

Shaft Dimensional Tolerance

diameter category mm greater than or less than	a13		c12		d6		e6		f5		f6		g5		g6		h5		h6		h7		h8		h9		h10			
	upper	lower	upper	lower	upper	lower	upper	lower	upper	lower	upper	lower	upper	lower	upper	lower	upper	lower	upper	lower	upper	lower	upper	lower	upper	lower	upper	lower	upper	lower
—	3	-270	-410	-60	-160	-20	-26	-14	-20	-6	-10	-6	-12	-2	-6	-2	-8	0	-4	0	-6	0	-10	0	-14	0	-25	0	-40	0
3	6	-270	-450	-70	-190	-30	-38	-20	-28	-10	-15	-10	-18	-4	-9	-4	-12	0	-5	0	-8	0	-12	0	-18	0	-30	0	-48	0
6	10	-280	-500	-80	-230	-40	-49	-25	-34	-13	-19	-13	-22	-5	-11	-5	-14	0	-6	0	-9	0	-15	0	-22	0	-36	0	-58	0
10	14	-290	-560	-95	-275	-50	-61	-32	-43	-16	-24	-16	-27	-6	-14	-6	-17	0	-8	0	-11	0	-18	0	-27	0	-43	0	-70	0
14	18	-300	-630	-110	-320	-65	-78	-40	-53	-20	-29	-20	-33	-7	-16	-7	-20	0	-9	0	-13	0	-21	0	-33	0	-52	0	-84	0
18	24	-310	-700	-120	-370	-80	-96	-50	-66	-25	-36	-25	-41	-9	-20	-9	-25	0	-11	0	-16	0	-25	0	-39	0	-62	0	-100	0
24	30	-320	-710	-130	-380	-90	-100	-60	-79	-30	-43	-30	-49	-10	-23	-10	-29	0	-13	0	-19	0	-30	0	-46	0	-74	0	-120	0
30	40	-340	-800	-140	-440	-100	-119	-70	-89	-40	-53	-40	-59	-11	-26	-11	-32	0	-15	0	-22	0	-35	0	-54	0	-91	0	-140	0
40	50	-360	-820	-150	-450	-110	-129	-80	-109	-50	-63	-50	-73	-12	-29	-12	-36	0	-17	0	-25	0	-40	0	-62	0	-100	0	-160	0
50	65	-380	-920	-170	-520	-120	-142	-90	-124	-60	-77	-60	-89	-13	-33	-13	-41	0	-19	0	-28	0	-45	0	-70	0	-110	0	-180	0
65	80	-410	-950	-180	-530	-130	-156	-100	-149	-70	-94	-70	-103	-14	-36	-14	-45	0	-21	0	-31	0	-50	0	-78	0	-120	0	-200	0
80	100	-460	-1090	-200	-600	-140	-180	-110	-169	-80	-113	-80	-131	-15	-40	-15	-49	0	-23	0	-34	0	-55	0	-85	0	-130	0	-220	0
100	120	-520	-1150	-210	-610	-150	-204	-120	-183	-90	-127	-90	-155	-16	-44	-16	-53	0	-25	0	-37	0	-58	0	-90	0	-140	0	-240	0
120	140	-580	-1210	-230	-630	-160	-228	-130	-207	-100	-141	-100	-169	-17	-48	-17	-57	0	-27	0	-40	0	-63	0	-98	0	-150	0	-260	0
140	160	-660	-1380	-240	-700	-170	-252	-140	-231	-110	-155	-110	-183	-18	-52	-18	-61	0	-29	0	-43	0	-68	0	-100	0	-160	0	-280	0
160	180	-740	-1460	-260	-720	-180	-276	-150	-255	-120	-169	-120	-207	-19	-56	-19	-65	0	-31	0	-46	0	-72	0	-110	0	-180	0	-300	0
180	200	-820	-1540	-280	-740	-190	-300	-160	-279	-130	-183	-130	-231	-20	-60	-20	-69	0	-33	0	-49	0	-78	0	-120	0	-200	0	-320	0
200	225	-920	-1730	-300	-820	-190	-324	-170	-303	-140	-207	-140	-255	-21	-64	-21	-73	0	-35	0	-52	0	-81	0	-130	0	-220	0	-340	0
225	250	-1050	-1860	-330	-850	-210	-348	-180	-327	-150	-231	-150	-279	-22	-68	-22	-77	0	-37	0	-56	0	-87	0	-140	0	-240	0	-360	0
250	280	-1200	-2090	-360	-930	-210	-372	-190	-351	-160	-255	-160	-303	-23	-72	-23	-81	0	-39	0	-60	0	-91	0	-150	0	-260	0	-380	0
280	315	-1350	-2240	-400	-970	-230	-408	-210	-395	-180	-289	-180	-347	-24	-76	-24	-85	0	-41	0	-64	0	-95	0	-160	0	-280	0	-400	0
315	355	-1500	-2470	-440	-1070	-230	-444	-210	-439	-190	-313	-190	-381	-25	-80	-25	-89	0	-43	0	-68	0	-100	0	-170	0	-300	0	-420	0
355	400	-1650	-2620	-480	-1110	-230	-480	-210	-475	-190	-347	-190	-415	-26	-84	-26	-93	0	-45	0	-72	0	-110	0	-180	0	-320	0	-440	0
400	450	-1800	-2820	-520	-1150	-230	-516	-210	-509	-190	-371	-190	-449	-27	-88	-27	-97	0	-47	0	-76	0	-120	0	-190	0	-340	0	-460	0
450	500	-2000	-3020	-560	-1190	-230	-552	-210	-543	-190	-405	-190	-483	-28	-92	-28	-101	0	-49	0	-80	0	-130	0	-200	0	-360	0	-480	0

Housing Bore Dimensional Tolerance

diameter category mm greater than or less than	E10		E11		F6		F7		F8		G6		G7		H5		H6		H7		H8		H9		H10				
	upper	lower	upper	lower	upper	lower	upper	lower	upper	lower	upper	lower	upper	lower	upper	lower	upper	lower	upper	lower	upper	lower	upper	lower	upper	lower	upper	lower	
—	3	+54	+14	+74	+14	+12	+6	+16	+6	+20	+6	+8	+2	+12	+2	+4	0	+6	0	+10	0	+14	0	+25	0	+40	0	0	0
3	6	+68	+20	+95	+20	+18	+10	+22	+10	+28	+10	+12	+4	+16	+4	+5	0	+8	0	+12	0	+18	0	+30	0	+48	0	0	0
6	10	+83	+25	+115	+25	+22	+13	+28	+13	+35	+13	+14	+5	+20	+5	+6	0	+9	0	+15	0	+22	0	+36	0	+58	0	0	0
10	14	+102	+32	+142	+32	+27	+16	+34	+16	+43	+16	+17	+6	+24	+6	+8	0	+11	0	+18	0	+27	0	+43	0	+70	0	0	0
14	18	+124	+40	+170	+40	+33	+20	+41	+20	+53	+20	+20	+7	+28	+7	+9	0	+13	0	+21	0	+33	0	+52	0	+84	0	0	0
18	24	+150	+50	+210	+50	+41	+25	+50	+25	+64	+25	+25	+9	+34	+9	+11	0	+16	0	+25	0	+39	0	+62	0	+100	0	0	0
24	30	+180	+60	+250	+60	+49	+30	+60	+30	+76	+30	+29	+10	+40	+10	+13	0	+19	0	+30	0	+46	0	+74	0	+120	0	0	0
30	40	+212	+72	+292	+72	+58	+36	+71	+36	+90	+36	+34	+12	+47	+12	+15	0	+22	0	+35	0	+54	0	+87	0	+140	0	0	0
40	50	+245	+85	+335	+85	+68	+43	+83	+43	+106	+43	+39	+14	+54	+14	+18	0	+25	0	+40	0	+63	0	+100	0	+160	0	0	0
50	65	+285	+100	+390	+100	+79	+50	+96	+50	+122	+50	+44	+15	+61	+15	+20	0	+29	0	+46	0	+72	0	+115	0	+185	0	0	0
65	80	+320	+110	+430	+110	+88	+56	+108	+56	+137	+56	+49	+17	+69	+17	+23	0	+32	0	+52	0	+81	0	+130	0	+210	0	0	0
80	100	+355	+125	+485	+125	+98	+62	+119	+62	+151	+62	+54	+18	+75	+18	+25	0	+36	0	+57	0	+89	0	+140	0	+230	0	0	0
100	120	+395	+135	+535	+135	+108	+68	+131	+68	+165	+68	+60	+20	+83	+20	+27	0	+40	0	+63	0	+97	0	+155	0	+250	0	0	0

unit : μm

diameter category mm greater than or less than	js5		js6		j5		j6		k5		k6		m5		m6		n5		n6		p5		p6		r6		r7				
	upper	lower	upper	lower	upper	lower	upper	lower	upper	lower	upper	lower	upper	lower	upper	lower	upper	lower	upper	lower	upper	lower	upper	lower	upper	lower	upper	lower	upper	lower	
—	3	±2	±3	±2	+4	-2	+4	0	+6	0	+6	+2	+8	+2	+8	+4	+10	+4	+10	+6	+12	+6	+16	+10	+20	+10	—	3	—	3	
3	6	±2.5	±4	+3	-2	+6	-2	+6	+1	+9	+1	+9	+4	+12	+4	+13	+8	+16	+8	+17	+12	+20	+12	+23	+15	+27	+15	3	6	3	6
6	10	±3	±4.5	+4	-2	+7	-2	+7	+1	+10	+1	+12	+6	+15	+6	+16	+10	+19	+10	+21	+15	+24	+15	+28	+19	+34	+19	6	10	6	10
10	14	±4	±5.5	+5	-3	+8	-3	+9	+1	+12	+1	+15	+7	+18	+7	+20	+12	+23	+12	+26	+18	+29	+18	+34	+23	+41	+23	10	14	10	14
14	18	±4.5	±6.5	+5	-4	+9	-4	+11	+2	+15	+2	+17	+8	+21	+8	+24	+15	+28	+15	+31	+22	+36									