

# CR TYPE

— Standard Curved Roller Cage —

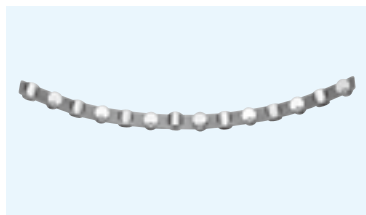

## part number structure

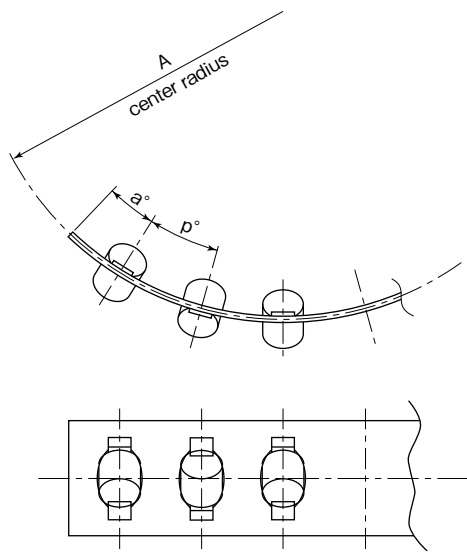
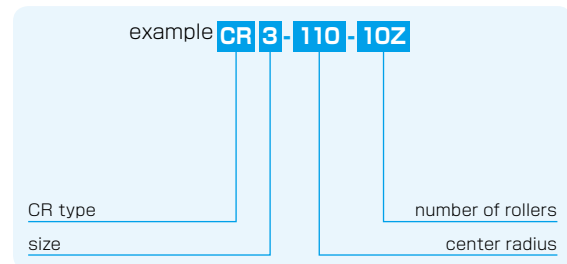

part number	roller diameter D mm	center radius A mm	t mm	w mm	p°	a°	applicable type
CR2- 50- 7Z	2	50	0.3	5.6	4.6°	2.9°	RV
CR2- 60-12Z		60			3.8°	2.4°	RV
CR2- 70-10Z		70			3.3°	2.0°	RVF
CR2- 87-10Z		87			2.6°	1.6°	RVF
CR2-103-10Z		103			2.2°	1.4°	RVF
CR2-120- 9Z		120			1.9°	1.2°	RVF
CR3- 85-10Z	3	85	0.4	7.2	3.4°	2.0°	RVF
CR3- 90-11Z		90			3.2°	1.9°	RV
CR3-110-10Z		110			2.6°	1.5°	RVF,RV
CR3-125-16Z		125			2.3°	1.3°	RVF
CR3-160-14Z		160			1.8°	1.0°	RVF,RV

# ACTUATOR

## ACTUATOR

- ADVANTAGES ..... H-3
- PART NUMBER STRUCTURE .. H-4
- SPECIFICATIONS ..... H-6
- ALLOWABLE SPEED AND STROKE LIMIT H-7
- ACCURACY ..... H-8
- RATED LIFE ..... H-10
- DIMENSION TABLE ..... H-14~29
- MOTOR BRACKET CONFIGURATIONS & APPLICABLE MOTORS H-30
- EXPOSED BRACKET RO ..... H-43
- RETURN PULLEY UNIT ..... H-46
- LOW HOUSING ..... H-48
- BELLOWS ..... H-50
- SENSOR ..... H-59
- PNP SENSOR ..... H-70
- SENSOR SPECIFICATIONS .... H-71
- POSITIONING PIN HOLE ..... H-74
- LUBRICATION ..... H-79
- OPERATING TEMPERATURE .. H-79
- USE AND HANDLING PRECAUTIONS H-79

# ACTUATOR

NB's BG type is a compact single axis actuator which integrates a slide guide and precision ball screw. BG type offers compact dimensions and outperforms conventional positioning tables.

This is made possible by a unique "U" shaped guide rail and slide block which provides multiple functions of a guide block and a ball screw nut combined into a single unit. The "U" shaped guide rail offers high rigidity against bending moment. This structural feature allows for integrated framework of machinery or equipment and can be cantilevered. Additionally, the slide block contains 4 ball circuits which delivers high load capacity, high accuracy and high rigidity.

Figure H-1 Structure of BG type

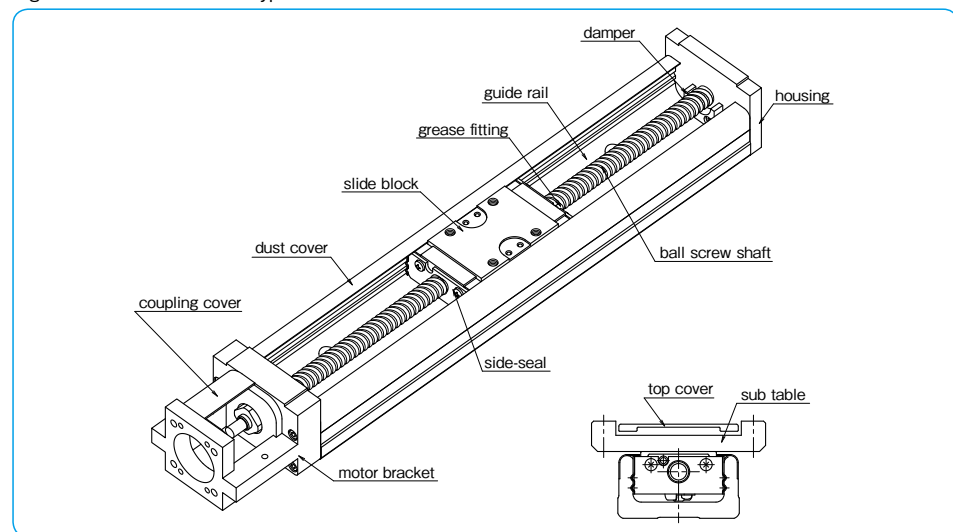
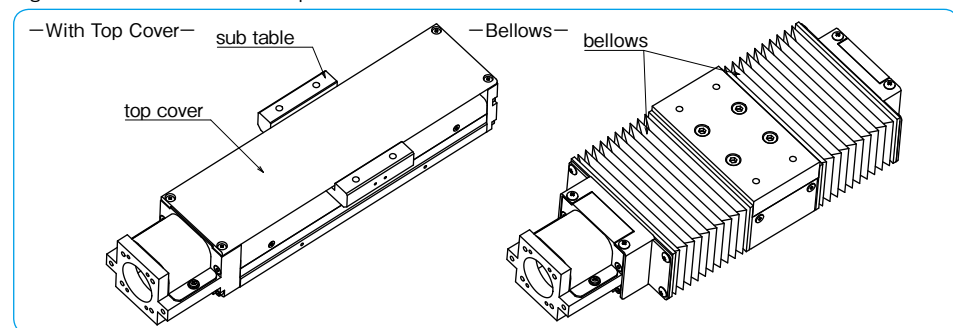

Figure H-2 Structure of With Top Cover and Bellows



H-2

## ADVANTAGES

### Adjustment Free

The integration of the slide guide and precision ball screw eliminates complex precision adjustment and reduces installation time dramatically.

### High Rigidity

Four-circuit and four-point contact structure and "U" shaped guide rail provide very high rigidity despite its compact configuration and can be used for cantilevered application.

### High Accuracy

BG type contains four ball circuits and four-point contact ball grooves which contribute to its high rigidity. The combination of precision ground guide rail, slide block and precision ball screw provides high positioning accuracy.

### Space Saving

In comparison to conventional positioning tables, the BG type allows for compact designs and dramatic space saving. The "U" shaped guide rail and integrated slide block and precision ball screw make this possible.

By utilizing four-circuit and four-point contact structure, the BG type provides extremely high rigidity. Figure H-3 shows displacement of each size of long block against radial load. Table H-3 shows the moment of inertia of area of guide rails.

Figure H-3 Block Displacement against Radial Load

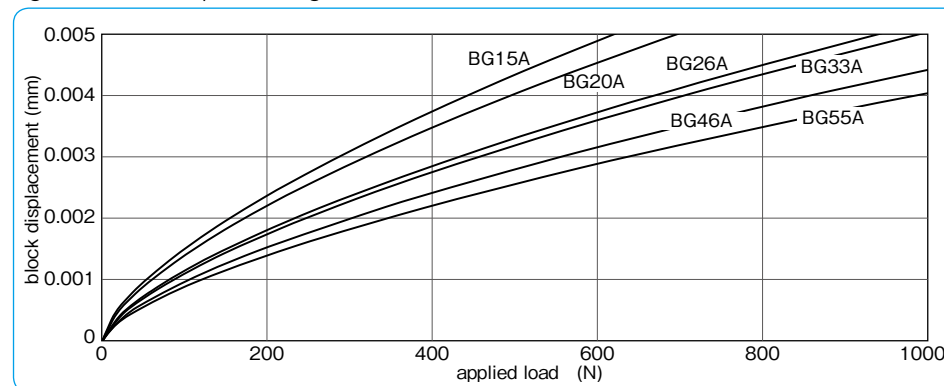

Figure H-4 Ball Contact Profile

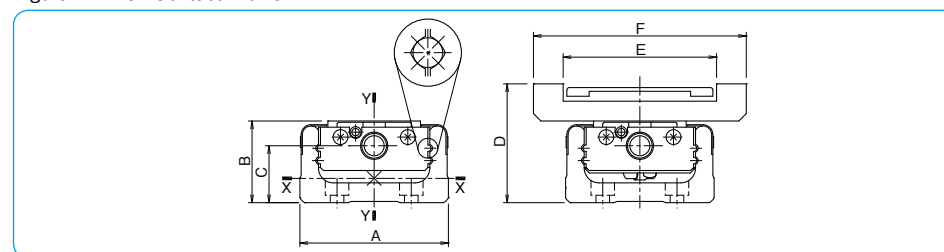

Table H-1 Moment of Inertia of Area of Guide Rail

part number	A	B	C	D	E	F	moment of inertia of area (mm <sup>4</sup> )		mass W (kg/100mm)
							I <sub>x</sub> (X Axis)	I <sub>y</sub> (Y Axis)	
<b>BG15</b>	30	15	9.5	25	32	44	1.22×10 <sup>3</sup>	1.56×10 <sup>4</sup>	0.12
<b>BG20</b>	40	20	12.5	32	37	52	6.50×10 <sup>3</sup>	6.00×10 <sup>4</sup>	0.25
<b>BG26</b>	50	26	16	40	47	62	1.69×10 <sup>4</sup>	1.47×10 <sup>5</sup>	0.38
<b>BG33</b>	60	33	23	48	62	86	5.11×10 <sup>4</sup>	3.42×10 <sup>5</sup>	0.60
<b>BG46</b>	86	46	32	68	88	112	2.42×10 <sup>5</sup>	1.49×10 <sup>6</sup>	1.24
<b>BG55</b>	100	55	32	80	95	124	2.29×10 <sup>5</sup>	2.28×10 <sup>6</sup>	1.50

H-3

PART NUMBER STRUCTURE

Part number for BG type is described as follows.

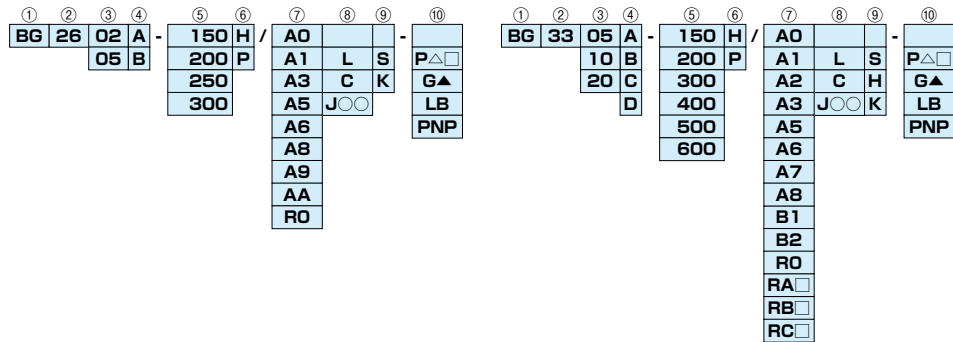
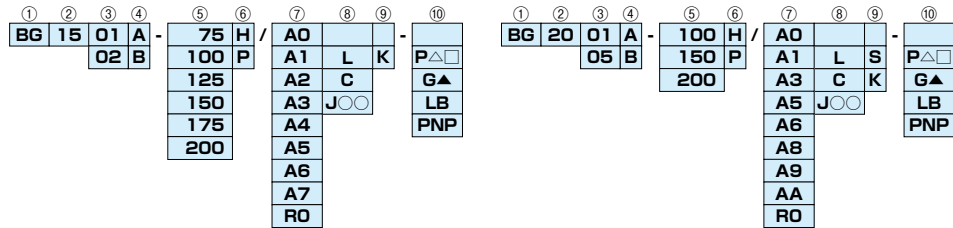

※Short blocks are not available for BG3320.

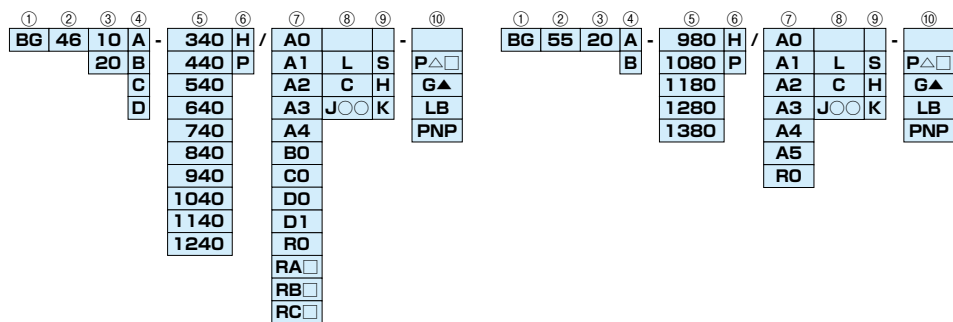

There is limitation on the length of rails depending on block type and accuracy grade. Please refer to page H-7,8.

- ① BG type
- ② size
- ③ ball screw lead
- ④ type of block

A:1 long block

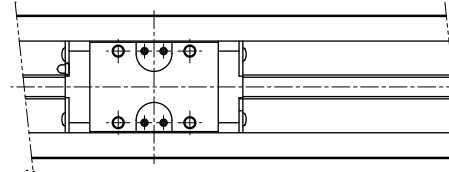

B:2 long blocks

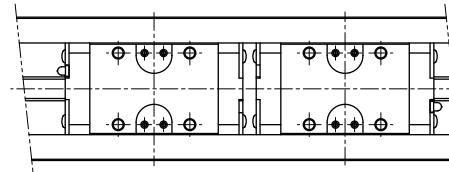

C:1 short block

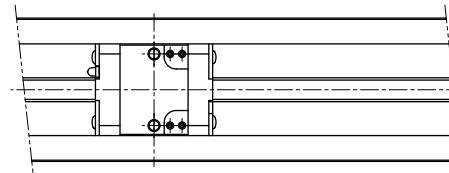

D:2 short blocks

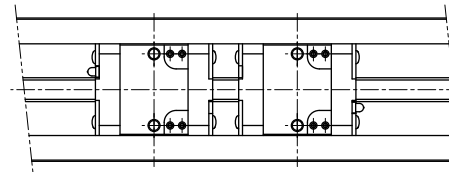

※ Drive block is located closest to motor bracket side.

⑦ guide rail length

※Precision grade(P) has limitation on the length of rails. Please refer to page H-8.

⑥ accuracy grade (P.H-8)

H	high grade
P	precision grade

⑦ motor bracket (refer to page H-30,H-31)

The number in the square, □, after suffix RA, RB or RC indicates the mounting direction code. (refer to page H-46)

- ⑧ cover, low housing and bellows
- none: without top cover (P.H-14~)

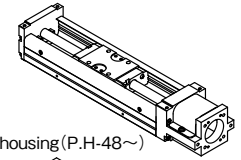

L:low housing (P.H-48~)

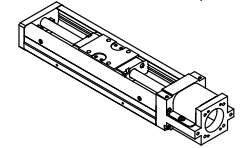

C: with top cover + sub table (P.H-15~)

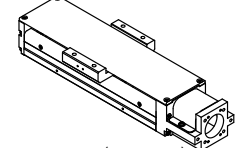

JOO: with bellows (P.H-50~)

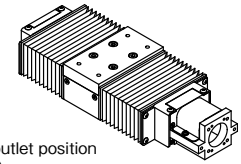

OO sensor cable outlet position (refer to page H-50)

⑨ sensor (P.H-59~)

none	without sensor
S	with slim-type / compact photomicro sensor
H	with close contact capable photomicro sensor
K	with proximity sensor

⑩ option

none	without option
P△□	with positioning pin hole (※1)
G▲	with special grease option (※2)
LB	with low temperature black chrome treatment (※3)
PNP	with PNP sensor

In case of multiple options, add + between each option. Example: (PS+LB+PNP)

※1: △ is S, W or R (refer to page H-74)

□ is R (refer to page H-74)

※2: ▲ is U, L or F (refer to page H-79)

Grease is applied to slide guide, ball screw, and angular bearings.

※3: LB is applied to steel parts except for aluminum parts and radial bearings.

For BG15, LB is applied to steel parts except for the drive block, aluminum parts, and radial bearings.

Black chrome treatment is applied to the drive block.

SPECIFICATIONS

BG Type is categorized as either high grade (H) or precision grade (P). Precision grade(P) has limitation on the length of rails. Please refer to page H-8.

Table H-2 Specifications

part number		BG1501		BG1502		BG2001		BG2005		BG2602		BG2605		BG3305		BG3310		BG3320		BG4610		BG4620		BG5520					
precision grade		high	Precision	high	Precision	high	Precision	high	Precision	high	Precision	high	Precision	high	Precision	high	Precision	high	Precision	high	Precision	high	Precision	high	Precision	high	Precision		
guide	radial clearance	μm -2~0 -4~-2 -2~0 -4~-2 -3~-0 -6~-3 -3~-0 -6~-3 -4~-0 -8~-4 -4~-0 -8~-4 -3~-0 -7~-3 -3~-0 -7~-3 -3~-0 -7~-3 -5~-0 -11~-5 -5~-0 -11~-5 -6~-0 -18~-6																											
	basic dynamic load C	kN 2.42		4.27		7.87		12.6		29.8		43.2																	
		kN 4.76		7.89		14.98		22.7		51.2		74.0																	
	long block	basic static load Co	N·m 17		35		99		181		610		1,088																
			N·m 92		199		550		1,035		3,285		5,465																
		allowable static moment	My	N·m 20		42		118		215		727		1,297															
			Mz1	N·m 110		237		656		1,233		3,914		6,513															
			Me	N·m 51		101		255		500		1,612		2,701															
			MzR	N·m 102		201		509		1,000		3,224		5,402															
	short block	basic dynamic load C	kN -		-		-		7.8		-		19.9		-		-		-		-		-		-		-		
			kN -		-		-		11.4		-		28.8		-		-		-		-		-		-		-		
		allowable static moment	My	N·m -		-		-		49		-		207		-		-		-		-		-		-		-	
Mz1			N·m -		-		-		368		-		1,336		-		-		-		-		-		-		-		
Me			N·m -		-		-		59		-		246		-		-		-		-		-		-		-		
MzR			N·m -		-		-		439		-		1,593		-		-		-		-		-		-		-		
shaft diameter	mm 6		6		8		10		12		15		20																
	mm 1 2		1 5		2 5		5 10		20 10		20 20																		
ball screw	lead	mm -		-		-		-		-		-		-		-		-		-		-		-		-			
	spacer-ball ratio	-		-		-		-		-		-		-		-		-		-		-		-		-			
bearing support	basic dynamic load Ca	kN 0.39 0.54		0.63 0.65		2.60 2.35		3.35 2.11 2.20 1.39 2.32 1.46 4.40 2.77 4.40 3.36 5.40 4.12																					
	basic static load Coa	kN 0.77 0.75		1.34 0.92		3.64 3.30		5.90 2.95 3.50 1.75 4.05 2.02 7.90 3.95 7.90 5.27 10.5 7.00																					
part number	-		AC4-12DF		AC5-14DF		AC6-16DF		70M8DF/GMP5		7001T2DF/GMP5		7002T2DF/GMP5																
	kN 1.21		1.31		1.79		4.40		6.77		7.74																		
basic static load Cob		kN 1.08		1.25		1.76		4.36		7.45		9.50																	

MzP, MzY and MzR are the allowable static moments when 2 blocks are used in close contact.  
 ※ Please consult with NB when using BG15, BG20 and BG26 series in the Precision grade with short and frequent stroke. (short stroke: BG1501= 2mm or less, BG1502= 4mm or less, BG2001= 7mm or less, BG2005= 25mm or less, BG2602= 14mm or less and BG2605= 25mm or less)  
 Short blocks are not available for BG3320.

Figure H-5 Direction of Moment

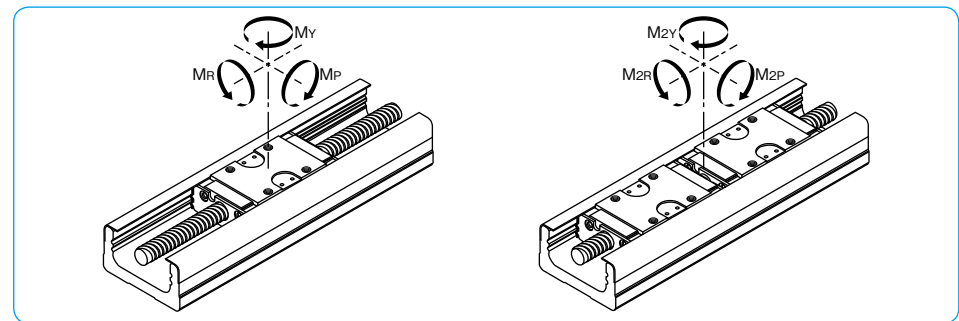

ALLOWABLE SPEED AND STROKE LIMIT

Allowable speed of BG type is subject to the type of motor and operating conditions. The speed may also be limited by the critical speed of the ball screw. Use caution when operating at high speeds or using long rails.

Table H-3 ALLOWABLE SPEED AND STROKE LIMIT

part number	rail length	stroke limit (mm)				speed (mm/sec)		
		1 long block	2 long blocks	1 short block	2 short blocks	lead1	lead2	
BG15	75	30	-	-	-	185	370	
	100	55	-	-	-			
	125	80	46	-	-			
	150	105	71	-	-			
	175	130	96	-	-			
200	155	121	-	-	-	-		
BG20	100	43	-	-	-	187	925	
	150	93	51	-	-			
	200	143	101	-	-			
	200	143	101	-	-			
BG26	150	73	-	-	-	281	694	
	200	123	61	-	-			
	250	173	111	-	-			
	300	223	161	-	-			
BG33	150	60	-	85	34	550	1,100	1,500
	200	110	-	135	84			
	300	210	133	235	184			
	400	310	233	335	284			
	500	410	333	435	384			
	600	510	433	535	484			
	600	510	433	535	484			
310	620							
BG46	340	209	100	245	172	740	1,480	
	440	309	200	345	272			
	540	409	300	445	372			
	640	509	400	545	472			
	740	609	500	645	572			
	840	709	600	745	672			
	940	809	700	845	772			
	1,040	909	800	945	872			
	1,140	1,009	900	1,045	972			
	1,240	1,109	1,000	1,145	1,072			
220	440							
BG55	980	834	711	-	-	-	-	-
	1,080	934	811	-	-			
	1,180	1,034	911	-	-			
	1,280	1,134	1,011	-	-			
	1,380	1,234	1,111	-	-			
	1,380	1,234	1,111	-	-			

Short block type is not available for lead 20.

Figure H-6 Guide Rail Length and Allowable Speed

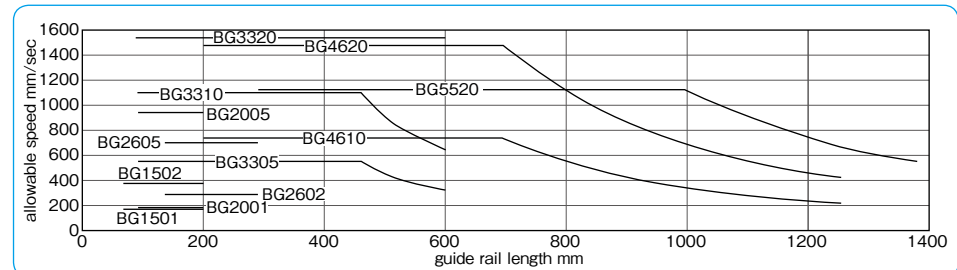

ACCURACY

Table H-4 shows accuracy of BG type.

Table H-4 Accuracy

part number	rail length mm	positioning repeatability		positioning accuracy		running parallelism B		backlash		※starting torque		
		high μm	precision μm	high μm	precision μm	high μm	precision μm	high μm	precision μm	high N·m	precision N·m	
BG15	75	±3	±1	40	20	20	10	5	2	0.01	0.012	
	100											
	125											
	150											
	175											
200												
BG20	100	±3	±1	50	20	25	10	5	2	0.01	0.012	
	150											
	200											
BG26	150	±3	±1	50	20	25	10	5	2	0.015	0.04	
	200											
	250											
	300											
BG33	150	±3 (±5)	±1 (±3)	30	15	25	10	5	2	0.07	0.15	
	200			35	20							
	300			40	25							15
	400			70	—							—
	500			—	—							—
BG46	340	±3 (±5)	±1 (±3)	35	20	35	15	5	2	0.10	0.15	
	440			40	25							
	540			50	30							20
	640			80	—							—
	740			—	—							—
	840			—	—							—
	940			—	—							—
	1,040			—	—							—
	1,140			—	—							—
	1,240			—	—							—
BG55	980	±3	±1	80	35	50	25	5	2	0.12	0.17	
	1,080			40	30							
	1,180			—	—							—
	1,280			—	—							—
	1,380			—	—							—

Above values are measured by using our selected motors.  
 ※ Above specifications are based on using NB standard grease. Other grease may cause deviations.  
 The values in the parentheses are positioning repeatability when used with return pulley unit.

Positioning Repeatability

After setting an arbitrary position, from one end, move the drive block to this position and measure the stop position. Repeat the positioning and measurement process 7 times with respect to the setting position at the midpoint and near both ends of travel. Take the maximum difference and divide it by 2, then indicate it with a positive and negative sign as the test result.

Positioning Repeatability

$$= \pm \frac{1}{2} (\text{maximum value of } \ell_n - \text{minimum value of } \ell_n)$$

Figure H-7 Positioning Repeatability

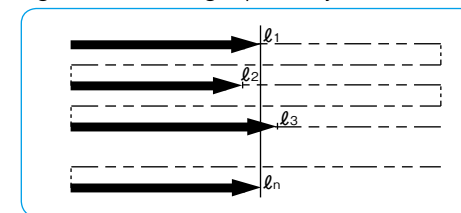

Positioning Accuracy

Positioning is performed in one direction and the resulting position is set as the datum point. Take the difference between the actual travel distance and the commanded travel distance from the datum point. Continuing in the same direction (without returning to the start point) repeat this process randomly several times until nearing to the stroke limit. Express the accuracy by the absolute maximum difference.

$$\text{Positioning Accuracy} = (\Delta \ell_n)_{\max}$$

Figure H-8 Positioning Accuracy

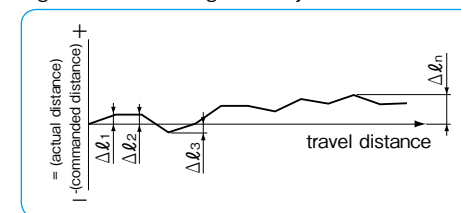

Running Parallelism B

After fixing the guide rail onto the surface plate, placing the dial test indicator on the center of the slide block and connecting the indicator probe onto the mounting surface, run the block over the entire travel distance. Take the maximum deviation in readings as the test result.

Figure H-9 Running Parallelism

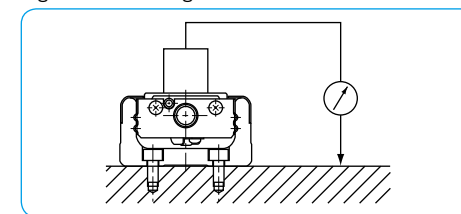

Backlash

Using the feed screw to move the slide block a little, take the dial test indicator reading and make it the datum point. While in this position, thrust the block by a certain force in the same direction without using the feed screw. Release the thrust and read the return, then take the difference from the datum point. Repeat the same process at the midpoint and near both ends of travel. Take the maximum difference as the test result.

$$\text{Backlash} = \Delta \ell$$

Figure H-10 Backlash

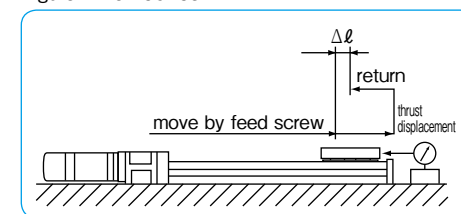

**RATED LIFE**

To obtain the rated life of the BG type, calculate the rated life of the guide portion, ball screw portion and support bearing portion. Use the minimum value as the rated life of the BG type.

**A. Life of Guide Portion**

Use the following equation for calculating the rated life of guide portion.

$$L_G = \left( \frac{f_c}{f_w} \cdot \frac{C}{P_T} \right)^3 \cdot 50 \dots\dots\dots (1)$$

$L_G$ : rated life (km)  $f_c$ : contact coefficient (refer to Table H-5)  
 $f_w$ : applied load coefficient (refer to Table H-6)  
 $C$ : basic dynamic load rating (N)  
 $P_T$ : calculated load applied to one block (N)

**A.1. Calculation of  $P_T$**

Before calculating the rated life using the equation (1), the calculated load applied to one block ( $P_T$ ) needs to be obtained in consideration of the moment load, etc. that will be actually applied. For rapidly-accelerating or short stroke motion,  $P_T$  needs to be calculated with acceleration taken into consideration. The calculation of this acceleration will be carried out for the mass applied to BG. Obtain the calculated load during uniform motion, acceleration, and deceleration, and use the average value of the three as  $P_T$ .

For the calculation of  $P_T$ , select an appropriate equation depending on the installation conditions of the guide.

It is also possible to calculate  $P_T$  without including the effect of acceleration by using the equation " $P_T = P_{TC}$  (see the equations (2), (5), and (8)). In this case, however, the obtained value is a rough approximation, so a selection with sufficient margin is recommended.

Table H-5 Contact Coefficient ( $f_c$ )

number of blocks in close contact on one axis	contact coefficient ( $f_c$ )
1	1.0
2	0.81

Table H-6 Applied Load Coefficient ( $f_w$ )

operating conditions		applied load coefficient ( $f_w$ )
vibration, impact	velocity	
none	0.25m/s or less	1.0 ~ 1.5
low	1m/s or less	1.5 ~ 2.0
high	1m/s or more	2.0 ~ 3.5

Table H-7 Moment Equivalent Coefficient

	$E_p$ (E2p)	$E_y$ (E2y)	$E_r$ (E2r)
BG15 * * A	$2.82 \times 10^{-1}$	$2.37 \times 10^{-1}$	$9.35 \times 10^{-2}$
BG15 * * B	$5.16 \times 10^{-2}$	$4.33 \times 10^{-2}$	$4.67 \times 10^{-2}$
BG20 * * A	$2.25 \times 10^{-1}$	$1.89 \times 10^{-1}$	$7.84 \times 10^{-2}$
BG20 * * B	$3.98 \times 10^{-2}$	$3.34 \times 10^{-2}$	$3.92 \times 10^{-2}$
BG26 * * A	$1.51 \times 10^{-1}$	$1.27 \times 10^{-1}$	$5.88 \times 10^{-2}$
BG26 * * B	$2.72 \times 10^{-2}$	$2.28 \times 10^{-2}$	$2.94 \times 10^{-2}$
BG33 * * A	$1.26 \times 10^{-1}$	$1.06 \times 10^{-1}$	$4.55 \times 10^{-2}$
BG33 * * B	$2.20 \times 10^{-2}$	$1.84 \times 10^{-2}$	$2.27 \times 10^{-2}$
BG33 * * C	$2.31 \times 10^{-1}$	$1.94 \times 10^{-1}$	$4.55 \times 10^{-2}$
BG33 * * D	$3.09 \times 10^{-2}$	$2.59 \times 10^{-2}$	$2.27 \times 10^{-2}$
BG46 * * A	$8.39 \times 10^{-2}$	$7.04 \times 10^{-2}$	$3.17 \times 10^{-2}$
BG46 * * B	$1.56 \times 10^{-2}$	$1.31 \times 10^{-2}$	$1.59 \times 10^{-2}$
BG46 * * C	$1.39 \times 10^{-1}$	$1.17 \times 10^{-1}$	$3.17 \times 10^{-2}$
BG46 * * D	$2.15 \times 10^{-2}$	$1.81 \times 10^{-2}$	$1.59 \times 10^{-2}$
BG55 * * A	$6.80 \times 10^{-2}$	$5.71 \times 10^{-2}$	$2.74 \times 10^{-2}$
BG55 * * B	$1.35 \times 10^{-2}$	$1.14 \times 10^{-2}$	$1.37 \times 10^{-2}$

\*The E2 coefficient is for two blocks being used in close contact.

**A.1.a.  $P_T$  for Horizontal Move (Horizontal Mounting)**

i) during uniform motion ( $P_{TC}$ )

$$P_{TC} = \frac{1}{n} \cdot W + E_p \cdot M_{pL} + E_y \cdot M_{yL} + E_r \cdot M_{rL} \dots\dots\dots (2)$$

ii) during acceleration ( $P_{Ta}$ )

$$P_{Ta} = \frac{1}{n} \cdot W + E_p(M_{pL} + m \cdot \alpha_a \cdot Z) + E_y(M_{yL} + m \cdot \alpha_a \cdot X) + E_r \cdot M_{rL} \dots\dots\dots (3)$$

Note that the values of ( $M_{pL} + m \cdot \alpha_a \cdot Z$ ) and ( $M_{yL} + m \cdot \alpha_a \cdot X$ ) will be treated as 0 (zero) when the calculated value is negative.

iii) during deceleration ( $P_{Td}$ )

$$P_{Td} = \frac{1}{n} \cdot W + E_p(M_{pL} + m \cdot \alpha_d \cdot Z) + E_y(M_{yL} + m \cdot \alpha_d \cdot X) + E_r \cdot M_{rL} \dots\dots\dots (4)$$

Note that the values of ( $M_{pL} + m \cdot \alpha_d \cdot Z$ ) and ( $M_{yL} + m \cdot \alpha_d \cdot X$ ) will be treated as 0 (zero) when the calculated value is negative.

$P_{TC}$ : calculated load applied to a block during uniform motion (N)  $P_{Ta}$ : calculated load applied to a block during accelerating (N)  
 $P_{Td}$ : calculated load applied to a block during decelerating (N)  $n$ : number of blocks of BG  $W$ : applied load (N)  $m$ : carrying mass (kg)  
 $\alpha_a$ : acceleration during accelerating (m/sec<sup>2</sup>)  $\alpha_d$ : acceleration during decelerating (m/sec<sup>2</sup>) (the negative value)  
 $X$ : distance between the center of BG and the center of the carrying mass (mm)  
 $Y$ : distance between the center of BG and the center of the carrying mass (mm)  
 $Z$ : distance between the center of BG ball screw and the center of the carrying mass (mm)  
 $E_p$ : moment equivalent coefficient in the pitching direction (refer to Table H-7)  
 $E_y$ : moment equivalent coefficient in the yawing direction (refer to Table H-7)  
 $E_r$ : moment equivalent coefficient in the rolling direction (refer to Table H-7)  
 $M_{pL}$ : applied moment in the pitching direction (N · mm)  $M_{pL} = W \cdot Y$   
 $M_{yL}$ : applied moment in the yawing direction (N · mm)  $M_{yL} = 0$   
 $M_{rL}$ : applied moment in the rolling direction (N · mm)  $M_{rL} = W \cdot X$  \*Refer to Fig.H-5 for the direction of moment.

Figure H-11

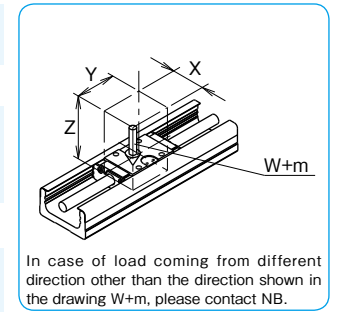

In case of load coming from different direction other than the direction shown in the drawing W+m, please contact NB.

**A.1.b.  $P_T$  for Horizontal Move (Wall Mounting)**

i) during uniform motion ( $P_{TC}$ )

$$P_{TC} = \frac{1}{1.19 \cdot n} \cdot W + E_p \cdot M_{pL} + E_y \cdot M_{yL} + E_r \cdot M_{rL} \dots\dots\dots (5)$$

ii) during acceleration ( $P_{Ta}$ )

$$P_{Ta} = \frac{1}{1.19 \cdot n} \cdot W + E_p(M_{pL} + m \cdot \alpha_a \cdot Z) + E_y(M_{yL} + m \cdot \alpha_a \cdot X) + E_r \cdot M_{rL} \dots\dots\dots (6)$$

Note that the values of ( $M_{pL} + m \cdot \alpha_a \cdot Z$ ) and ( $M_{yL} + m \cdot \alpha_a \cdot X$ ) will be treated as 0 (zero) when the calculated value is negative.

iii) during deceleration ( $P_{Td}$ )

$$P_{Td} = \frac{1}{1.19 \cdot n} \cdot W + E_p(M_{pL} + m \cdot \alpha_d \cdot Z) + E_y(M_{yL} + m \cdot \alpha_d \cdot X) + E_r \cdot M_{rL} \dots\dots\dots (7)$$

Note that the values of ( $M_{pL} + m \cdot \alpha_d \cdot Z$ ) and ( $M_{yL} + m \cdot \alpha_d \cdot X$ ) will be treated as 0 (zero) when the calculated value is negative.

$P_{TC}$ : calculated load applied to a block during uniform motion (N)  $P_{Ta}$ : calculated load applied to a block during accelerating (N)  
 $P_{Td}$ : calculated load applied to a block during decelerating (N)  $n$ : number of blocks of BG  $W$ : applied load (N)  $m$ : carrying mass (kg)  
 $\alpha_a$ : acceleration during accelerating (m/sec<sup>2</sup>)  $\alpha_d$ : acceleration during decelerating (m/sec<sup>2</sup>) (the negative value)  
 $X$ : distance between the center of BG and the center of the carrying mass (mm)  
 $Y$ : distance between the center of BG and the center of the carrying mass (mm)  
 $Z$ : distance between the center of BG ball screw and the center of the carrying mass (mm)  
 $E_p$ : moment equivalent coefficient in the pitching direction (refer to Table H-7)  $E_y$ : moment equivalent coefficient in the yawing direction (refer to Table H-7)  $E_r$ : moment equivalent coefficient in the rolling direction (refer to Table H-7)  
 $M_{pL}$ : applied moment in the pitching direction (N · mm)  $M_{pL} = 0$   
 $M_{yL}$ : applied moment in the yawing direction (N · mm)  $M_{yL} = W \cdot Y$   
 $M_{rL}$ : applied moment in the rolling direction (N · mm)  $M_{rL} = W \cdot Z$  \*Refer to Fig. H-5 for the direction of moment.

Figure H-12

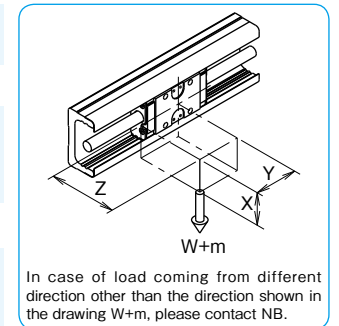

In case of load coming from different direction other than the direction shown in the drawing W+m, please contact NB.

**A.1.c. P<sub>T</sub> for Vertical Move**

i) during uniform motion (P<sub>Tc</sub>)

$$P_{Tc} = E_p \cdot M_{pL} + E_y \cdot M_{yL} + E_r \cdot M_{rL} \quad \dots \quad (8)$$

ii) during acceleration (P<sub>Ta</sub>)

$$P_{Ta} = E_p(M_{pL} + m \cdot \alpha_a \cdot Z) + E_y(M_{yL} + m \cdot \alpha_a \cdot X) + E_r \cdot M_{rL} \quad \dots \quad (9)$$

Note that the values of (M<sub>pL</sub>+m·α<sub>a</sub>·Z) and (M<sub>yL</sub>+m·α<sub>a</sub>·X) will be treated as 0 (zero) when the calculated value is negative.

iii) during deceleration (P<sub>Td</sub>)

$$P_{Td} = E_p(M_{pL} + m \cdot \alpha_d \cdot Z) + E_y(M_{yL} + m \cdot \alpha_d \cdot X) + E_r \cdot M_{rL} \quad \dots \quad (10)$$

Note that the values of (M<sub>pL</sub>+m·α<sub>d</sub>·Z) and (M<sub>yL</sub>+m·α<sub>d</sub>·X) will be treated as 0 (zero) when the calculated value is negative.

P<sub>Tc</sub>: calculated load applied to a block during uniform motion(N) P<sub>Ta</sub>: calculated load applied to a block during accelerating(N)  
 P<sub>Td</sub>: calculated load applied to a block during decelerating(N) n: number of blocks of BG W: applied load(N) m: carrying mass(kg)  
 α<sub>a</sub>: acceleration during accelerating(m/sec<sup>2</sup>) α<sub>d</sub>: acceleration during decelerating(m/sec<sup>2</sup>) (the negative value)  
 X: distance between the center of BG and the center of the carrying mass(mm)  
 Y: distance between the center of BG and the center of the carrying mass(mm)  
 Z: distance between the center of BG ball screw and the center of the carrying mass(mm)  
 E<sub>p</sub>: moment equivalent coefficient in the pitching direction (refer to Table H-7)  
 E<sub>y</sub>: moment equivalent coefficient in the yawing direction (refer to Table H-7)  
 E<sub>r</sub>: moment equivalent coefficient in the rolling direction (refer to Table H-7)  
 M<sub>pL</sub>: applied moment in the pitching direction (N·mm) M<sub>pL</sub>=W·Z M<sub>yL</sub>: loaded moment in the yawing direction (N·mm) M<sub>yL</sub>=W·X  
 M<sub>rL</sub>: applied moment in the rolling direction (N·mm) M<sub>rL</sub>=0 ※Refer to Fig. H-5 for the direction of moment.

Figure H-13

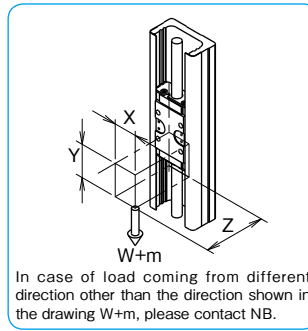

**A.1.d.**

Obtain the calculated load applied to a block (P<sub>T</sub>) by calculating the average load of each motion using an appropriate equation among those shown above according to the application.

$$P_T = \sqrt[3]{\frac{1}{S_1+S_2+S_3} (P_{Ta}^3 \cdot S_1 + P_{Tc}^3 \cdot S_2 + P_{Td}^3 \cdot S_3)} \quad \dots \quad (11)$$

P<sub>T</sub>: calculated load applied to one block (N)  
 S<sub>1</sub>: travel distance during acceleration (mm) (refer to Figure H-14)  
 S<sub>2</sub>: travel distance during uniform motion (mm) (refer to Figure H-14)  
 S<sub>3</sub>: travel distance during deceleration (mm) (refer to Figure H-14)  
 P<sub>Ta</sub>: calculated load applied to one block during accelerating (N): equation (3), (6), and (9)  
 P<sub>Tc</sub>: calculated load applied to one block during uniform motion (N): equation (2), (5), and (8)  
 P<sub>Td</sub>: calculated load applied to one block during decelerating (N): equation (4), (7), and (10)

Figure H-14

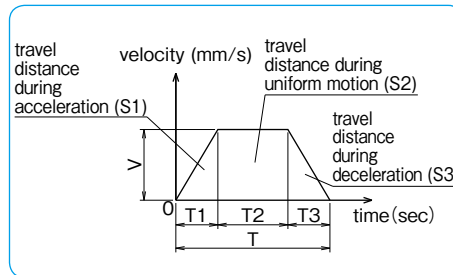

**B. Life of Ball Screw and Support Bearing**

The life of ball screw and support bearing can be calculated using a common equation, as shown below. Compare the dynamic load rating of the ball screw and the support bearing and apply smaller value for calculation.

$$L_a = \left( \frac{1}{f_w} \cdot \frac{C_a \text{ or } C_b}{P_a} \right)^3 \cdot \ell \quad \dots \quad (12)$$

L<sub>a</sub>: rated life (km) f<sub>w</sub>: applied load coefficient (refer to Table H-6)  
 C<sub>a</sub>: basic dynamic load rating of the ball screw (N)  
 C<sub>b</sub>: basic dynamic load rating of the support bearing (N)  
 P<sub>a</sub>: axial load (N) ℓ: ball screw lead (mm)

**B.1. Calculation of Pa**

Before calculating the life using the equation (12), calculate P<sub>a</sub> with acceleration taken into consideration. Calculate the load in each axial direction during uniform motion, acceleration, and deceleration and the obtained value is used as P<sub>a</sub>.

**B.1.a. For Horizontal Move**

i) during uniform motion (P<sub>ac</sub>)

$$P_{ac} = \mu \cdot W + F + f_b \cdot n \quad \dots \quad (13)$$

ii) during acceleration (P<sub>aa</sub>)

$$P_{aa} = \mu \cdot W + F + f_b \cdot n + (m + m_b \cdot n) \alpha_a \quad \dots \quad (14)$$

iii) during deceleration (P<sub>ad</sub>)

$$P_{ad} = \mu \cdot W + F + f_b \cdot n + (m + m_b \cdot n) \alpha_d \quad \dots \quad (15)$$

**B.1.b. For Vertical Move**

i) during uniform motion (P<sub>ac</sub>)

$$P_{ac} = (m + m_b \cdot n)g + F + f_b \cdot n \quad \dots \quad (16)$$

ii) during acceleration (P<sub>aa</sub>)

$$P_{aa} = (m + m_b \cdot n) \cdot (g + \alpha_a) + F + f_b \cdot n \quad \dots \quad (17)$$

iii) during deceleration (P<sub>ad</sub>)

$$P_{ad} = (m + m_b \cdot n) \cdot (g + \alpha_d) + F + f_b \cdot n \quad \dots \quad (18)$$

**B.1.c.**

Obtain the average axial load (P<sub>a</sub>) using an appropriate formula among those shown above depending on the application.

$$P_a = \sqrt[3]{\frac{1}{S_1+S_2+S_3} (P_{aa}^3 \cdot S_1 + P_{ac}^3 \cdot S_2 + P_{ad}^3 \cdot S_3)} \quad \dots \quad (19)$$

P<sub>a</sub>: average axial load (N)  
 S<sub>1</sub>: travel distance during acceleration (mm) (refer to Table H-14)  
 S<sub>2</sub>: travel distance during uniform motion (mm) (refer to Table H-14)  
 S<sub>3</sub>: travel distance during deceleration (mm) (refer to Table H-14)  
 P<sub>aa</sub>: axial load during accelerating (N): formulas (14) and (17)  
 P<sub>ac</sub>: axial load during uniform motion (N): formulas (13) and (16)  
 P<sub>ad</sub>: axial load during decelerating (N): formulas (15) and (18)

Table H-8 Sliding Resistance (f<sub>b</sub>) of a Single Block (Seal Resistance) unit: N

	high grade (H)	precision grade (P)
BG15	0.8	1.8
BG20	2.3	4.9
BG26	5.4	9.8
BG33	4.4	10.2
BG46	7.4	13.3
BG55	9	16

P<sub>ac</sub>: axial load rating during uniform motion (N)  
 P<sub>aa</sub>: axial load rating during accelerating (N)  
 P<sub>ad</sub>: axial load rating during decelerating (N)  
 μ: friction coefficient W: load applied to a block (N)  
 F: external force (load) applied to the axial direction (N)  
 f<sub>b</sub>: sliding resistance of a single block (N) (refer to Table H-8)  
 n: number of blocks of BG m: carrying mass (kg)  
 m<sub>b</sub>: mass of a block of BG (kg) (refer to P.H14~29)  
 α<sub>a</sub>: acceleration during accelerating (m/s<sup>2</sup>)  
 α<sub>d</sub>: acceleration during decelerating (m/s<sup>2</sup>)  
 g: acceleration of gravity

### BG15 –Without Top Cover–

A (1 long block)  
B (2 long blocks in close contact)

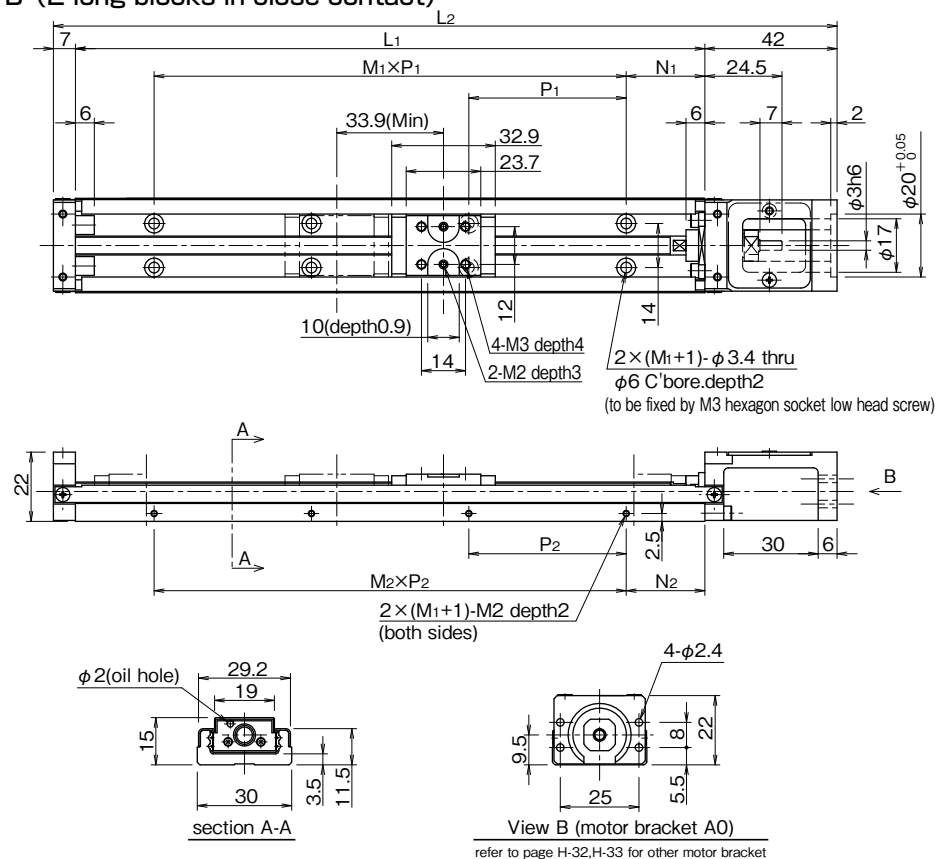

### BG15 –With Top Cover–

A (1 long block)  
B (2 long blocks in close contact)

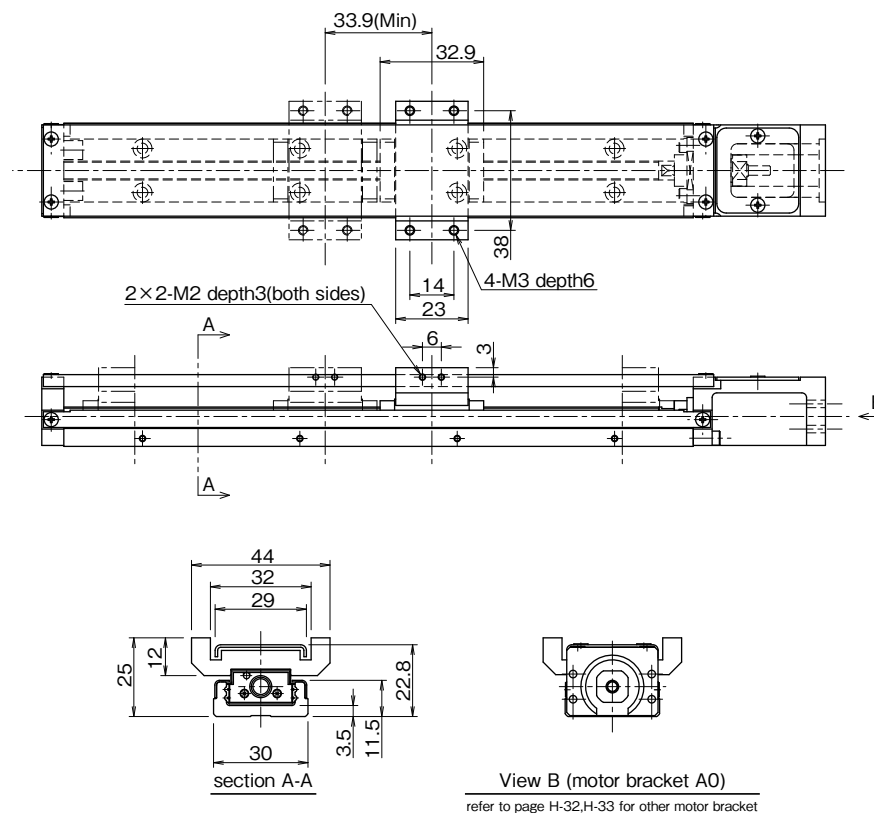

part number <sup>※3※4</sup>	stroke limit mm <sup>※1</sup>	dimensions mm						block mass kg <sup>※2</sup>		total mass kg	
		L <sub>1</sub>	L <sub>2</sub>	N <sub>1</sub>	M <sub>1</sub> ×P <sub>1</sub>	N <sub>2</sub>	M <sub>2</sub> ×P <sub>2</sub>	without top cover	with top cover	without top cover	with top cover
BG15□□ A-75	30	75	124	12.5	1×50	12.5	1×50	0.03	0.05	0.21	0.24
B	—	—	—	—	—	—	—	—	—	—	—
BG15□□ A-100	55	100	149	25	1×50	25	1×50	0.03	0.05	0.25	0.28
B	—	—	—	—	—	—	—	—	—	—	—
BG15□□ A-125	80	125	174	12.5	2×50	12.5	2×50	0.03	0.05	0.28	0.31
B	46							0.06	0.10	0.32	0.37
BG15□□ A-150	105	150	199	25	3×50	25	3×50	0.03	0.05	0.32	0.35
B	71							0.06	0.10	0.35	0.40
BG15□□ A-175	130	175	224	12.5	3×50	12.5	3×50	0.03	0.05	0.35	0.39
B	96							0.06	0.10	0.39	0.44
BG15□□ A-200	155	200	249	25	3×50	25	3×50	0.03	0.05	0.39	0.42
B	121							0.06	0.10	0.42	0.48

※1: Stroke limit is a drive distance between both ends of the dampers.  
 ※2: Mass stated "with top cover" includes mass of sub tables.  
 ※3: For B type (2 long blocks), drive block is located closest to motor bracket side.  
 ※4: □ is ball screw lead.

inertia (reference values) unit: kg · m<sup>2</sup>

part number	rail length mm	long block			
		without top cover		with top cover	
		A 1 block	B 2 block	A 1 block	B 2 block
BG1501	75	1.06 × 10 <sup>-7</sup>	—	1.07 × 10 <sup>-7</sup>	—
	100	1.31 × 10 <sup>-7</sup>	—	1.31 × 10 <sup>-7</sup>	—
	125	1.56 × 10 <sup>-7</sup>	1.56 × 10 <sup>-7</sup>	1.56 × 10 <sup>-7</sup>	1.58 × 10 <sup>-7</sup>
	150	1.80 × 10 <sup>-7</sup>	1.81 × 10 <sup>-7</sup>	1.81 × 10 <sup>-7</sup>	1.82 × 10 <sup>-7</sup>
	175	2.05 × 10 <sup>-7</sup>	2.06 × 10 <sup>-7</sup>	2.06 × 10 <sup>-7</sup>	2.07 × 10 <sup>-7</sup>
BG1502	200	2.30 × 10 <sup>-7</sup>	2.31 × 10 <sup>-7</sup>	2.31 × 10 <sup>-7</sup>	2.32 × 10 <sup>-7</sup>
	75	1.09 × 10 <sup>-7</sup>	—	1.11 × 10 <sup>-7</sup>	—
	100	1.33 × 10 <sup>-7</sup>	—	1.35 × 10 <sup>-7</sup>	—
	125	1.58 × 10 <sup>-7</sup>	1.62 × 10 <sup>-7</sup>	1.60 × 10 <sup>-7</sup>	1.66 × 10 <sup>-7</sup>
	150	1.83 × 10 <sup>-7</sup>	1.86 × 10 <sup>-7</sup>	1.85 × 10 <sup>-7</sup>	1.90 × 10 <sup>-7</sup>
	175	2.08 × 10 <sup>-7</sup>	2.11 × 10 <sup>-7</sup>	2.10 × 10 <sup>-7</sup>	2.15 × 10 <sup>-7</sup>
	200	2.33 × 10 <sup>-7</sup>	2.36 × 10 <sup>-7</sup>	2.35 × 10 <sup>-7</sup>	2.40 × 10 <sup>-7</sup>



### BG20 – Without Top Cover –

- A (1 long block)
- B (2 long blocks in close contact)

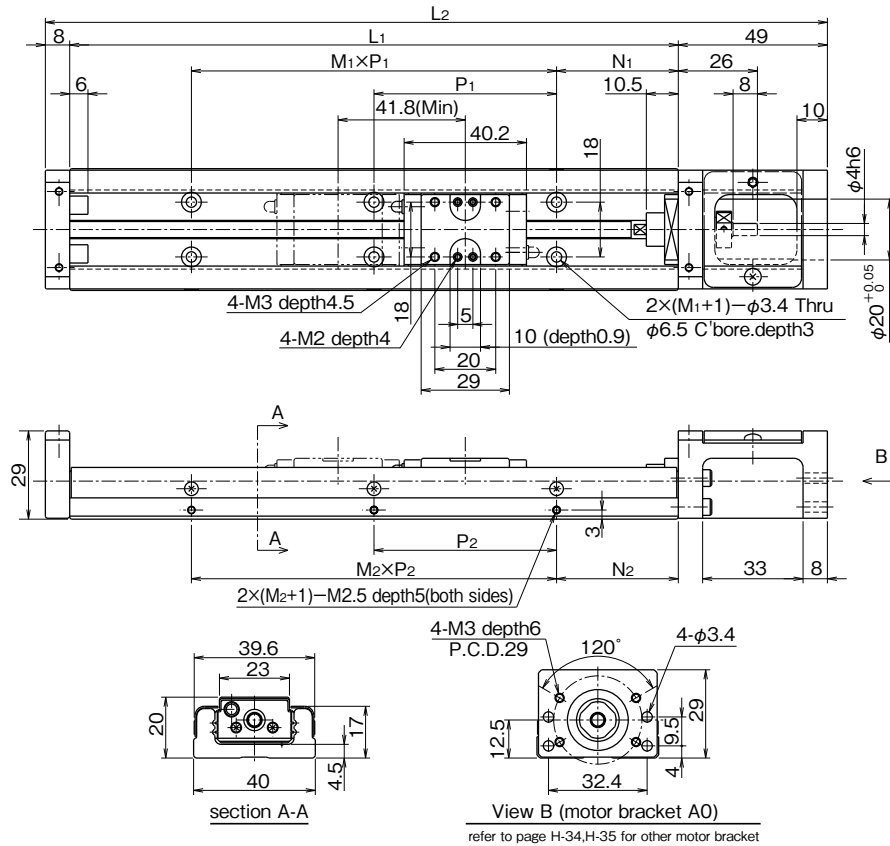

part number <sup>※3※4</sup>	stroke limit mm <sup>※1</sup>	dimensions mm		dimensions mm			block mass kg <sup>※2</sup>		total mass kg		
		L <sub>1</sub>	L <sub>2</sub>	N <sub>1</sub>	M <sub>1</sub> ×P <sub>1</sub>	N <sub>2</sub>	M <sub>2</sub> ×P <sub>2</sub>	without top cover	with top cover	without top cover	with top cover
BG20□□A-100	43	100	157	20	1×60	20	1×60	0.07	0.11	0.45	0.50
B	—	—	—	—	—	—	—	—	—	—	—
BG20□□A-150	93	150	207	15	2×60	15	2×60	0.07	0.11	0.58	0.63
B	51	—	—	—		—		—	—	0.14	0.22
BG20□□A-200	143	200	257	40	2×60	40	2×60	0.07	0.11	0.71	0.77
B	101	—	—	—		—		—	—	0.14	0.22

※1 : Stroke limit is a drive distance between both ends of the dampers.  
 ※2 : Mass stated "with top cover" includes mass of sub tables.  
 ※3 : For B type (2 long blocks), drive block is located closest to motor bracket side.  
 ※4 : □ is ball screw lead.

### BG20 – With Top Cover –

- A (1 long block)
- B (2 long blocks in close contact)

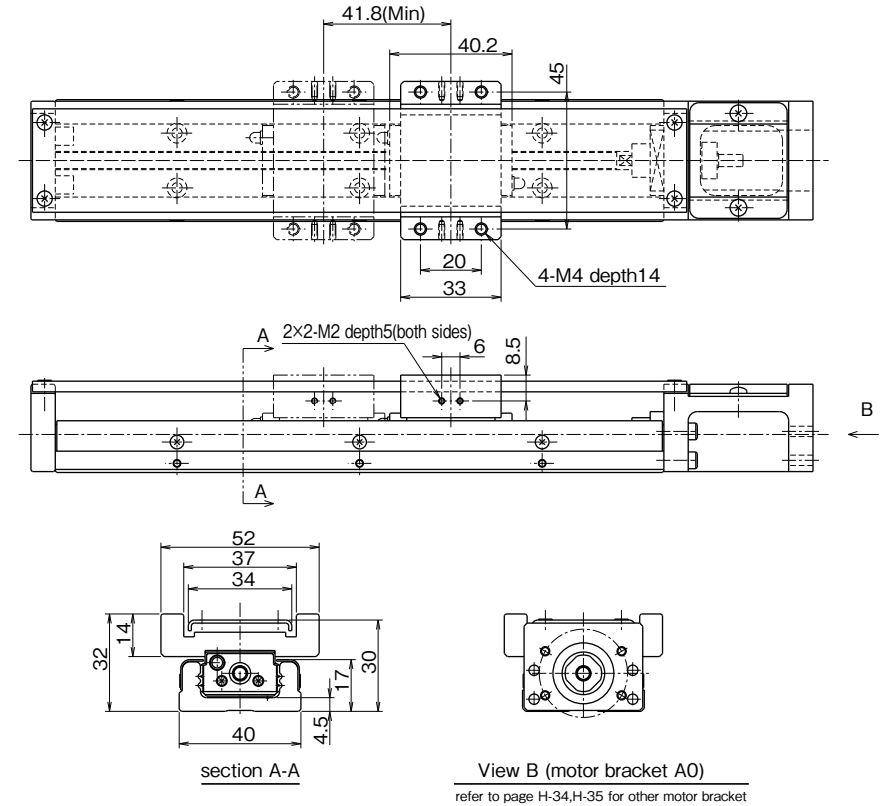

inertia (reference values) unit : kg · m<sup>2</sup>

part number	rail length mm	long block			
		without top cover		with top cover	
		A 1 block	B 2 block	A 1 block	B 2 block
BG2001	100	1.34 × 10 <sup>-7</sup>	—	1.35 × 10 <sup>-7</sup>	—
	150	1.83 × 10 <sup>-7</sup>	1.85 × 10 <sup>-7</sup>	1.84 × 10 <sup>-7</sup>	1.87 × 10 <sup>-7</sup>
	200	2.33 × 10 <sup>-7</sup>	2.35 × 10 <sup>-7</sup>	2.34 × 10 <sup>-7</sup>	2.37 × 10 <sup>-7</sup>
BG2005	100	1.76 × 10 <sup>-7</sup>	—	2.00 × 10 <sup>-7</sup>	—
	150	2.26 × 10 <sup>-7</sup>	2.70 × 10 <sup>-7</sup>	2.50 × 10 <sup>-7</sup>	3.18 × 10 <sup>-7</sup>
	200	2.76 × 10 <sup>-7</sup>	3.20 × 10 <sup>-7</sup>	3.00 × 10 <sup>-7</sup>	3.68 × 10 <sup>-7</sup>

**BG26 –Without Top Cover–**

A (1 long block)  
B (2 long blocks in close contact)

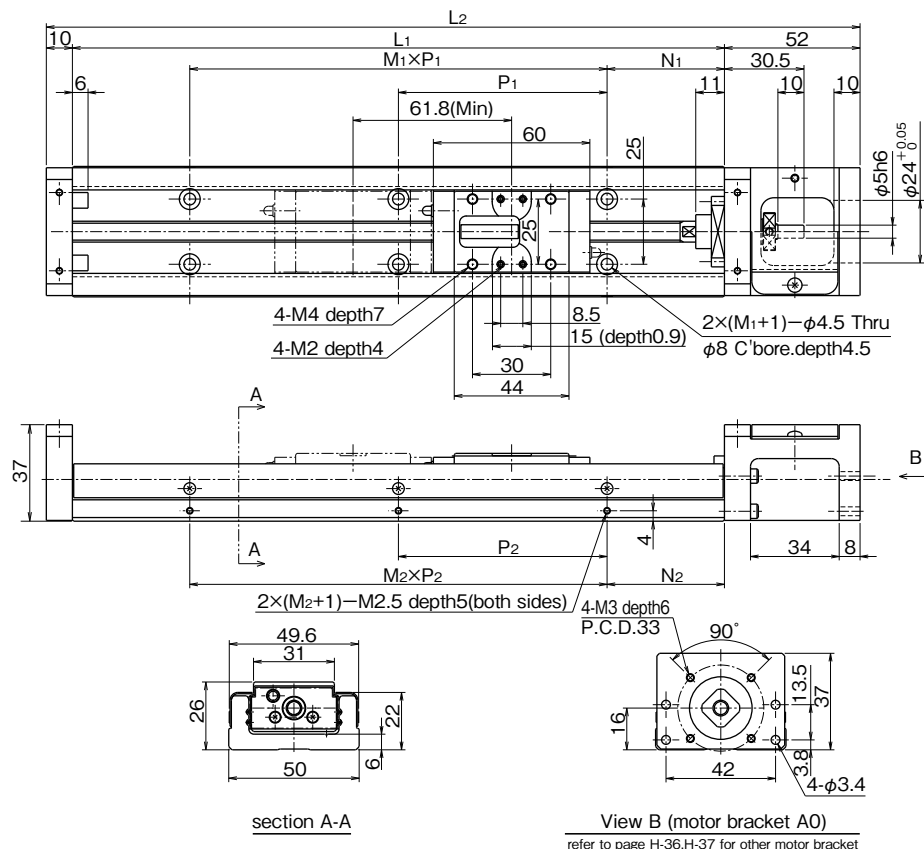

**BG26 –With Top Cover–**

A (1 long block)  
B (2 long blocks in close contact)

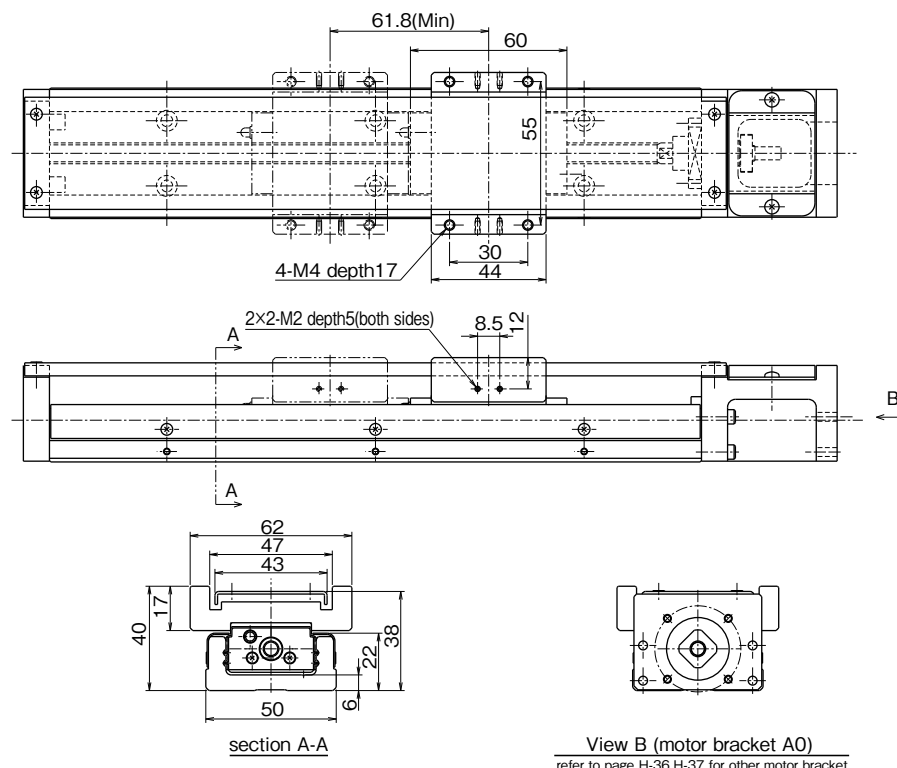

part number <sup>※3※4</sup>	stroke limit mm <sup>※1</sup>	dimensions mm						block mass kg <sup>※2</sup>		total mass kg	
		L <sub>1</sub>	L <sub>2</sub>	N <sub>1</sub>	M <sub>1</sub> ×P <sub>1</sub>	N <sub>2</sub>	M <sub>2</sub> ×P <sub>2</sub>	without top cover	with top cover	without top cover	with top cover
BG26□□A-150	73	150	212	35	1×80	35	1×80	0.17	0.24	0.93	1.07
B	—	—	—	—	—	—	—	—	—	—	—
BG26□□A-200	123	200	262	20	2×80	20	2×80	0.17	0.24	1.14	1.3
B	61	—	—	—				—	—	0.34	0.48
BG26□□A-250	173	250	312	45	45	45	45	0.17	0.24	1.36	1.53
B	111							—	—	—	—
BG26□□A-300	223	300	362	30	3×80	30	3×80	0.17	0.24	1.57	1.76
B	161							—	—	—	—

※1 : Stroke limit is a drive distance between both ends of the dampers.  
 ※2 : Mass stated "with top cover" includes mass of sub tables.  
 ※3 : For B type (2 long blocks), drive block is located closest to motor bracket side.  
 ※4 : □ is ball screw lead.

inertia (reference values) unit : kg · m<sup>2</sup>

part number	rail length mm	long block			
		without top cover		with top cover	
		A 1 block	B 2 block	A 1 block	B 2 block
BG2602	150	6.08 × 10 <sup>-7</sup>	—	6.16 × 10 <sup>-7</sup>	—
	200	7.65 × 10 <sup>-7</sup>	7.83 × 10 <sup>-7</sup>	7.73 × 10 <sup>-7</sup>	7.97 × 10 <sup>-7</sup>
	250	9.22 × 10 <sup>-7</sup>	9.39 × 10 <sup>-7</sup>	9.29 × 10 <sup>-7</sup>	9.54 × 10 <sup>-7</sup>
	300	1.08 × 10 <sup>-6</sup>	1.10 × 10 <sup>-6</sup>	1.09 × 10 <sup>-6</sup>	1.11 × 10 <sup>-6</sup>
BG2605	150	6.99 × 10 <sup>-7</sup>	—	7.44 × 10 <sup>-7</sup>	—
	200	8.56 × 10 <sup>-7</sup>	9.63 × 10 <sup>-7</sup>	9.01 × 10 <sup>-7</sup>	1.05 × 10 <sup>-6</sup>
	250	1.01 × 10 <sup>-6</sup>	1.12 × 10 <sup>-6</sup>	1.06 × 10 <sup>-6</sup>	1.21 × 10 <sup>-6</sup>
	300	1.17 × 10 <sup>-6</sup>	1.28 × 10 <sup>-6</sup>	1.21 × 10 <sup>-6</sup>	1.37 × 10 <sup>-6</sup>

### BG33 –Without Top Cover–

- A (1 long block)
- B (2 long blocks in close contact)

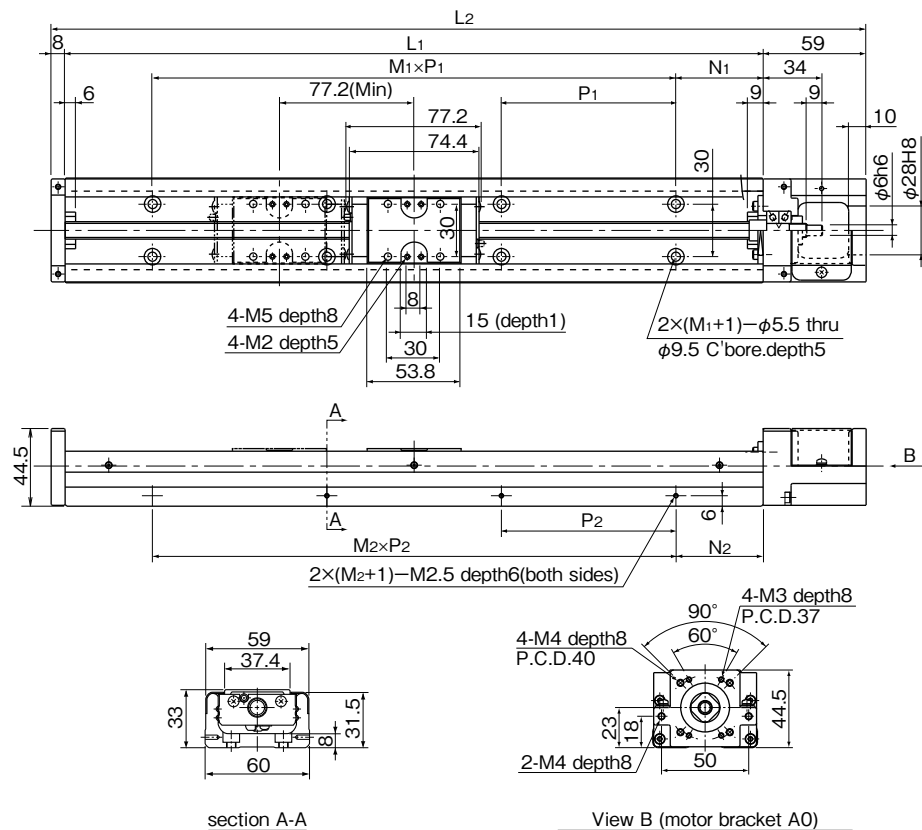

### BG33 –With Top Cover–

- A (1 long block)
- B (2 long blocks in close contact)

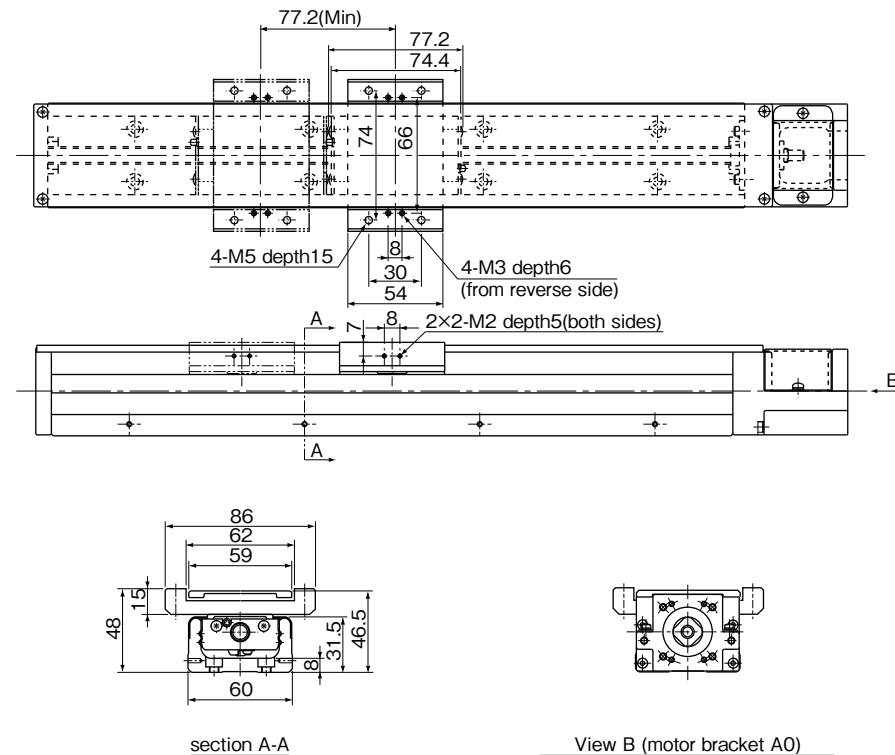

part number <sup>※3※4</sup>	stroke limit mm <sup>※1</sup>	dimensions mm					block mass kg <sup>※2</sup>		total mass kg		
		L <sub>1</sub>	L <sub>2</sub>	N <sub>1</sub>	M <sub>1</sub> ×P <sub>1</sub>	N <sub>2</sub>	M <sub>2</sub> ×P <sub>2</sub>	without top cover	with top cover	without top cover	with top cover
BG33□□A-150	60	150	217	25	1×100	25	1×100	0.3	0.4	1.6	1.8
B	—	—	—	—	—	—	—	—	—	—	—
BG33□□A-200	110	200	267	50	1×100	50	1×100	0.3	0.4	2	2.1
B	—	—	—	—	—	—	—	—	—	—	—
BG33□□A-300	210	300	367	50	2×100	50	2×100	0.3	0.4	2.6	2.8
B	133	—	—					0.6	0.8	2.9	3.2
BG33□□A-400	310	400	467	50	3×100	50	3×100	0.3	0.4	3.2	3.5
B	233	—	—					0.6	0.8	3.6	3.9
BG33□□A-500	410	500	567	50	4×100	50	4×100	0.3	0.4	3.9	4.2
B	333	—	—					0.6	0.8	4.2	4.6
BG33□□A-600	510	600	667	50	5×100	50	5×100	0.3	0.4	4.6	4.9
B	433	—	—					0.6	0.8	4.9	5.3

※1 : Stroke limit is a drive distance between both ends of the dampers.  
 ※2 : Mass stated "with top cover" includes mass of sub tables.  
 ※3 : For B type (2 long blocks), drive block is located closest to motor bracket side.  
 ※4 : □ is ball screw lead.

inertia (reference values) unit : kg · m<sup>2</sup>

part number	rail length mm	long block			
		without top cover		with top cover	
		A 1 block	B 2 block	A 1 block	B 2 block
BG3305	150	1.64×10 <sup>-6</sup>	—	1.71×10 <sup>-6</sup>	—
	200	2.02×10 <sup>-6</sup>	—	2.09×10 <sup>-6</sup>	—
	300	2.79×10 <sup>-6</sup>	2.99×10 <sup>-6</sup>	2.86×10 <sup>-6</sup>	3.13×10 <sup>-6</sup>
	400	3.55×10 <sup>-6</sup>	3.75×10 <sup>-6</sup>	3.62×10 <sup>-6</sup>	3.89×10 <sup>-6</sup>
	500	4.32×10 <sup>-6</sup>	4.52×10 <sup>-6</sup>	4.39×10 <sup>-6</sup>	4.66×10 <sup>-6</sup>
BG3310	600	5.08×10 <sup>-6</sup>	5.28×10 <sup>-6</sup>	5.15×10 <sup>-6</sup>	5.42×10 <sup>-6</sup>
	150	2.19×10 <sup>-6</sup>	—	2.47×10 <sup>-6</sup>	—
	200	2.57×10 <sup>-6</sup>	—	2.85×10 <sup>-6</sup>	—
	300	3.34×10 <sup>-6</sup>	4.14×10 <sup>-6</sup>	3.61×10 <sup>-6</sup>	4.69×10 <sup>-6</sup>
	400	4.10×10 <sup>-6</sup>	4.90×10 <sup>-6</sup>	4.38×10 <sup>-6</sup>	5.46×10 <sup>-6</sup>
BG3320	500	4.87×10 <sup>-6</sup>	5.67×10 <sup>-6</sup>	5.15×10 <sup>-6</sup>	6.22×10 <sup>-6</sup>
	600	5.63×10 <sup>-6</sup>	6.43×10 <sup>-6</sup>	5.91×10 <sup>-6</sup>	6.99×10 <sup>-6</sup>
	150	5.94×10 <sup>-6</sup>	—	7.06×10 <sup>-6</sup>	—
	200	6.74×10 <sup>-6</sup>	—	7.85×10 <sup>-6</sup>	—
	300	8.33×10 <sup>-6</sup>	1.15×10 <sup>-5</sup>	9.44×10 <sup>-6</sup>	1.38×10 <sup>-5</sup>
BG3320	400	9.91×10 <sup>-6</sup>	1.31×10 <sup>-5</sup>	1.10×10 <sup>-5</sup>	1.53×10 <sup>-5</sup>
	500	1.15×10 <sup>-5</sup>	1.47×10 <sup>-5</sup>	1.26×10 <sup>-5</sup>	1.69×10 <sup>-5</sup>
	600	1.31×10 <sup>-5</sup>	1.63×10 <sup>-5</sup>	1.42×10 <sup>-5</sup>	1.85×10 <sup>-5</sup>

### BG33 –Without Top Cover–

C (1 short block)

D (2 short blocks in close contact)

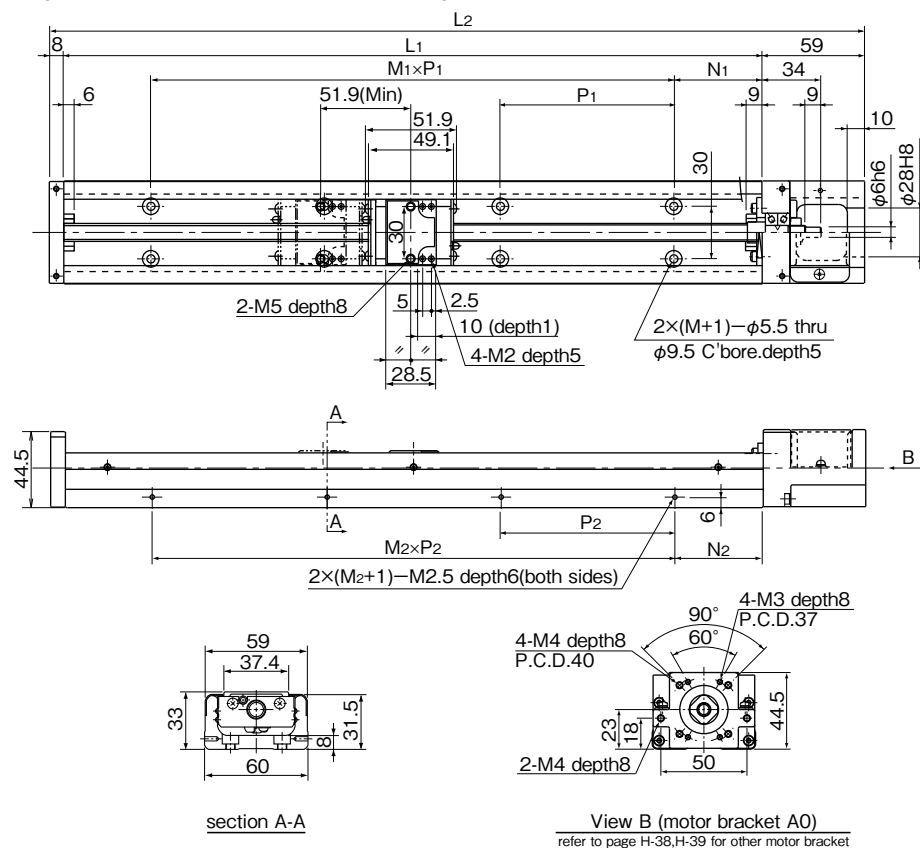

### BG33 –With Top Cover–

C (1 short block)

D (2 short blocks in close contact)

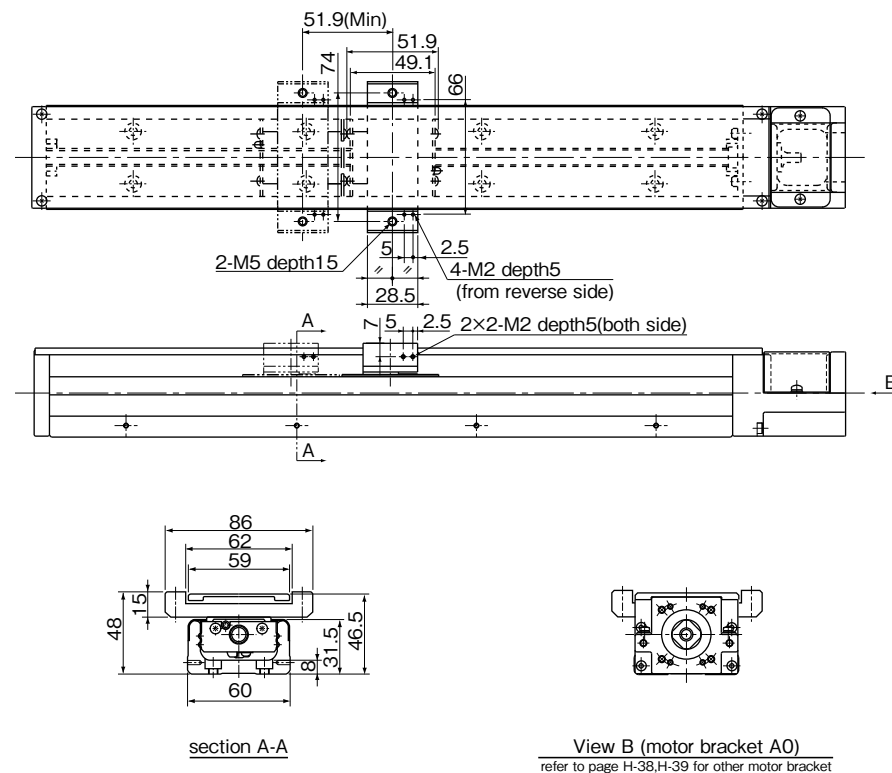

part number <sup>※3※4</sup>	stroke limit mm <sup>※1</sup>	dimensions mm					block mass kg <sup>※2</sup>		total mass kg		
		L <sub>1</sub>	L <sub>2</sub>	N <sub>1</sub>	M <sub>1</sub> ×P <sub>1</sub>	N <sub>2</sub>	M <sub>2</sub> ×P <sub>2</sub>	without top cover	with top cover	without top cover	with top cover
BG33□□C-150	85	150	217	25	1×100	25	1×100	0.15	0.2	1.5	1.6
	34							0.3	0.4	1.7	1.9
BG33□□C-200	135	200	267	50	2×100	50	2×100	0.15	0.2	1.8	2
	84							0.3	0.4	2	2.2
BG33□□C-300	235	300	367	50	3×100	50	3×100	0.15	0.2	2.5	2.6
	184							0.3	0.4	2.7	2.9
BG33□□C-400	335	400	467	50	4×100	50	4×100	0.15	0.2	3.1	3.3
	284							0.3	0.4	3.3	3.5
BG33□□C-500	435	500	567	50	5×100	50	5×100	0.15	0.2	3.8	4
	384							0.3	0.4	3.9	4.2
BG33□□C-600	535	600	667	50	5×100	50	5×100	0.15	0.2	4.4	4.7
	484							0.3	0.4	4.6	4.9

※1: Stroke limit is a drive distance between both ends of the dampers.  
 ※2: Mass stated "with top cover" includes mass of sub tables.  
 ※3: For D type (2 short blocks), drive block is located closest to motor bracket side.  
 ※4: □ is ball screw lead.  
 ※5: Ball screw lead of 20mm is not available for BG33 short block type.

inertia (reference values) unit: kg · m<sup>2</sup>

part number	rail length mm	short block			
		without top cover		with top cover	
		C	D	C	D
BG3305	150	1.56×10 <sup>-6</sup>	1.64×10 <sup>-6</sup>	1.60×10 <sup>-6</sup>	1.71×10 <sup>-6</sup>
	200	1.94×10 <sup>-6</sup>	2.03×10 <sup>-6</sup>	1.98×10 <sup>-6</sup>	2.10×10 <sup>-6</sup>
	300	2.71×10 <sup>-6</sup>	2.79×10 <sup>-6</sup>	2.75×10 <sup>-6</sup>	2.86×10 <sup>-6</sup>
	400	3.48×10 <sup>-6</sup>	3.56×10 <sup>-6</sup>	3.51×10 <sup>-6</sup>	3.63×10 <sup>-6</sup>
	500	4.24×10 <sup>-6</sup>	4.32×10 <sup>-6</sup>	4.28×10 <sup>-6</sup>	4.39×10 <sup>-6</sup>
	600	5.01×10 <sup>-6</sup>	5.09×10 <sup>-6</sup>	5.04×10 <sup>-6</sup>	5.16×10 <sup>-6</sup>
BG3310	150	1.88×10 <sup>-6</sup>	2.21×10 <sup>-6</sup>	2.02×10 <sup>-6</sup>	2.49×10 <sup>-6</sup>
	200	2.27×10 <sup>-6</sup>	2.59×10 <sup>-6</sup>	2.40×10 <sup>-6</sup>	2.87×10 <sup>-6</sup>
	300	3.03×10 <sup>-6</sup>	3.36×10 <sup>-6</sup>	3.17×10 <sup>-6</sup>	3.64×10 <sup>-6</sup>
	400	3.80×10 <sup>-6</sup>	4.12×10 <sup>-6</sup>	3.94×10 <sup>-6</sup>	4.40×10 <sup>-6</sup>
	500	4.56×10 <sup>-6</sup>	4.89×10 <sup>-6</sup>	4.70×10 <sup>-6</sup>	5.17×10 <sup>-6</sup>
	600	5.33×10 <sup>-6</sup>	5.65×10 <sup>-6</sup>	5.47×10 <sup>-6</sup>	5.93×10 <sup>-6</sup>

### BG46 –Without Top Cover–

- A (1 long block)
- B (2 long blocks in close contact)

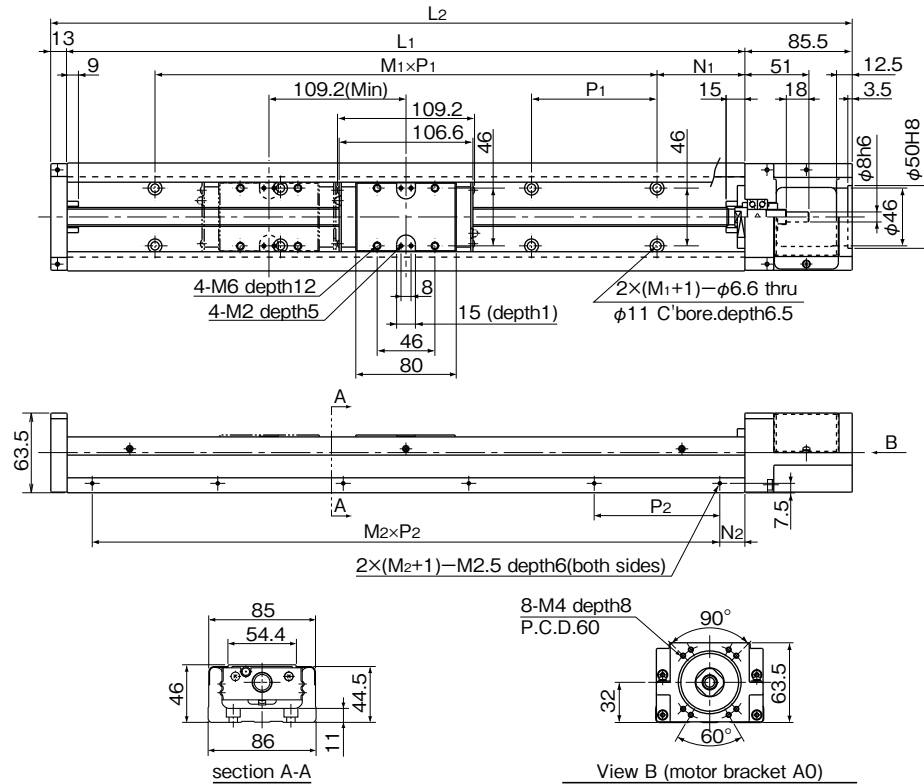

### BG46 –With Top Cover–

- A (1 long block)
- B (2 long blocks in close contact)

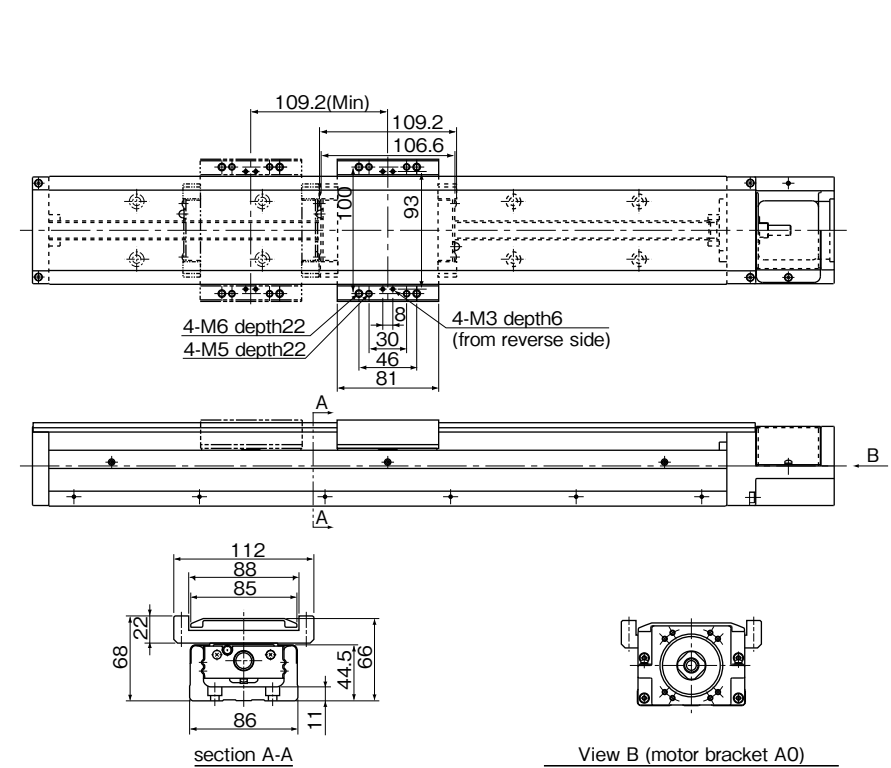

part number <sup>※3※4</sup>	stroke limit mm <sup>※1</sup>	dimensions mm		block mass kg <sup>※2</sup>		total mass kg			
		L <sub>1</sub>	L <sub>2</sub>	without top cover	with top cover	without top cover	with top cover		
BG46□□A-340	209	340	438.5	2×100	3×100	0.9	1.2	6.5	7
B	100					1.8	2.4	7.5	8
BG46□□A-440	309	440	538.5	3×100	4×100	0.9	1.2	8	8.5
B	200					1.8	2.4	8.5	9.5
BG46□□A-540	409	540	638.5	4×100	5×100	0.9	1.2	9	10
B	300					1.8	2.4	10	11
BG46□□A-640	509	640	738.5	5×100	6×100	0.9	1.2	10.5	11
B	400					1.8	2.4	11.5	12.5
BG46□□A-740	609	740	838.5	6×100	7×100	0.9	1.2	12	12.5
B	500					1.8	2.4	13	14
BG46□□A-840	709	840	938.5	7×100	8×100	0.9	1.2	13	14
B	600					1.8	2.4	14	15.5
BG46□□A-940	809	940	1,038.5	8×100	9×100	0.9	1.2	14.5	15.5
B	700					1.8	2.4	15.5	16.5
BG46□□A-1040	909	1,040	1,138.5	9×100	10×100	0.9	1.2	16	17
B	800					1.8	2.4	17	18
BG46□□A-1140	1,009	1,140	1,238.5	10×100	11×100	0.9	1.2	17.5	18.5
B	900					1.8	2.4	18	19.5
BG46□□A-1240	1,109	1,240	1,338.5	11×100	12×100	0.9	1.2	18.5	19.5
B	1,000					1.8	2.4	19.5	21

※1 : Stroke limit is a drive distance between both ends of the dampers.  
 ※2 : Mass stated "with top cover" includes mass of sub tables.  
 ※3 : For B type (2 long blocks), drive block is located closest to motor bracket side.  
 ※4 : □ is ball screw lead.

inertia (reference values) unit : kg · m<sup>2</sup>

part number	rail length mm	long block			
		without top cover		with top cover	
		A	B	A	B
BG4610	340	1.79 × 10 <sup>-5</sup>	2.02 × 10 <sup>-5</sup>	1.87 × 10 <sup>-5</sup>	2.17 × 10 <sup>-5</sup>
	440	2.18 × 10 <sup>-5</sup>	2.41 × 10 <sup>-5</sup>	2.25 × 10 <sup>-5</sup>	2.56 × 10 <sup>-5</sup>
	540	2.57 × 10 <sup>-5</sup>	2.79 × 10 <sup>-5</sup>	2.64 × 10 <sup>-5</sup>	2.95 × 10 <sup>-5</sup>
	640	2.95 × 10 <sup>-5</sup>	3.18 × 10 <sup>-5</sup>	3.03 × 10 <sup>-5</sup>	3.33 × 10 <sup>-5</sup>
	740	3.34 × 10 <sup>-5</sup>	3.57 × 10 <sup>-5</sup>	3.42 × 10 <sup>-5</sup>	3.72 × 10 <sup>-5</sup>
	840	3.73 × 10 <sup>-5</sup>	3.96 × 10 <sup>-5</sup>	3.80 × 10 <sup>-5</sup>	4.11 × 10 <sup>-5</sup>
	940	4.12 × 10 <sup>-5</sup>	4.35 × 10 <sup>-5</sup>	4.19 × 10 <sup>-5</sup>	4.50 × 10 <sup>-5</sup>
	1,040	4.50 × 10 <sup>-5</sup>	4.74 × 10 <sup>-5</sup>	4.58 × 10 <sup>-5</sup>	4.88 × 10 <sup>-5</sup>
	1,140	4.89 × 10 <sup>-5</sup>	5.12 × 10 <sup>-5</sup>	4.97 × 10 <sup>-5</sup>	5.27 × 10 <sup>-5</sup>
	1,240	5.28 × 10 <sup>-5</sup>	5.51 × 10 <sup>-5</sup>	5.35 × 10 <sup>-5</sup>	5.66 × 10 <sup>-5</sup>
BG4620	340	2.47 × 10 <sup>-5</sup>	3.39 × 10 <sup>-5</sup>	2.78 × 10 <sup>-5</sup>	3.99 × 10 <sup>-5</sup>
	440	2.86 × 10 <sup>-5</sup>	3.77 × 10 <sup>-5</sup>	3.17 × 10 <sup>-5</sup>	4.38 × 10 <sup>-5</sup>
	540	3.25 × 10 <sup>-5</sup>	4.16 × 10 <sup>-5</sup>	3.55 × 10 <sup>-5</sup>	4.77 × 10 <sup>-5</sup>
	640	3.63 × 10 <sup>-5</sup>	4.55 × 10 <sup>-5</sup>	3.94 × 10 <sup>-5</sup>	5.16 × 10 <sup>-5</sup>
	740	4.03 × 10 <sup>-5</sup>	4.94 × 10 <sup>-5</sup>	4.33 × 10 <sup>-5</sup>	5.55 × 10 <sup>-5</sup>
	840	4.41 × 10 <sup>-5</sup>	5.34 × 10 <sup>-5</sup>	4.71 × 10 <sup>-5</sup>	5.93 × 10 <sup>-5</sup>
	940	4.80 × 10 <sup>-5</sup>	5.72 × 10 <sup>-5</sup>	5.09 × 10 <sup>-5</sup>	6.32 × 10 <sup>-5</sup>
	1,040	5.19 × 10 <sup>-5</sup>	6.11 × 10 <sup>-5</sup>	5.48 × 10 <sup>-5</sup>	6.71 × 10 <sup>-5</sup>
	1,140	5.57 × 10 <sup>-5</sup>	6.50 × 10 <sup>-5</sup>	5.87 × 10 <sup>-5</sup>	7.09 × 10 <sup>-5</sup>
	1,240	5.96 × 10 <sup>-5</sup>	6.89 × 10 <sup>-5</sup>	6.26 × 10 <sup>-5</sup>	7.48 × 10 <sup>-5</sup>

View B (motor bracket A0)  
 refer to page H-40,H-41 for other motor bracket

**BG46 –Without Top Cover–**

C (1 short block)  
D (2 short blocks in close contact)

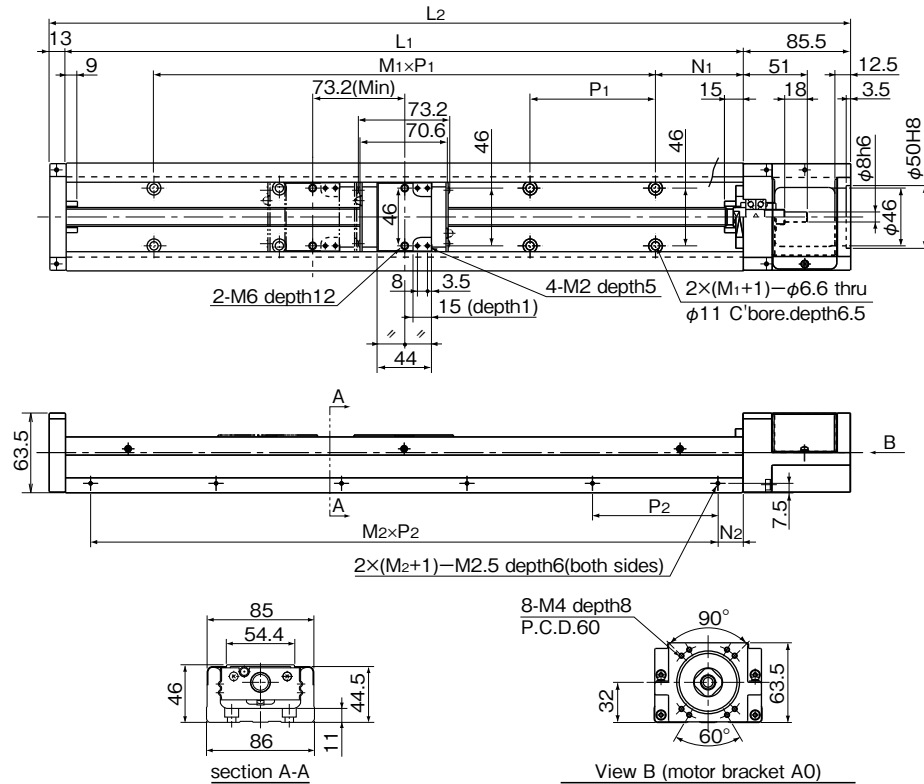

part number <sup>※3※4</sup>	stroke limit mm <sup>※1</sup>	dimensions mm		block mass kg <sup>※2</sup>		total mass kg					
		L <sub>1</sub>	L <sub>2</sub>	without top cover	with top cover	without top cover	with top cover				
BG46□□C-340	245	340	438.5	70	20	2×100	3×100	0.5	0.7	6	6.5
	D						172	1	1.4	6.5	7
BG46□□C-440	345	440	538.5			3×100	4×100	0.5	0.7	7.5	8
	D						272	1	1.4	8	8.5
BG46□□C-540	445	540	638.5			4×100	5×100	0.5	0.7	8.5	9.5
	D						372	1	1.4	9.5	10
BG46□□C-640	545	640	738.5			5×100	6×100	0.5	0.7	10	10.5
	D						472	1	1.4	10.5	11.5
BG46□□C-740	645	740	838.5			6×100	7×100	0.5	0.7	11.5	12
	D						572	1	1.4	12	13
BG46□□C-840	745	840	938.5			7×100	8×100	0.5	0.7	13	13.5
	D						672	1	1.4	13.5	14
BG46□□C-940	845	940	1,038.5	8×100	9×100	0.5	0.7	14	15		
	D				772	1	1.4	14.5	15.5		
BG46□□C-1040	945	1,040	1,138.5	9×100	10×100	0.5	0.7	15.5	16.5		
	D				872	1	1.4	16	17		
BG46□□C-1140	1,045	1,140	1,238.5	10×100	11×100	0.5	0.7	17	18		
	D				972	1	1.4	17.5	18.5		
BG46□□C-1240	1,145	1,240	1,338.5	11×100	12×100	0.5	0.7	18.5	19		
	D				1,072	1	1.4	19	20		

※1 : Stroke limit is a drive distance between both ends of the dampers.  
 ※2 : Mass stated "with top cover" includes mass of sub tables.  
 ※3 : For D type (2 short blocks), drive block is located closest to motor bracket side.  
 ※4 : □ is ball screw lead.

**BG46 –With Top Cover–**

C (1 short block)  
D (2 short blocks in close contact)

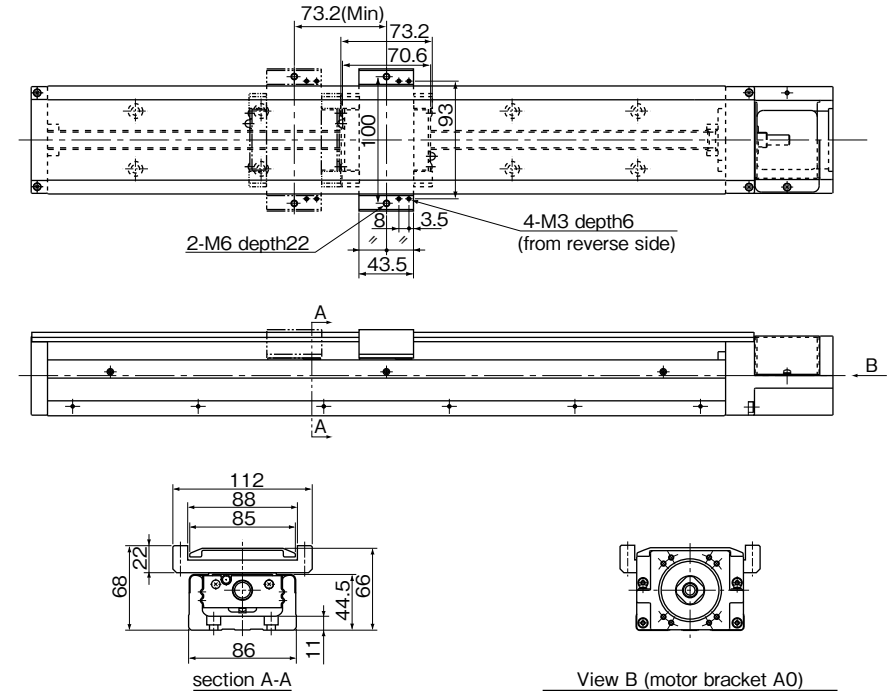

inertia (reference values) unit : kg · m<sup>2</sup>

part number	rail length mm	short block				
		without top cover		with top cover		
		C 1 block	D 2 block	C 1 block	D 2 block	
BG4610	340	1.69 × 10 <sup>-5</sup>	1.82 × 10 <sup>-5</sup>	1.74 × 10 <sup>-5</sup>	1.92 × 10 <sup>-5</sup>	
	440	2.08 × 10 <sup>-5</sup>	2.20 × 10 <sup>-5</sup>	2.13 × 10 <sup>-5</sup>	2.31 × 10 <sup>-5</sup>	
	540	2.46 × 10 <sup>-5</sup>	2.59 × 10 <sup>-5</sup>	2.52 × 10 <sup>-5</sup>	2.69 × 10 <sup>-5</sup>	
	640	2.85 × 10 <sup>-5</sup>	2.98 × 10 <sup>-5</sup>	2.90 × 10 <sup>-5</sup>	3.08 × 10 <sup>-5</sup>	
	740	3.24 × 10 <sup>-5</sup>	3.37 × 10 <sup>-5</sup>	3.29 × 10 <sup>-5</sup>	3.47 × 10 <sup>-5</sup>	
	840	3.63 × 10 <sup>-5</sup>	3.75 × 10 <sup>-5</sup>	3.67 × 10 <sup>-5</sup>	3.83 × 10 <sup>-5</sup>	
	940	4.02 × 10 <sup>-5</sup>	4.14 × 10 <sup>-5</sup>	4.06 × 10 <sup>-5</sup>	4.22 × 10 <sup>-5</sup>	
	1,040	4.41 × 10 <sup>-5</sup>	4.53 × 10 <sup>-5</sup>	4.44 × 10 <sup>-5</sup>	4.61 × 10 <sup>-5</sup>	
	1,140	4.79 × 10 <sup>-5</sup>	4.92 × 10 <sup>-5</sup>	4.83 × 10 <sup>-5</sup>	4.99 × 10 <sup>-5</sup>	
	1,240	5.18 × 10 <sup>-5</sup>	5.30 × 10 <sup>-5</sup>	5.22 × 10 <sup>-5</sup>	5.38 × 10 <sup>-5</sup>	
	BG4620	340	2.07 × 10 <sup>-5</sup>	2.58 × 10 <sup>-5</sup>	2.27 × 10 <sup>-5</sup>	2.98 × 10 <sup>-5</sup>
		440	2.46 × 10 <sup>-5</sup>	2.96 × 10 <sup>-5</sup>	2.66 × 10 <sup>-5</sup>	3.37 × 10 <sup>-5</sup>
540		2.84 × 10 <sup>-5</sup>	3.35 × 10 <sup>-5</sup>	3.05 × 10 <sup>-5</sup>	3.76 × 10 <sup>-5</sup>	
640		3.23 × 10 <sup>-5</sup>	3.74 × 10 <sup>-5</sup>	3.44 × 10 <sup>-5</sup>	4.14 × 10 <sup>-5</sup>	
740		3.62 × 10 <sup>-5</sup>	4.13 × 10 <sup>-5</sup>	3.82 × 10 <sup>-5</sup>	4.53 × 10 <sup>-5</sup>	
840		4.02 × 10 <sup>-5</sup>	4.51 × 10 <sup>-5</sup>	4.17 × 10 <sup>-5</sup>	4.82 × 10 <sup>-5</sup>	
940		4.41 × 10 <sup>-5</sup>	4.90 × 10 <sup>-5</sup>	4.56 × 10 <sup>-5</sup>	5.21 × 10 <sup>-5</sup>	
1,040		4.80 × 10 <sup>-5</sup>	5.29 × 10 <sup>-5</sup>	4.95 × 10 <sup>-5</sup>	5.59 × 10 <sup>-5</sup>	
1,140		5.18 × 10 <sup>-5</sup>	5.68 × 10 <sup>-5</sup>	5.34 × 10 <sup>-5</sup>	5.98 × 10 <sup>-5</sup>	
1,240		5.57 × 10 <sup>-5</sup>	6.06 × 10 <sup>-5</sup>	5.72 × 10 <sup>-5</sup>	6.37 × 10 <sup>-5</sup>	

View B (motor bracket A0)  
refer to page H-40,H-41 for other motor bracket

### BG55 –Without Top Cover–

- A (1 long block)
- B (2 long blocks in close contact)

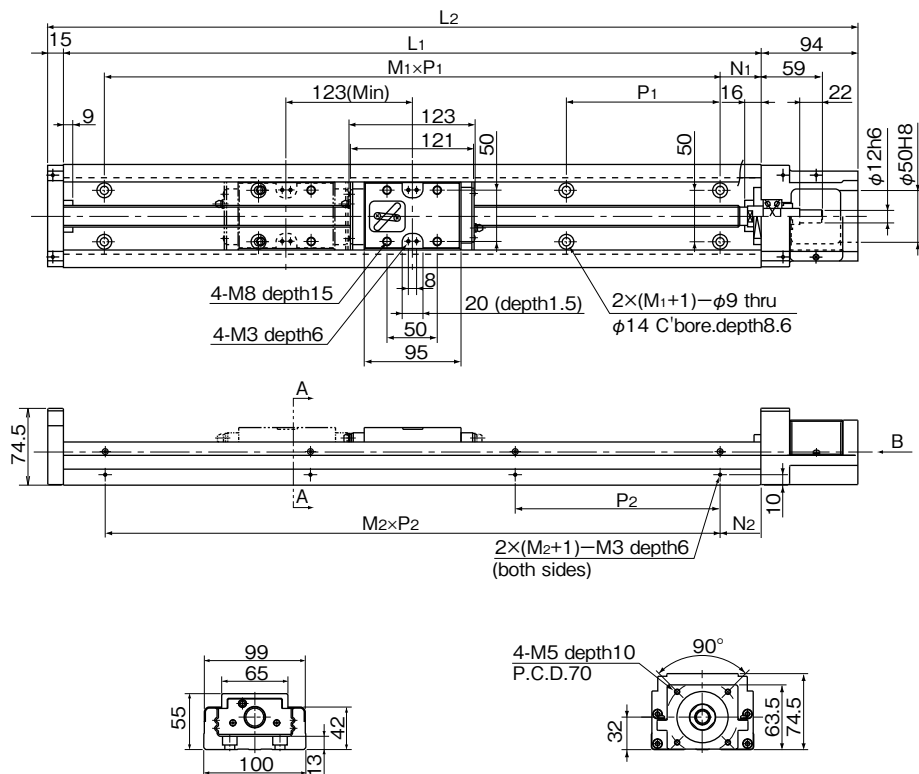

section A-A

View B (motor bracket A0)  
refer to page H-42,H-43 for other motor bracket

### BG55 –With Top Cover–

- A (1 long block)
- B (2 long blocks in close contact)

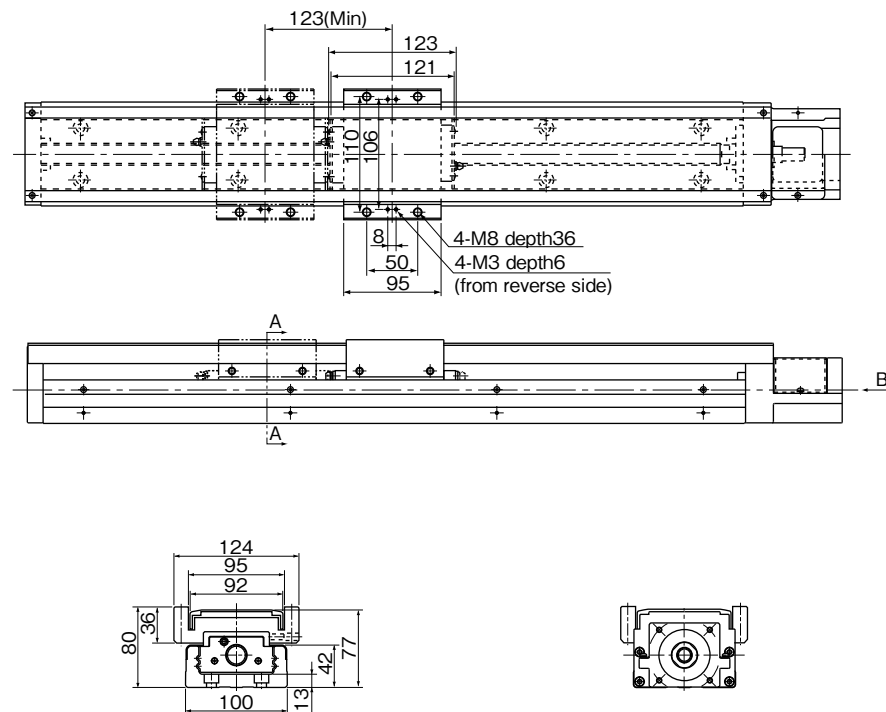

section A-A

View B (motor bracket A0)  
refer to page H-42,H-43 for other motor bracket

part number <sup>※3※4</sup>	stroke limit mm <sup>※1</sup>	dimensions mm					block mass kg <sup>※2</sup>		total mass kg		
		L <sub>1</sub>	L <sub>2</sub>	N <sub>1</sub>	M <sub>1</sub> ×P <sub>1</sub>	N <sub>2</sub>	M <sub>2</sub> ×P <sub>2</sub>	without top cover	with top cover	without top cover	with top cover
BG55□□A-980	834	980	1,089	40	6×150	90	4×200	1.7	2.3	20	21
	711							3.4	4.6	22	24
BG55□□A-1080	934	1,080	1,189	15	7×150	40	5×200	1.7	2.3	22	23
	811							3.4	4.6	24	26
BG55□□A-1180	1,034	1,180	1,289	65	90	6×200	6×200	1.7	2.3	23	25
	911							3.4	4.6	25	27
BG55□□A-1280	1,134	1,280	1,389	40	8×150	40	6×200	1.7	2.3	25	27
	1,011							3.4	4.6	27	29
BG55□□A-1380	1,234	1,380	1,489	15	9×150	90	6×200	1.7	2.3	27	29
	1,111							3.4	4.6	29	31

※1: Stroke limit is a drive distance between both ends of the dampers.  
 ※2: Mass stated "with top cover" includes mass of sub tables.  
 ※3: For B type (2 long blocks), drive block is located closest to motor bracket side.  
 ※4: □ is ball screw lead.

inertia (reference values) unit: kg · m<sup>2</sup>

part number	rail length mm	long block			
		without top cover		with top cover	
		A 1 block	B 2 block	A 1 block	B 2 block
BG5520	980	1.46 × 10 <sup>-4</sup>	1.64 × 10 <sup>-4</sup>	1.52 × 10 <sup>-4</sup>	1.76 × 10 <sup>-4</sup>
	1,080	1.59 × 10 <sup>-4</sup>	1.76 × 10 <sup>-4</sup>	1.65 × 10 <sup>-4</sup>	1.88 × 10 <sup>-4</sup>
	1,180	1.71 × 10 <sup>-4</sup>	1.88 × 10 <sup>-4</sup>	1.77 × 10 <sup>-4</sup>	2.00 × 10 <sup>-4</sup>
	1,280	1.83 × 10 <sup>-4</sup>	2.00 × 10 <sup>-4</sup>	1.89 × 10 <sup>-4</sup>	2.12 × 10 <sup>-4</sup>
	1,380	1.95 × 10 <sup>-4</sup>	2.13 × 10 <sup>-4</sup>	2.01 × 10 <sup>-4</sup>	2.25 × 10 <sup>-4</sup>

MOTOR BRACKET CONFIGURATIONS & APPLICABLE MOTORS

NB provides optional motor brackets to easily install most popular motors.

Table H-9 (1) Applicable Motors

Applicable motors			Output flange	BG15	BG20	BG26	BG33	BG46	BG55		
				P.H-32 ~33	P.H-34 ~35	P.H-36 ~37	P.H-38 ~39	P.H-40 ~41	P.H-42 ~43		
AC Servo motor	Panasonic	E	MUMA5A	50W	-	AA	AA	B2	-	-	
			MUMA01	100W	-	AA	AA	B2	-	-	
			MUMA02	200W	-	-	-	A7	A2	-	
			MUMA04	400W	-	-	-	-	-	-	
		A4	MSMD5A	50W	-	A3	A3	A2	C0	-	
			MSMD01	100W	-	-	-	A7	A2	-	
			MSMD02	200W	-	-	-	-	-	-	
			MSMD04	400W	-	-	-	-	A3	A2	
		A5	MSME5A	50W	-	A3	A3	A2	C0	-	
	MSME01		100W	-	-	-	A7	A2	-		
	MSME02		200W	-	-	-	-	-	-		
	MSME04		400W	-	-	-	-	A3	A2		
	MSME08		750W	-	-	-	-	-	-		
	YASKAWA ELECTRIC	MITSUBISHI ELECTRIC	J2-Jr	HC-AQ0135	10W	A1	A8	A8	-	-	-
				HC-AQ0235	20W	-	-	-	-	-	-
				HC-AQ0335	30W	-	-	-	-	-	-
			J4	HG-KR(MR)053	50W	-	A1	A1	A1	B0	-
				HG-KR(MR)13	100W	-	-	-	A6	A1	A0
HG-KR(MR)23				200W	-	-	-	-	A4	A1	
HG-KR(MR)43				400W	-	-	-	-	-	-	
J3			HF-KP(MP)053	50W	-	A1	A1	A1	B0	-	
			HF-KP(MP)13	100W	-	-	-	A6	A1	A0	
		HF-KP(MP)23	200W	-	-	-	-	A4	A1		
		HF-KP(MP)43	400W	-	-	-	-	-	-		
		HF-KP(MP)73	750W	-	-	-	-	-	-		
Σ-V		mini	SGMMV-A1	10W	A2	A9	A9	-	-	-	
			SGMMV-A2	20W	-	-	-	-	-	-	
			SGMMV-A3	30W	-	-	-	-	-	-	
		Σ-V	SGMJV(SGMAV)-A5	50W	-	A1	A1	A1	B0	-	
			SGMJV(SGMAV)-01	100W	-	-	-	A6	A1	A0	
			SGMAV-C2	150W	-	-	-	-	-	-	
	SGMJV(SGMAV)-02		200W	-	-	-	-	A4	A1		
	SGMJV(SGMAV)-04		400W	-	-	-	-	-	-		
	SGMAV-06		550W	-	-	-	-	-	-		
Σ-III	SGMAS-A5	50W	-	A1	A1	A1	B0	-			
	SGMAS-01	100W	-	-	-	A6	A1	A0			
	SGMAS-C2	150W	-	-	-	-	-	-			
	SGMAS-02	200W	-	-	-	-	A4	A1			
	SGMAS-04	400W	-	-	-	-	-	-			
	SGMAS-08	750W	-	-	-	-	-	-			

Table H-9 (2) Applicable Motors

Applicable motors			Output flange	BG15	BG20	BG26	BG33	BG46	BG55	
				P.H-32 ~33	P.H-34 ~35	P.H-36 ~37	P.H-38 ~39	P.H-40 ~41	P.H-42 ~43	
AC Servo motor	SANYO DENKI	Q	Q1AA04003D	30W	-	A1	A1	A1	B0	-
			Q1AA04005D	50W	-	-	-	A6	A1	A0
			Q1AA04010D	100W	-	-	-	-	-	-
			Q1AA06020D	200W	-	-	-	-	-	-
			Q1AA06040D	400W	-	-	-	-	-	-
		Q1AA07075D	750W	-	-	-	-	-	-	
		R	R2AA04005	50W	-	A1	A1	A1	B0	-
			R2AA04010	100W	-	-	-	A6	A1	A0
			R2AA06020	200W	-	-	-	-	-	-
	R2AA06040		400W	-	-	-	-	-	-	
	ORIENTAL MOTOR	α step	ASC3*	□28	A3	A6	A6	-	-	-
			AS46,ASC46	□42	-	A5	A5	B1	-	-
			AS6*,ASC66	□60	-	-	-	A8	D0	-
			AS9*	□85	-	-	-	-	D1	A4
			AR4,ARL4	□42	-	A5	A5	B1	-	-
			AR6,ARL6	□60	-	-	-	-	D0	-
		5 phase motor	AR9,ARL9	□85	-	-	-	-	D1	A4
			CSK51,CRK51	□20	A5	-	-	-	-	-
CSK52,CRK52			□28	A3	A6	A6	-	-	-	
CSK54,CRK54	□42		-	A5	A5	B1	-	-		
CSK56,CRK56	□60		-	-	-	A8	D0	-		
CSK59	□85		-	-	-	-	D1	A4		
RK54	□42		-	A5	A5	B1	-	-		
RK56	□60		-	-	-	A8	D0	-		
RK59	□85		-	-	-	-	D1	A4		
2 phase motor	RKS54	□42	-	A5	A5	B1	-	-		
	RKS56	□60	-	-	-	-	D0	-		
	RKS59	□85	-	-	-	-	D1	A4		
SANYO DENKI	5 phase motor	PK22,CSK22	□28	A3	A6	A6	-	-	-	
		PK24,CSK24,UMK24	□42	-	A5	A5	B1	-	-	
		PK26,CSK26,UMK26	□60	-	-	-	A5	-	-	
		SH528	□28	A3	A6	A6	-	-	-	
	5 phase motor	103H(F,M)55	□42	-	A5	A5	B1	-	-	
		103H(F,M)785	□60	-	-	-	A8	D0	-	
		103H(F,M)858	□85	-	-	-	-	D1	A5	
		*K-S52*	□28	A4	-	-	-	-	-	
		*K-S54*	□42	-	A5	A5	B1	-	-	
TECHNO DRIVE	5 phase motor	*K-S(M)56*	□60	-	-	-	A8	D0	-	
		*K-M(G)59*	□85	-	-	-	-	D1	A5	

NB can provide other types of motor brackets. Please contact NB for details.



# BG15

Figures inside ( ) indicates mass of the motor mount adapter plate.

## A0

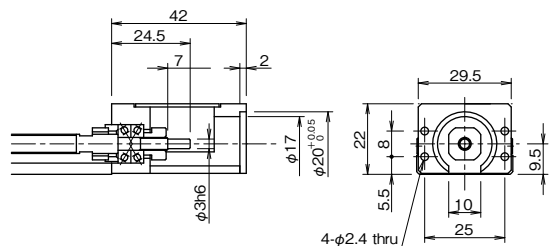

## A1 (Mass: 9g)

Recommended Coupling: XBW-15C2(Nabeya Bi-tech Kaisha)  
SFC-005DA2(Miki Pully Co., Ltd.)

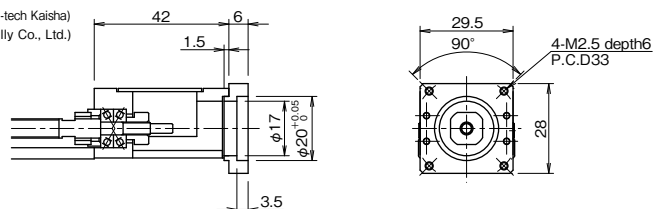

## A2 (Mass: 8g)

Recommended Coupling: LAD-15C(Sakai Manufacturing Co., Ltd.)  
XBW-15C2(Nabeya Bi-tech Kaisha)  
SFC-005DA2(Miki Pully Co., Ltd.)

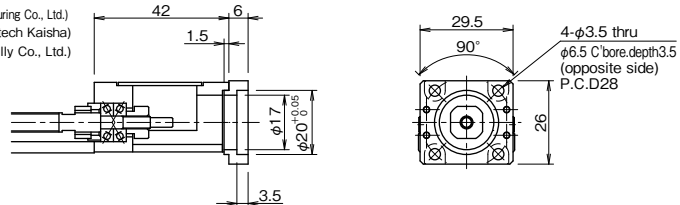

## A3 (Mass: 9g)

Recommended Coupling: LAD-15C(Sakai Manufacturing Co., Ltd.)  
XBW-15C2(Nabeya Bi-tech Kaisha)  
SFC-005DA2(Miki Pully Co., Ltd.)

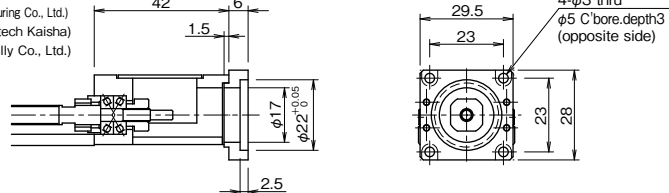

## A4 (Mass: 8g)

Recommended Coupling: LAD-15C(Sakai Manufacturing Co., Ltd.)  
XBW-15C2(Nabeya Bi-tech Kaisha)  
SFC-005DA2(Miki Pully Co., Ltd.)

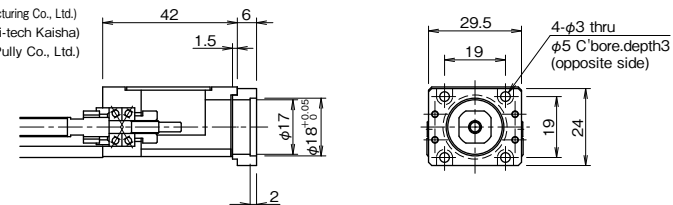

## A5 (Mass: 4g)

Recommended Coupling: XBW-15C2(Nabeya Bi-tech Kaisha)

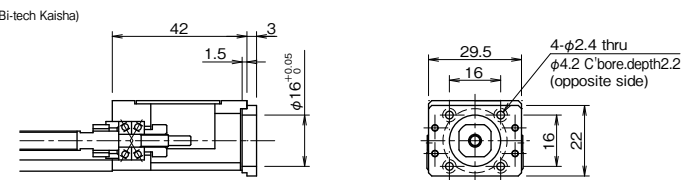

## A6 (Mass: 4g)

Recommended Coupling: XBW-15C2(Nabeya Bi-tech Kaisha)

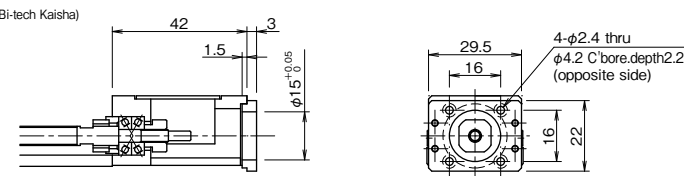

## A7 (Mass: 11g)

Recommended Coupling: LAD-15C(Sakai Manufacturing Co., Ltd.)  
XBW-15C2(Nabeya Bi-tech Kaisha)

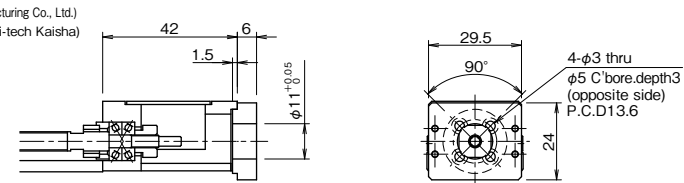

Attach the motor to the motor mount adapter plate first.

# BG20

Figures inside ( ) indicates mass of the motor mount adapter plate.

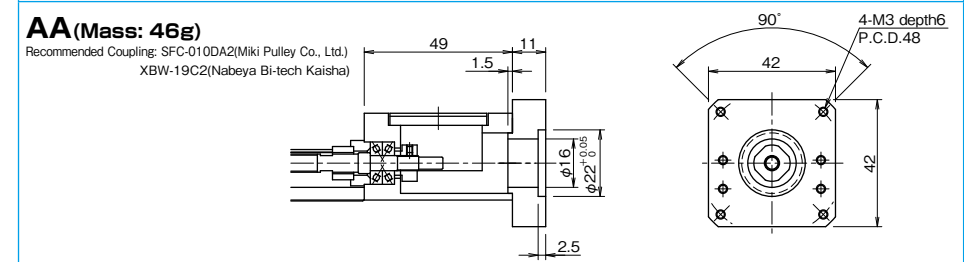
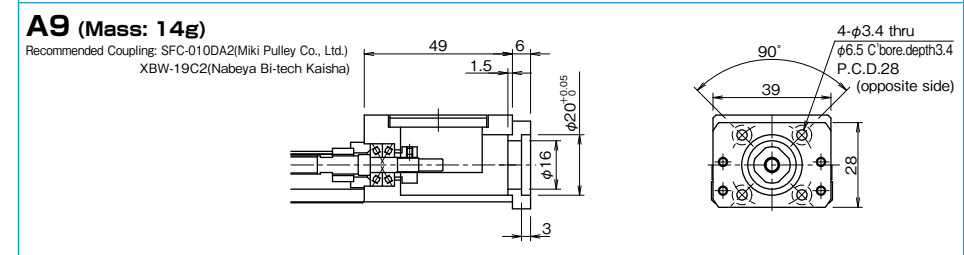
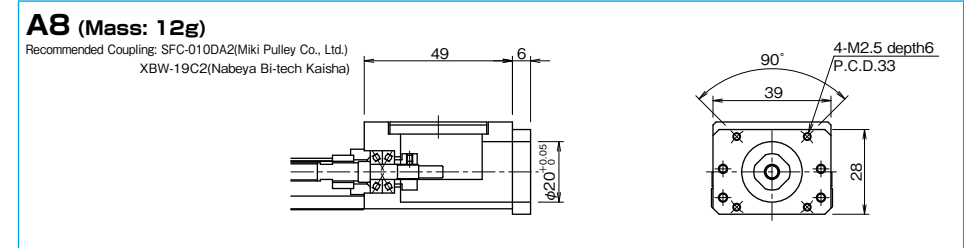
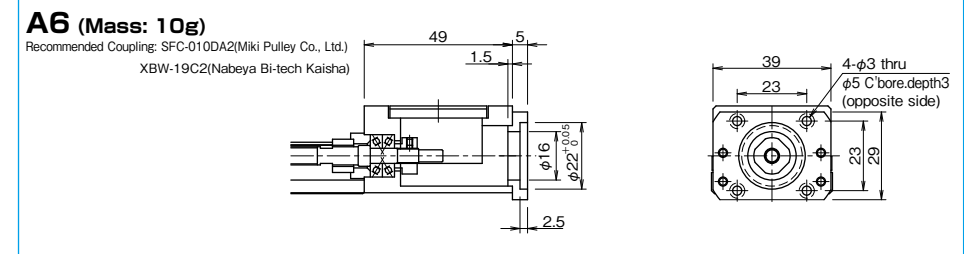
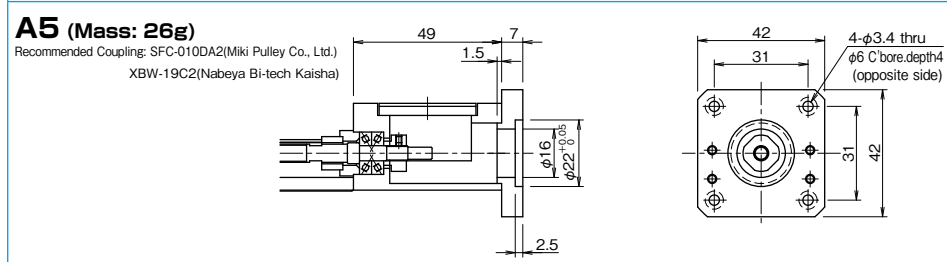
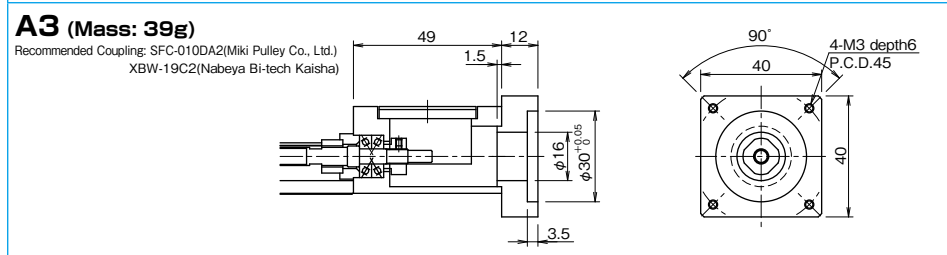
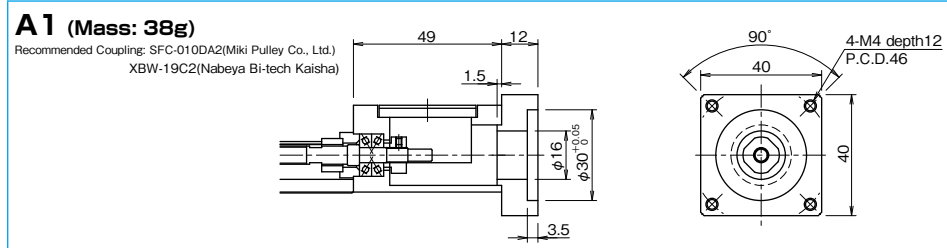
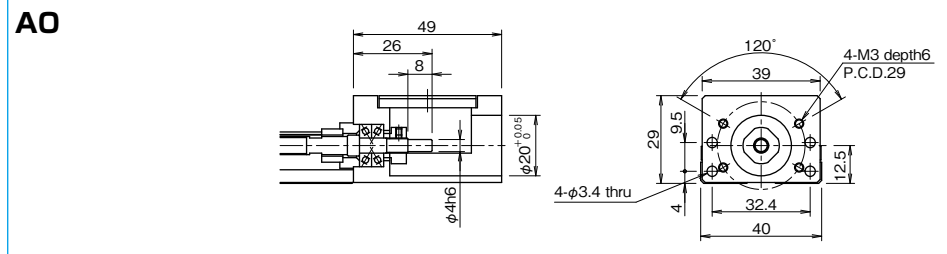

For configurations A5, A6, A9 and AA, attach the motor to the motor mount adapter plate first.

# BG26

Figures inside ( ) indicates mass of the motor mount adapter plate.

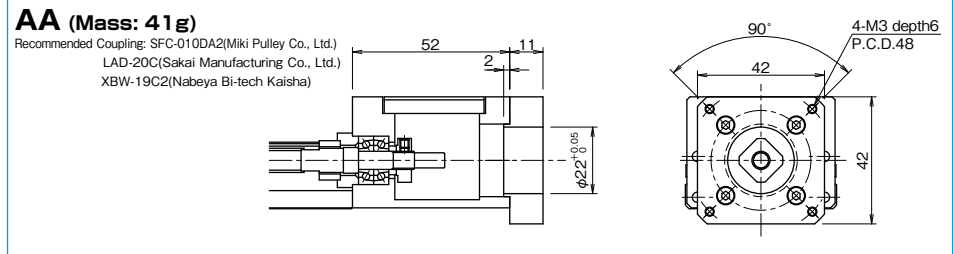
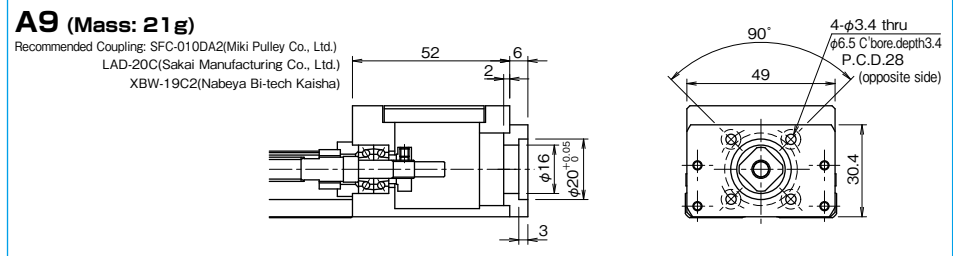
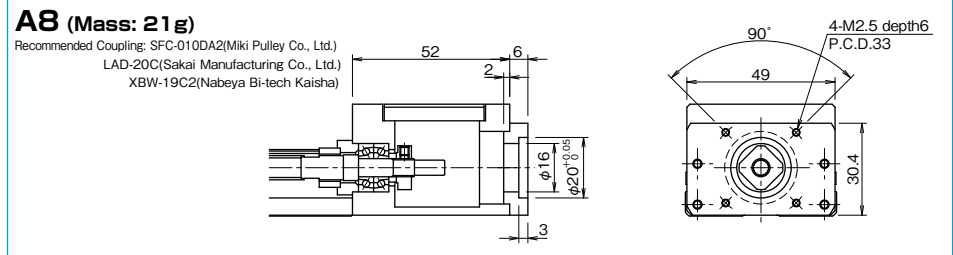
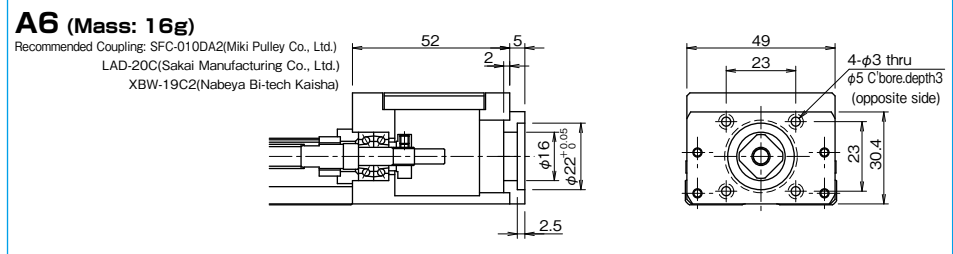
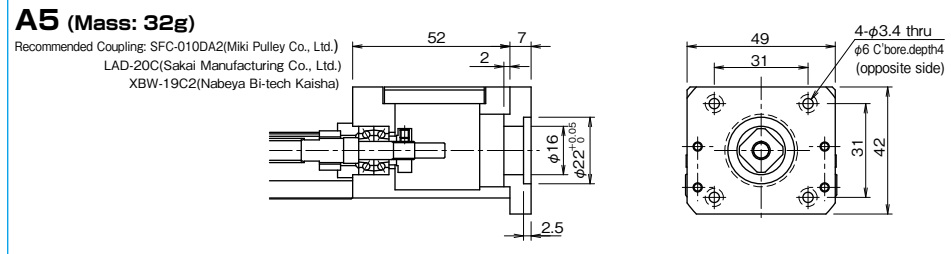
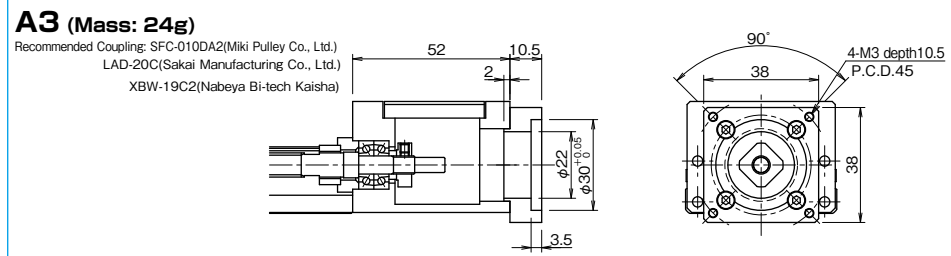
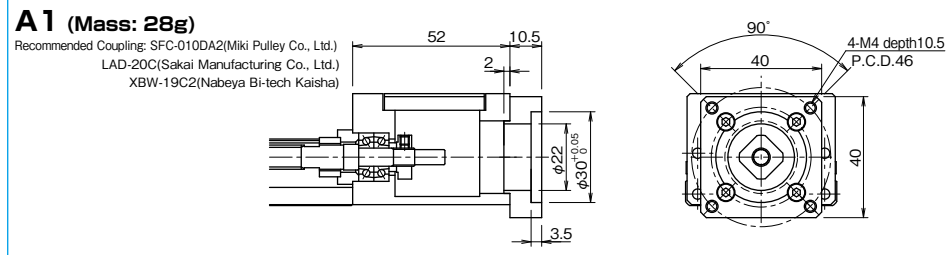
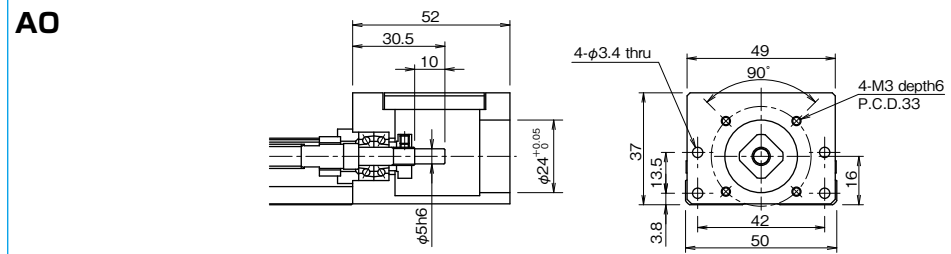

For configurations A5, A6 and A9, attach the motor to the motor mount adapter plate first.

# BG33

Figures inside ( ) indicates mass of the motor mount adapter plate.

## A0

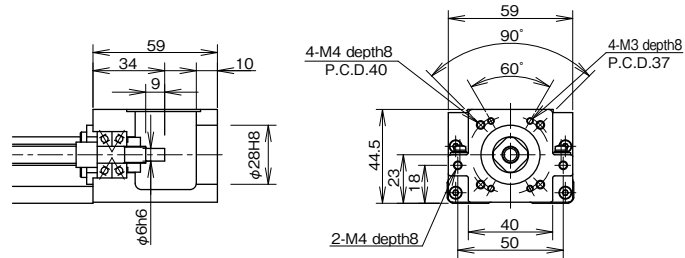

## A1 (Mass: 66g)

Recommended Coupling: SFC-020DA2(Miki Pulley Co., Ltd.)  
LAD-25C(Sakai Manufacturing Co., Ltd.)  
XBW-25C2(Nabeya Bi-tech Kaisha)

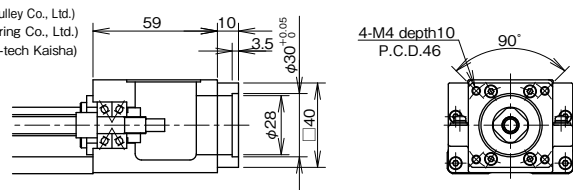

## A2 (Mass: 67g)

Recommended Coupling: SFC-020DA2(Miki Pulley Co., Ltd.)  
LAD-25C(Sakai Manufacturing Co., Ltd.)  
XBW-25C2(Nabeya Bi-tech Kaisha)

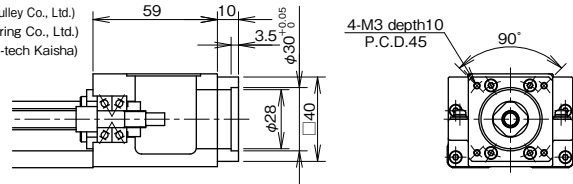

## A3 (Mass: 133g)

Recommended Coupling: SFC-020DA2(Miki Pulley Co., Ltd.)  
LAD-25C(Sakai Manufacturing Co., Ltd.)  
XBW-25C2(Nabeya Bi-tech Kaisha)

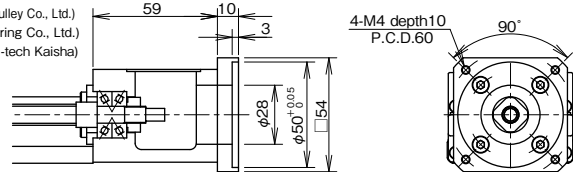

## A5 (Mass: 125g)

Recommended Coupling: SFC-020DA2(Miki Pulley Co., Ltd.)  
LAD-25C(Sakai Manufacturing Co., Ltd.)  
XBW-25C2(Nabeya Bi-tech Kaisha)

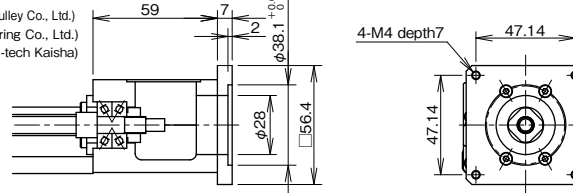

## A6 (Mass: 215g)

Recommended Coupling: XBW-27C2(Nabeya Bi-tech Kaisha)

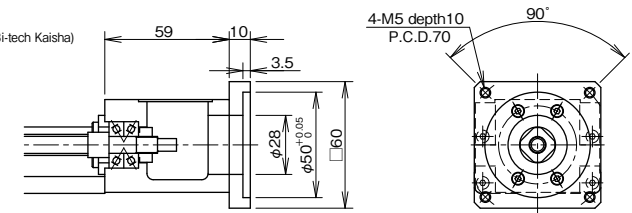

## A7 (Mass: 215g)

Recommended Coupling: XBW-27C2(Nabeya Bi-tech Kaisha)

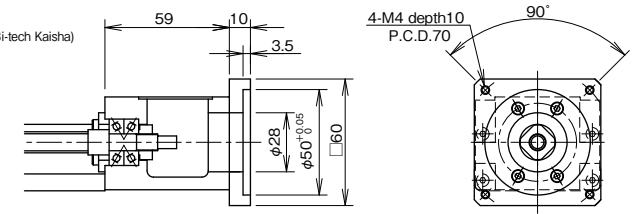

## A8 (Mass: 212g)

Recommended Coupling: SFC-020DA2(Miki Pulley Co., Ltd.)  
LAD-25C(Sakai Manufacturing Co., Ltd.)  
XBW-25C2(Nabeya Bi-tech Kaisha)

\*Please contact NB when you use αSTEP motor (Oriental Motor Co., Ltd.).

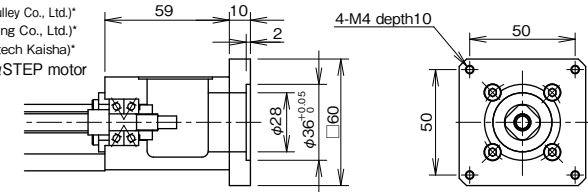

## B1 (Mass: 111g)

Recommended Coupling: SFC-010DA2(Miki Pulley Co., Ltd.)  
LAD-20C(Sakai Manufacturing Co., Ltd.)  
XBW-19C2(Nabeya Bi-tech Kaisha)

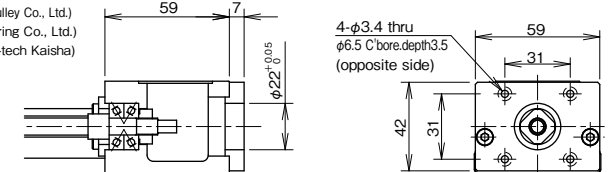

## B2 (Mass: 167g)

Recommended Coupling: LAD-25C(Sakai Manufacturing Co., Ltd.)  
XBW-19C2(Nabeya Bi-tech Kaisha)

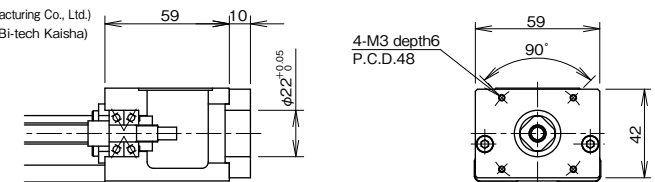

For configurations B1 and B2, attach the motor to the motor mount adapter plate first.

# BG46

Figures inside ( ) indicates mass of the motor mount adapter plate.

**A0**  
 Recommended Coupling: SFC-020DA2(Miki Pulley Co., Ltd.)  
 LAD-25C(Sakai Manufacturing Co., Ltd.)  
 XBW-25C2(Nabeya Bi-tech Kaisha)

**A1 (Mass: 103g)**  
 Recommended Coupling: SFC-030DA2(Miki Pulley Co., Ltd.)  
 LAD-30C(Sakai Manufacturing Co., Ltd.)  
 XBW-34C3(Nabeya Bi-tech Kaisha)

**A2 (Mass: 106g)**  
 Recommended Coupling: SFC-030DA2(Miki Pulley Co., Ltd.)  
 LAD-30C(Sakai Manufacturing Co., Ltd.)  
 XBW-34C3(Nabeya Bi-tech Kaisha)

**A3 (Mass: 448g)**  
 Recommended Coupling (200W-400W): SFC-030DA2(Miki Pulley Co., Ltd.)  
 XBW-34C3(Nabeya Bi-tech Kaisha)  
 (750W): SFC-040DA2(Miki Pulley Co., Ltd.)  
 XBW-39C2(Nabeya Bi-tech Kaisha)

**A4 (Mass: 628g)**  
 Recommended Coupling: SFC-040DA2(Miki Pulley Co., Ltd.)  
 XBW-39C2(Nabeya Bi-tech Kaisha)

**B0**  
 Recommended Coupling: SFC-020DA2(Miki Pulley Co., Ltd.)  
 LAD-25C(Sakai Manufacturing Co., Ltd.)  
 XBW-25C2(Nabeya Bi-tech Kaisha)

**C0**  
 Recommended Coupling: SFC-020DA2(Miki Pulley Co., Ltd.)  
 LAD-25C(Sakai Manufacturing Co., Ltd.)  
 XBW-25C2(Nabeya Bi-tech Kaisha)

**D0**  
 Recommended Coupling: SFC-020DA2(Miki Pulley Co., Ltd.)  
 LAD-25C(Sakai Manufacturing Co., Ltd.)  
 XBW-27C2(Nabeya Bi-tech Kaisha)  
 \*Please contact NB when you use aSTEP motor (Oriental Motor Co., Ltd.).

**D1 (Mass:435g)**  
 Recommended Coupling: LAD-35C(Sakai Manufacturing Co., Ltd.)  
 XBW-34C3(Nabeya Bi-tech Kaisha)  
 \*Please contact NB when you use aSTEP motor (Oriental Motor Co., Ltd.).

# BG55

Figures inside ( ) indicates mass of the motor mount adapter plate.

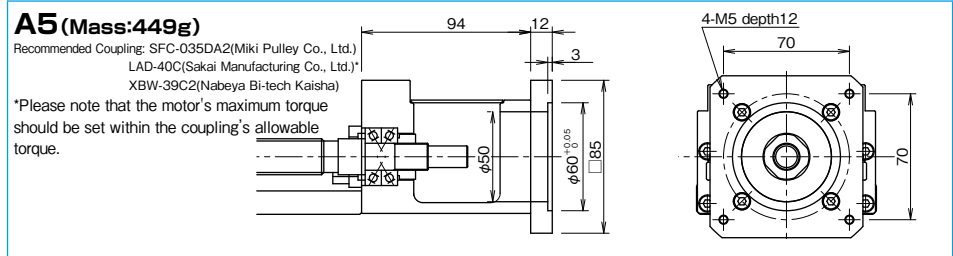
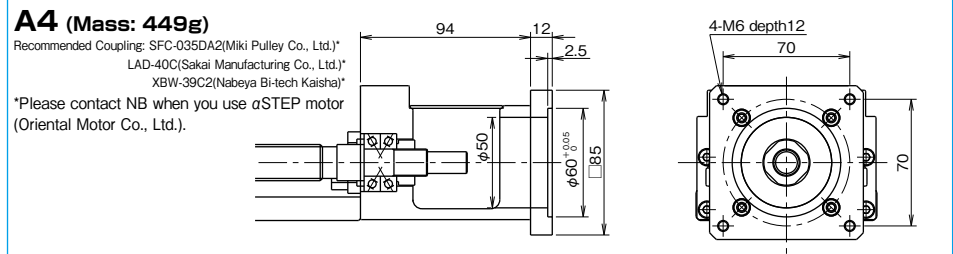
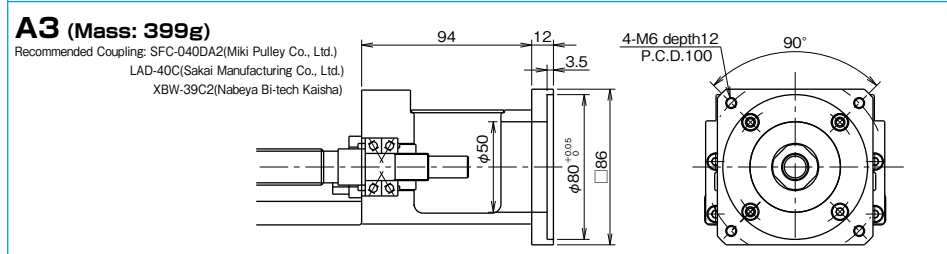
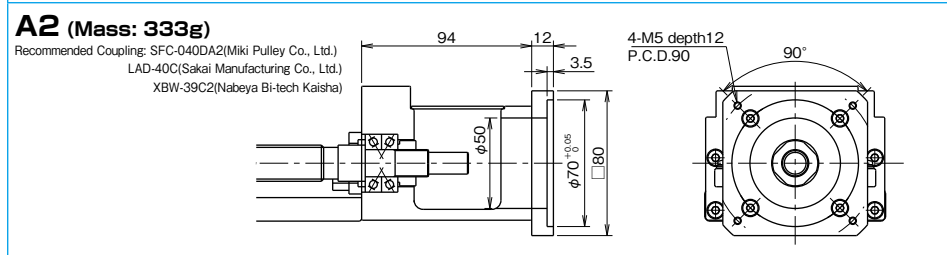
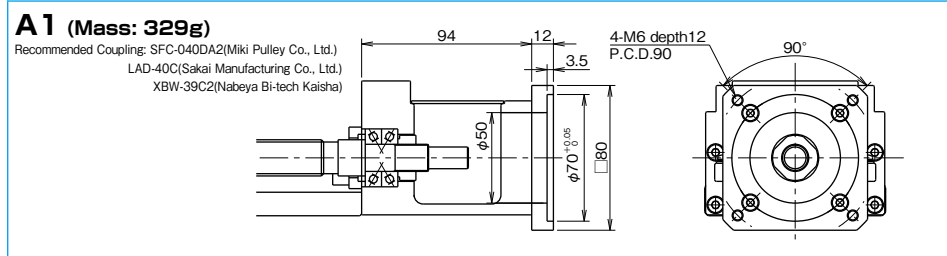
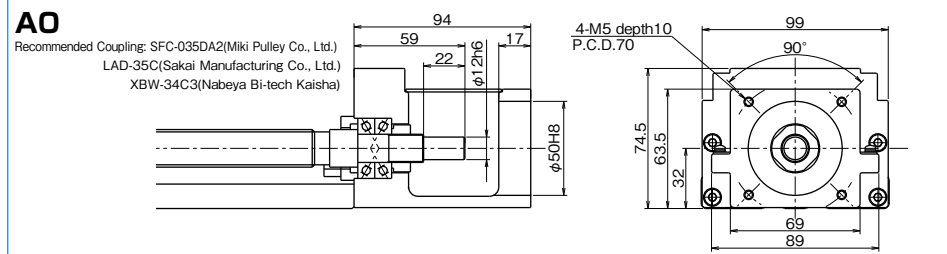

**EXPOSED BRACKET R0**

The ball screw shaft end is exposed with the exposed bracket R0 type.  
Please fabricate an original bracket in case the standard brackets are not applicable.

**BG15**

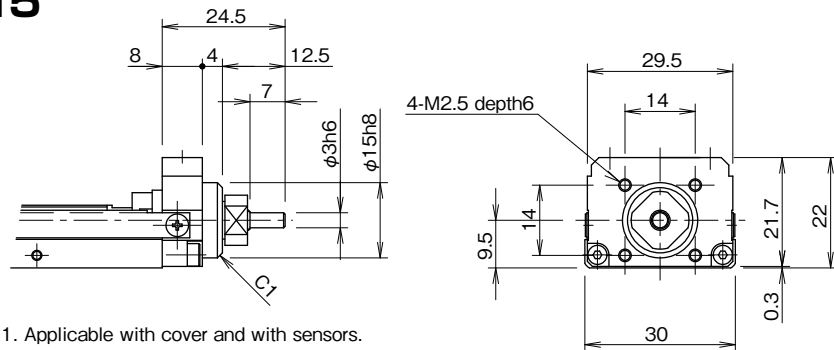

1. Applicable with cover and with sensors.
2. Mass is 0.04kg less than the mass in the table on page H-14.

**BG20**

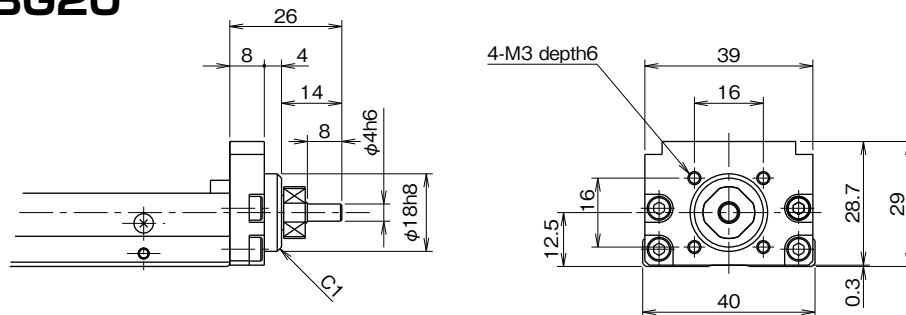

1. Applicable with cover and with sensors.
2. Mass is 0.04kg less than the mass in the table on page H-16.

**BG26**

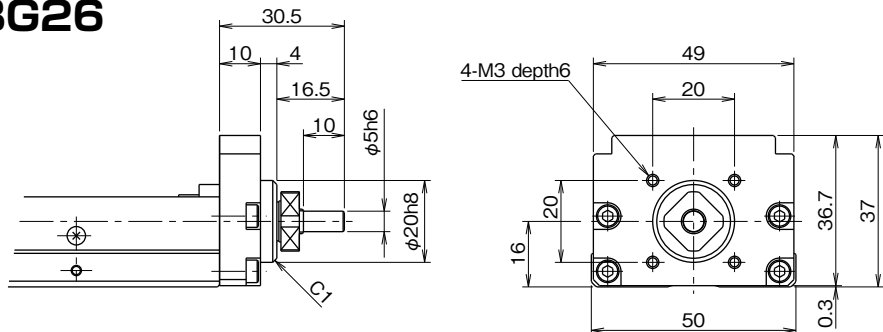

1. Applicable with cover and with sensors.
2. Mass is 0.08kg less than the mass in the table on page H-18.

**BG33**

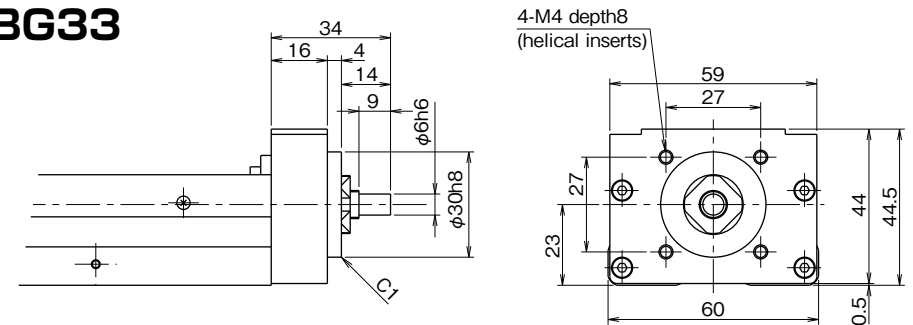

1. Applicable with cover and with sensors.
2. Mass is 0.1kg less than the mass in the table on page H-20,H-22.

**BG46**

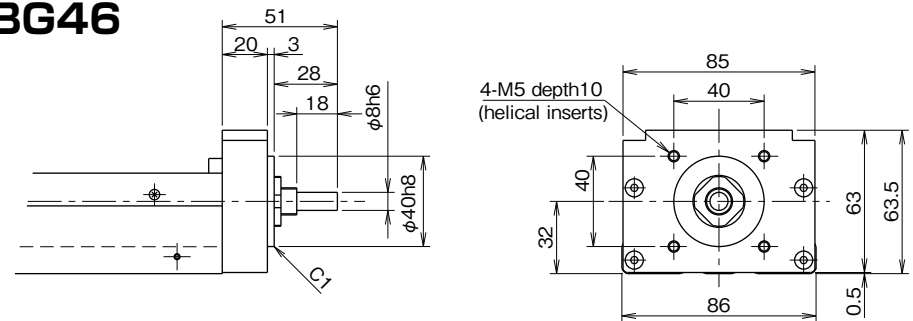

1. Applicable with cover and with sensors.
2. Mass is 0.3kg less than the mass in the table on page H-24,H-26.

**BG55**

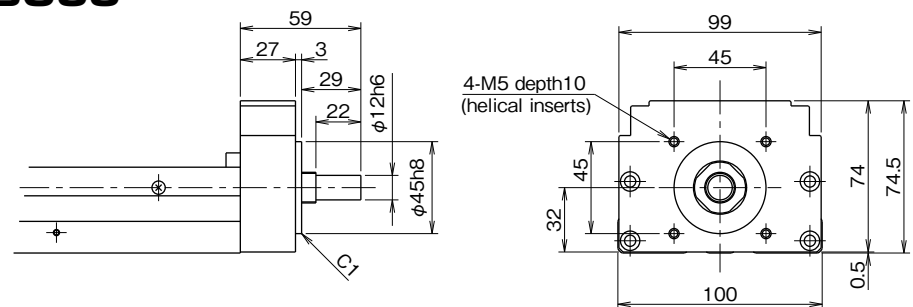

1. Applicable with cover and with sensors.
2. Mass is 0.3kg less than the mass in the table on page H-28.

RETURN PULLEY UNIT

Return pulley units in which a motor is connected with a timing belt are available for BG type. Its return structure allows the reduction of total length (available for BG33 and BG46).

BG33

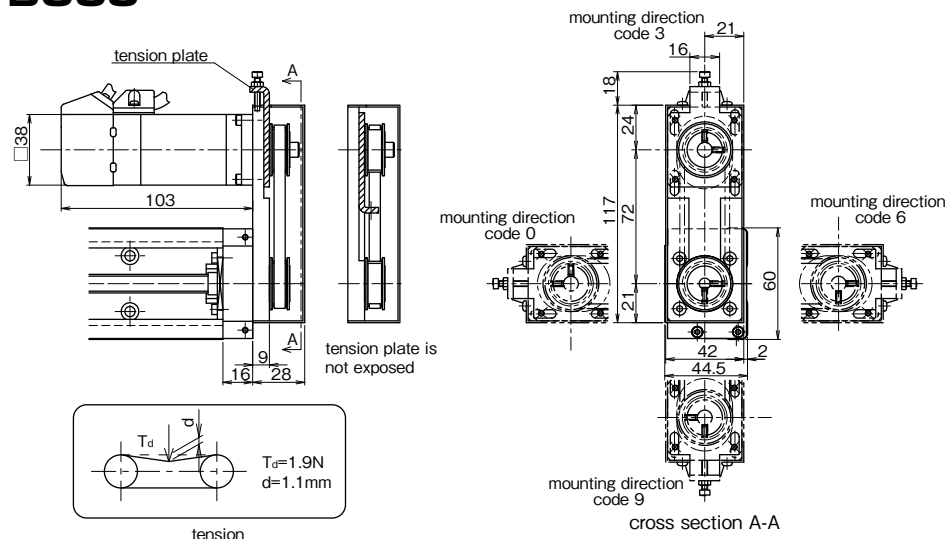

- This drawing shows RA for MSMA01(Panasonic).
- Installation position of Pulley Unit can be selected at 90° intervals (mounting direction code).
- Applicable with cover and with sensors.  
Precaution for applying H type sensors  
When the motor is positioned at direction 3 or 9, H type sensors interfere if mounted on the side of motor. H type sensors must be mounted opposite to the motor.
- Tension plate can be built in and is not exposed. (not applicable to RC)
- Mass is added 0.2kg to the mass on page H-20~23.
- Inertia is added  $2.22 \times 10^{-6} \text{kg} \cdot \text{m}^2$  to the value of Table on page H-20~23. (motor inertia not included)
- Part number structure BG33\*\*\*-\*\*\*\*/☆☆□  
☆☆: Symbol of applicable motor bracket (refer to Table H-10)  
□: Mounting direction code (refer to cross section A-A)

Table H-10 Applicable Motor

motor bracket	applicable motors		output	flange	motor diameter
RA	Panasonic	MINAS SERIES	50~100W	□38	φ8
RB	YASKAWA ELECTRIC	SIGMA SERIES	50~100W	□40	φ8
	MITSUBISHI ELECTRIC	MELSERVO SERIES	50~100W	□40	
	SANYO DENKI	SANMOTIONQ1 SERIES	50~100W	□40	
RC	5 PHASE STEPPING MOTOR		-	□42	φ5

Please contact NB for other stepper motors.

BG46

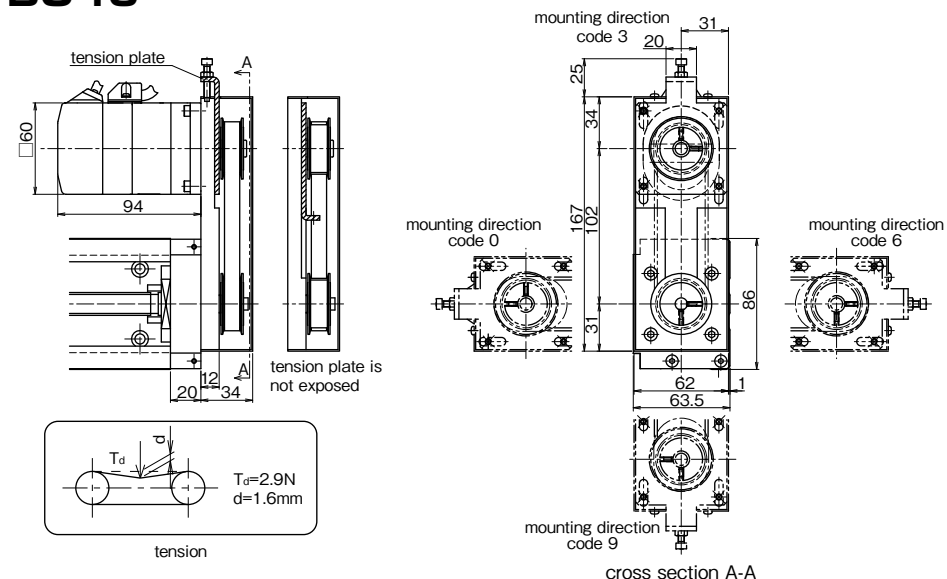

- This drawing shows RA for MSMA01(Panasonic).
- Installation position of Pulley Unit can be selected at 90° intervals (mounting direction code).
- Applicable with cover and with sensors.  
Precaution for applying H type sensors  
When the motor is positioned at direction 3 or 9, H type sensors interfere if mounted on the side of motor. H type sensors must be mounted opposite to the motor.
- Tension plate can be built in and is not exposed.
- Mass is added 0.7kg to the mass on page H-24~27.
- Inertia is added  $1.24 \times 10^{-6} \text{kg} \cdot \text{m}^2$  to the value of Table on page H-24~27. (motor inertia not included)
- Part number structure BG46\*\*\*-\*\*\*\*/☆☆□  
☆☆: Symbol of applicable motor bracket (refer to Table H-11)  
□: Mounting direction code (refer to cross section A-A)

Table H-11 Applicable Motor

motor bracket	applicable motors		output	flange	motor diameter
RA	Panasonic	MINAS SERIES	200W	□60	φ11
RB	YASKAWA ELECTRIC	SIGMA SERIES	200W	□60	φ14
	MITSUBISHI ELECTRIC	MELSERVO SERIES	200W	□60	
	SANYO DENKI	SANMOTIONQ1 SERIES	200W	□60	
RC	5 PHASE STEPPING MOTOR		-	□60	φ8

Please contact NB for other stepper motors.

Return pulley units is available for sizes other than BG33 and BG46. Please contact NB.



**LOW HOUSING**

NB provides low housing with actuators. The height of housing is lower than the block. When the length of work is longer than the block, mounted with standatad housing, the housing contact works. It is recommended to take low housing when long work is mounted. Please note that the height of motor bracket cannot be lower any more.

**BG15**

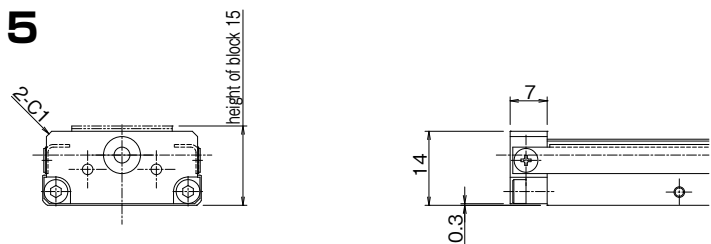

·Mass is 0.005Kg less than the mass on page H-14.

**BG20**

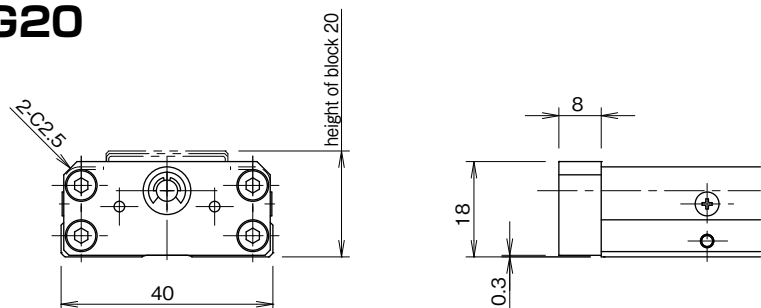

·Mass is 0.01Kg less than the mass on page H-16.

**BG26**

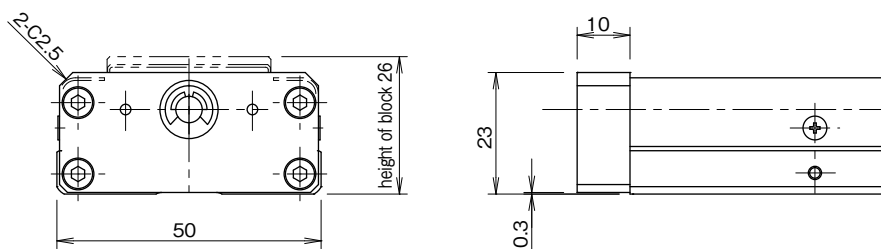

·Mass is 0.02Kg less than the mass on page H-18.

**BG33**

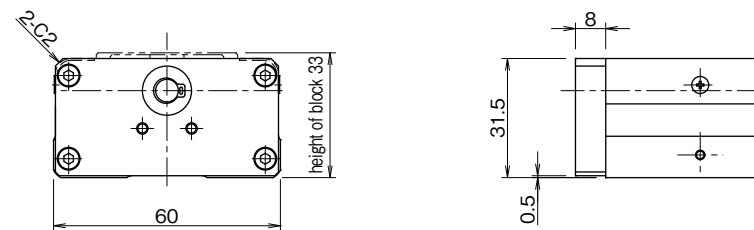

·Mass is 0.02Kg less than the mass on page P.H-20,22.

**BG46**

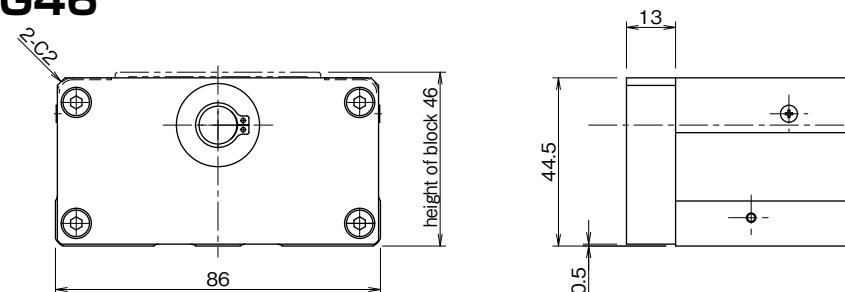

·Mass is 0.05Kg less than the mass on page P.H-24,26.

**BG55**

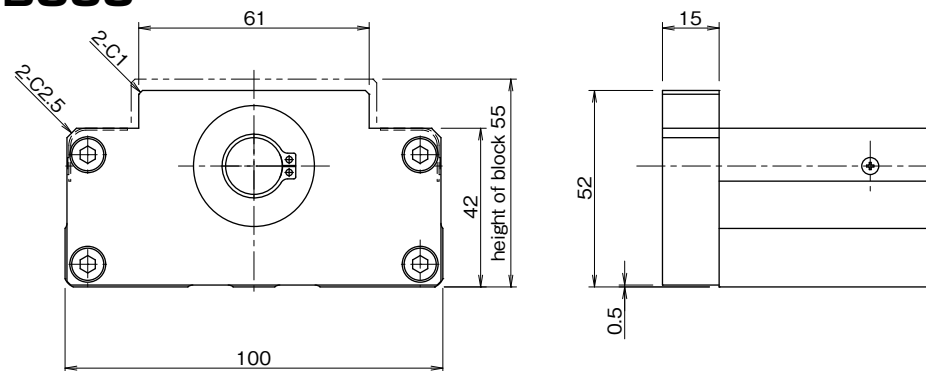

·Mass is 0.1Kg less than the mass on page P.H-28.

**BELLOWS**

BG type can be specified with a cover or bellows for dust prevention. Bellows are securely fixed for various installation methods in positioning and directions. Sensor for bellows is limited to K (proximity sensor) type only, which is pre-installed at proper positions. Please pay attention to the stroke limit of BG with bellows that is shorter than the standard stroke limit.

— Position of Sensor Cable Outlet —

The positions of the outlet for sensor cables can be selected as Figure H-15 shows.

Figure H-15 Position of Sensor Cable Outlet

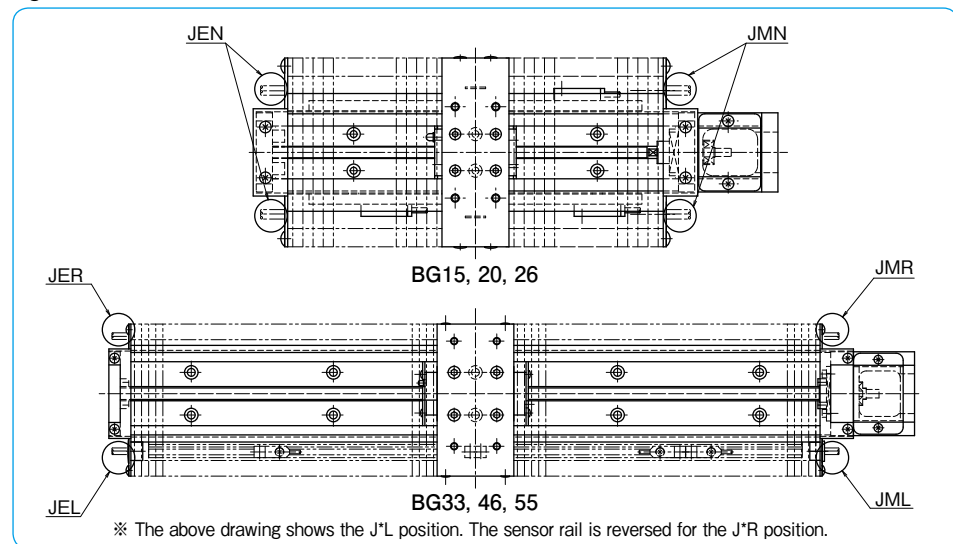

part number structure for bellows

1. J (for the first symbol)
2. Specification of the position of the sensor cable outlet  
Please select the motor side or the housing side.  
M: motor side E: housing side (end plate side)
3. Specification of the position of the sensor rail  
Please select the right hand or the left hand.  
R: on the right from the motor side  
L: on the left from the motor side  
※N for BG15, 20, and 26 since the sensors are mounted on both the right and left hand.
4. JNN for without sensors
5. Sensor type is K (proximity sensor) type only (APM-D3 series: YAMATAKE CORPORATION).

— Sensor Timing Chart —

The following chart shows the standard sensor arrangement.

Figure H-16 Sensor Timing Chart

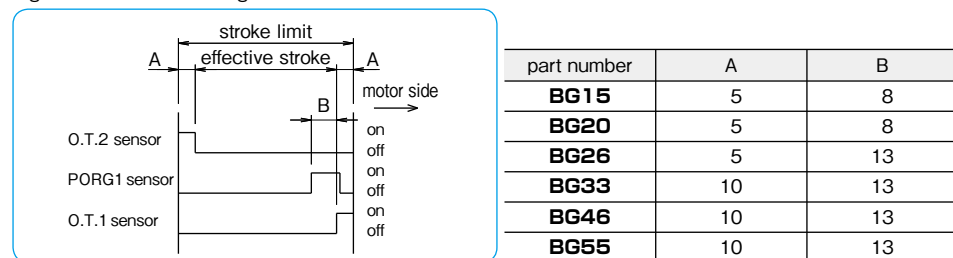

**BG15**  
A(1 long block)

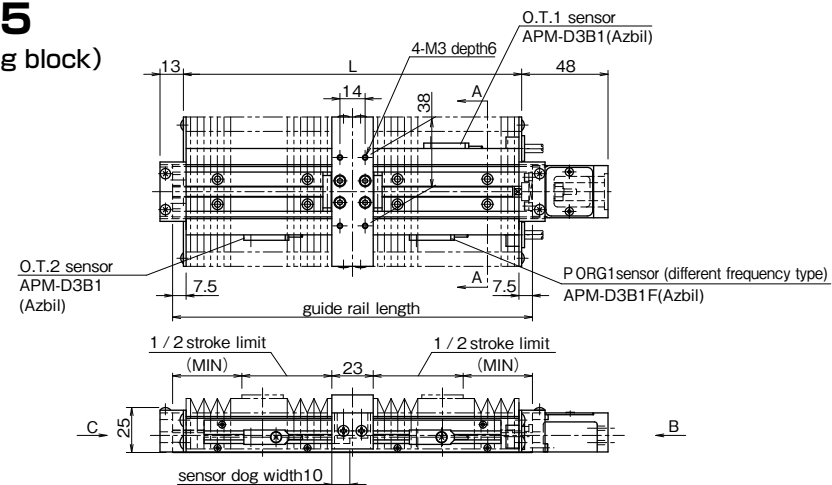

**B(2 long blocks in close contact)**

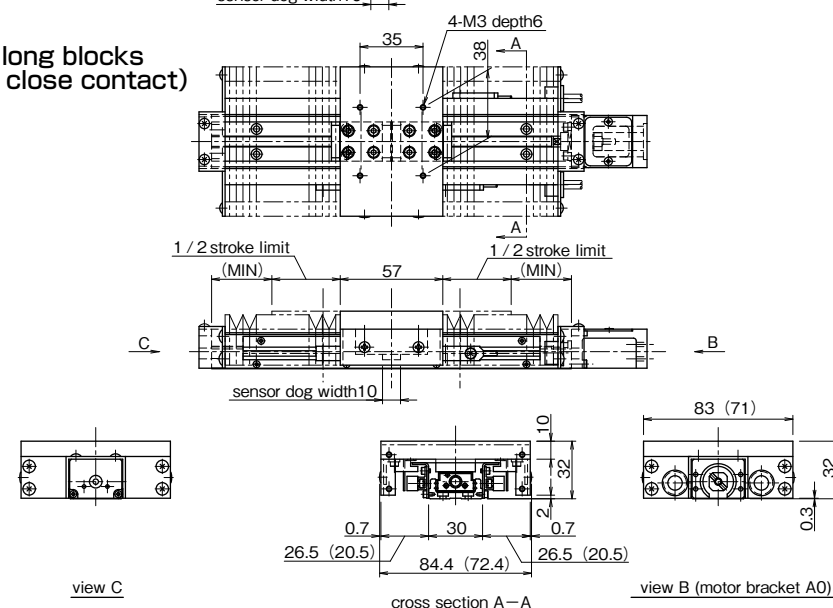

1. The drawings show the "JMN" configuration.
2. The numbers in the parentheses are the dimensions when sensors are not selected.
3. Please refer to page H-14 for dimensions that are not shown on the drawings.
4. material of bellows: composite resin sheet (shining black)

rail length	L	1 long block		2 long blocks			
		stroke limit	effective stroke	MIN	stroke limit	effective stroke	MIN
75	—	—	—	—	—	—	—
100	—	—	—	—	—	—	—
125	113	43	33	29.5	—	—	—
150*	138	60	50	33.5	40	30	26.5
175	163	85	75	33.5	59	49	29.5
200	188	100	90	38.5	76	60	33.5

※ The rail mounting holes at the center cannot be used for the rail length 150 with two long blocks.

# BG20

A(1 long block)

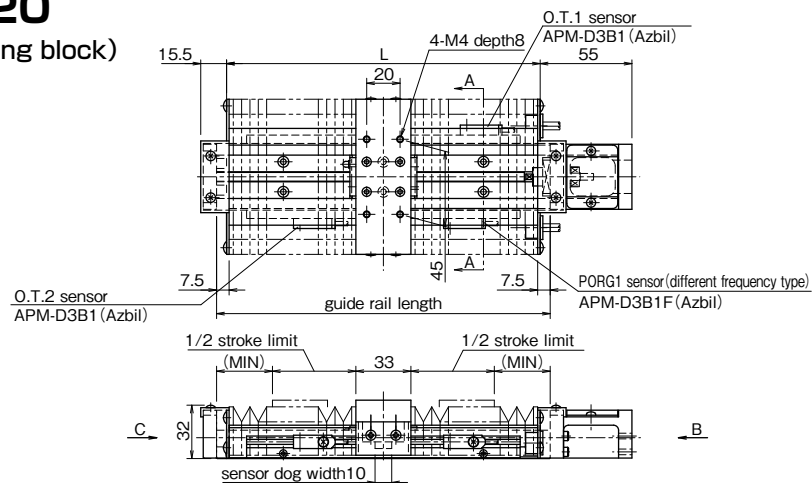

B(2 long blocks in close contact)

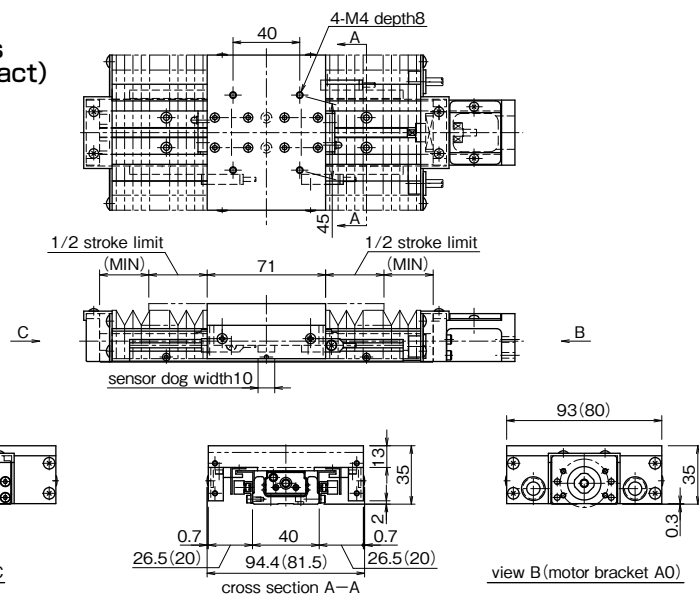

- 1.The drawings show the "JMN" configuration.
- 2.The numbers in the parentheses are the dimensions when sensors are not selected.
- 3.Please refer to page H-16 for dimensions that are not shown on the drawings.
- 4.material of bellows: composite resin sheet (shining black)

rail length	L	1 long block			2 long blocks		
		stroke limit	effective stroke	MIN	stroke limit	effective stroke	MIN
100	—	—	—	—	—	—	—
150*	138	58	48	29.5	32	22	23.5
200	188	100	90	33.5	70	60	29.5

\*The rail mounting holes at the center cannot be used for the rail length 150 with two long blocks.

# BG26

A(1 long block)

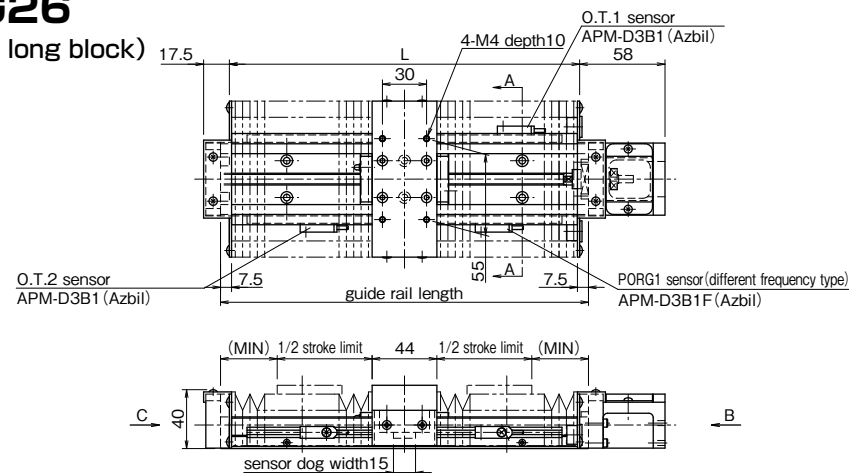

B(2 long blocks in close contact)

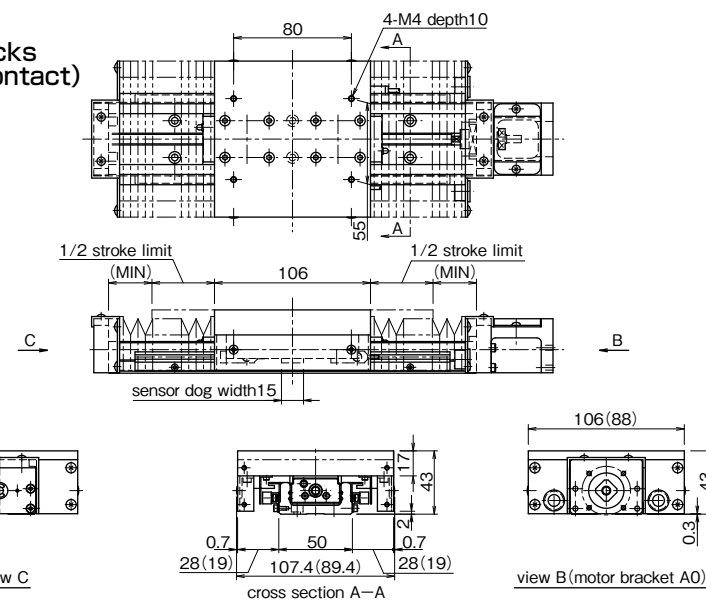

- 1.The drawings show the "JMN" configuration.
- 2.The numbers in the parentheses are the dimensions when sensors are not selected.
- 3.Please refer to page H-18 for dimensions that are not shown on the drawings.
- 4.material of bellows: composite resin sheet (shining black)

rail length	L	1 long block			2 long blocks		
		stroke limit	effective stroke	MIN	stroke limit	effective stroke	MIN
150	138	53	43	26.5	—	—	—
200*	188	97	87	29.5	41	31	26.5
250	238	129	119	38.5	85	75	29.5
300	288	169	159	43.5	127	117	33.5

\*The rail mounting holes at the center cannot be used for the rail length 200 with two long blocks.

# BG33

## A(1 long block)

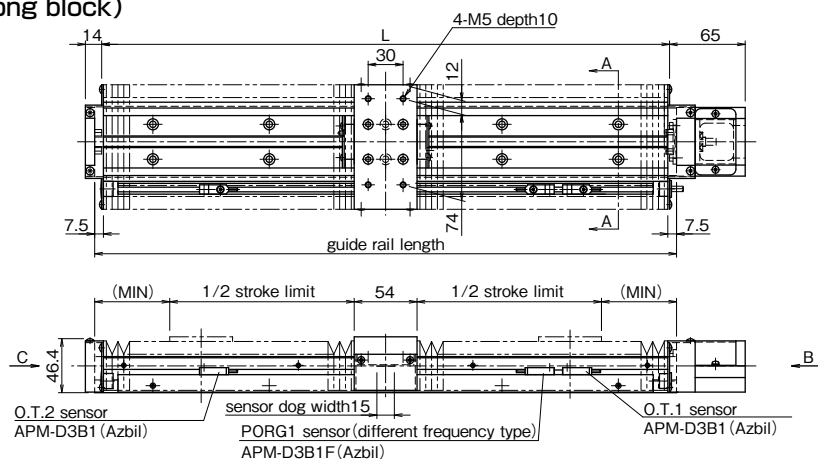

## B(2 long blocks in close contact)

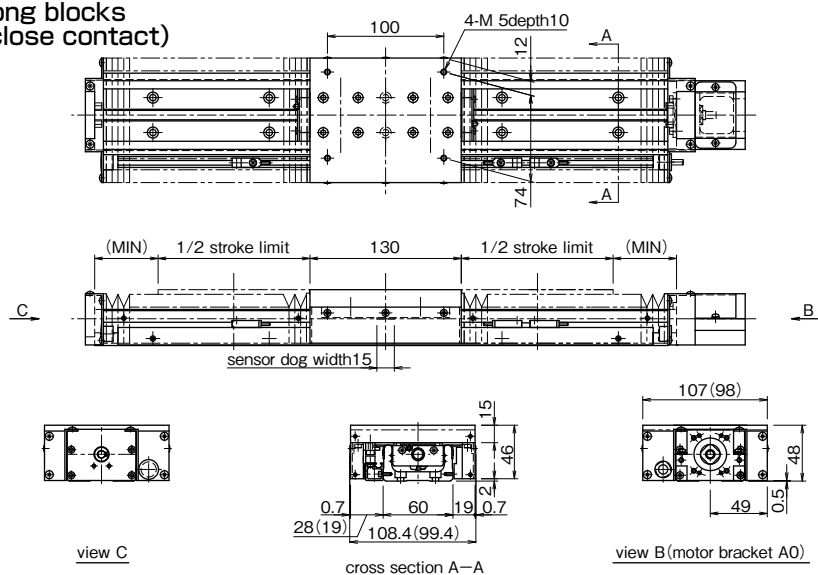

- The drawings show the "JML" configuration. The cross sections become reversed when "J\*R" is selected.
- The numbers in the parentheses are the dimensions when sensors are not selected.
- Please refer to page H-20 for dimensions that are not shown on the drawings.
- material of bellows: composite resin sheet (shining black)

rail length	L	1 long block			2 long blocks		
		stroke limit	effective stroke	MIN	stroke limit	effective stroke	MIN
150	-	-	-	-	-	-	-
200	188	79	59	33.5	-	-	-
300*	288	159	139	43.5	103	83	33.5
400	388	237	217	54.5	183	163	43.5
500	488	317	297	64.5	261	241	54.5
600	588	395	375	75.5	341	321	64.5

\*The rail mounting holes at the center cannot be used for the rail length 300 with two long blocks.

# BG33

## C(1 short block)

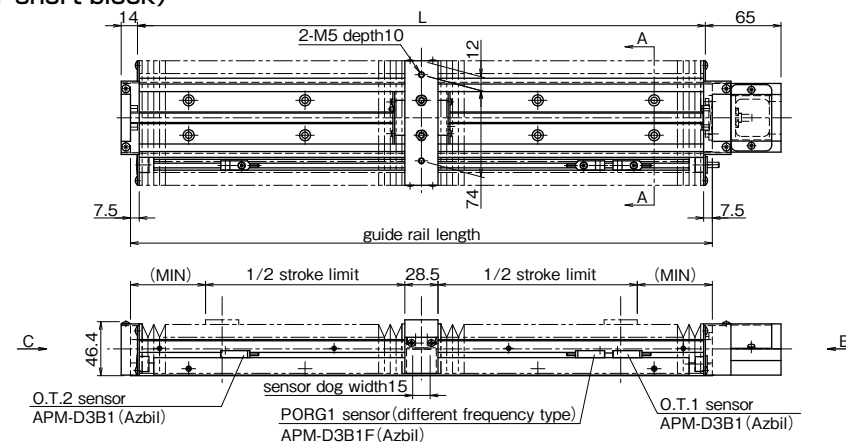

## D(2 short blocks in close contact)

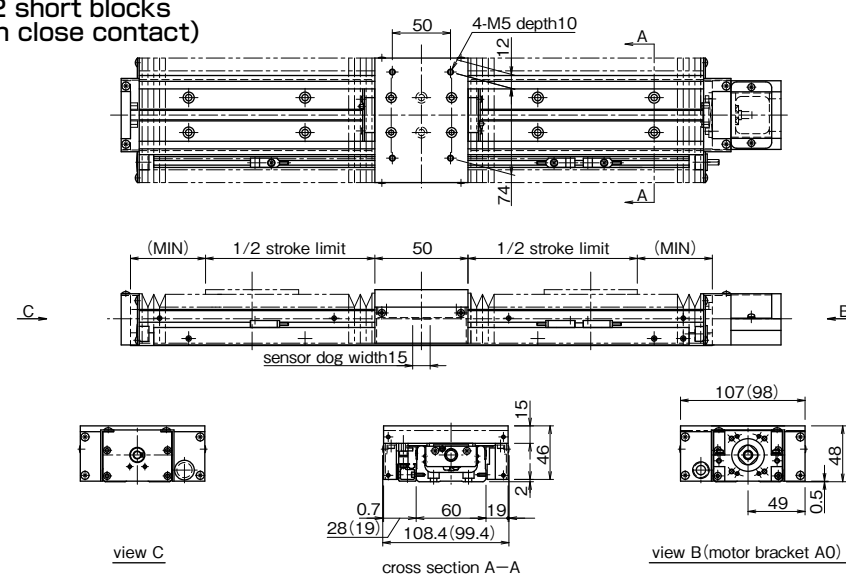

- The drawings show the "JML" configuration. The cross sections become reversed when "J\*R" is selected.
- The numbers in the parentheses are the dimensions when sensors are not selected.
- Please refer to page H-22 for dimensions that are not shown on the drawings.
- material of bellows: composite resin sheet (shining black)

rail length	L	1 short block			2 short blocks		
		stroke limit	effective stroke	MIN	stroke limit	effective stroke	MIN
150	138	68.5	48.5	26.5	-	-	-
200	188	104.5	84.5	33.5	67	47	26.5
300	288	184.5	164.5	43.5	143	123	38.5
400	388	262.5	242.5	54.5	211	191	54.5
500	488	342.5	322.5	64.5	291	271	64.5
600	588	404.5	384.5	83.5	369	349	75.5

# BG46

A(1 long block)

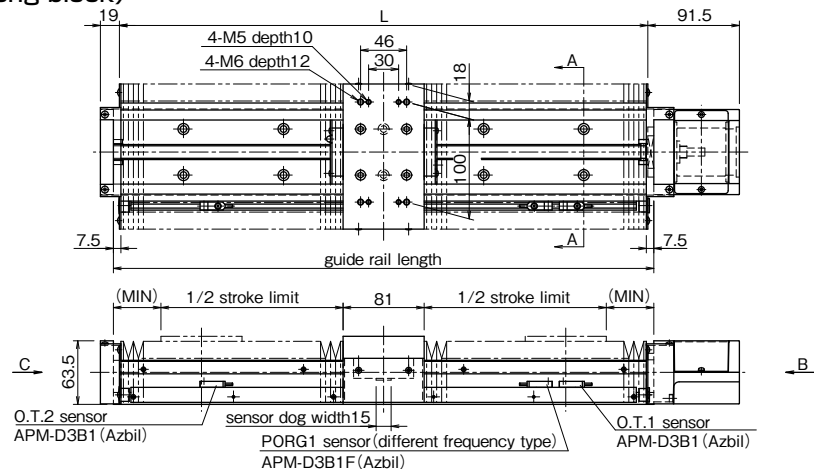

B(2 long blocks in close contact)

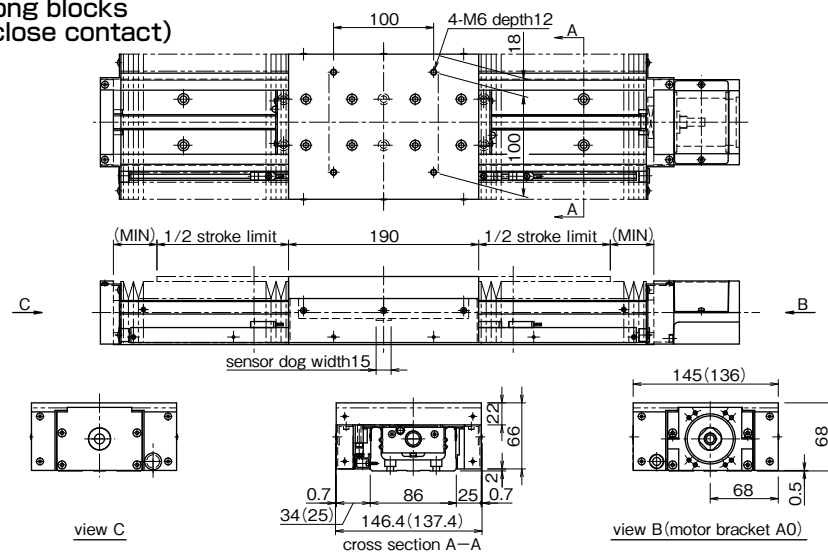

- The drawings show the "JML" configuration. The cross sections become reversed when "J\*R" is selected.
- The numbers in the parentheses are the dimensions when sensors are not selected.
- Please refer to page H-24 for dimensions that are not shown on the drawings.
- material of bellows: composite resin sheet (shining black)

rail length	L	1 long block			2 long blocks		
		stroke limit	effective stroke	MIN	stroke limit	effective stroke	MIN
340*	328	192	172	33.5	97	77	26.5
440	428	272	252	43.5	183	163	33.5
540	528	364	344	47.5	263	243	43.5
640	628	450	430	54.5	355	335	47.5
740	728	530	510	64.5	441	421	54.5
840	828	608	588	75.5	521	501	64.5
940	928	686	666	86.5	599	579	75.5
1,040	1,028	774	754	92.5	677	657	86.5
1,140	1,128	866	846	96.5	765	745	92.5
1,240	1,228	944	924	107.5	857	837	96.5

\*The rail mounting holes at the center cannot be used for the rail length 340 with two short or long blocks.

# BG46

C(1 short block)

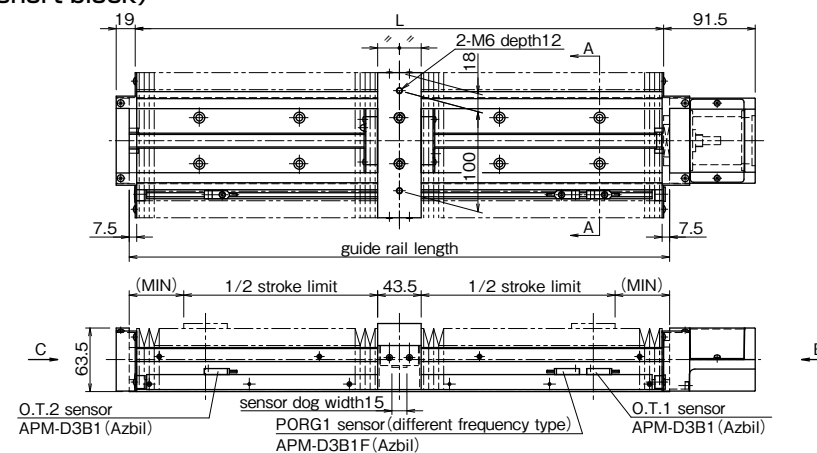

D(2 short blocks in close contact)

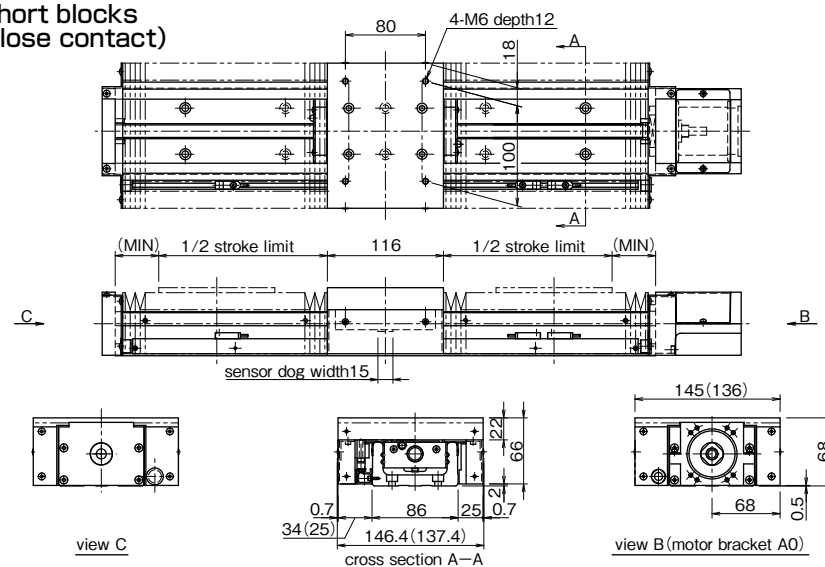

- The drawings show the "JML" configuration. The cross sections become reversed when "J\*R" is selected.
- The numbers in the parentheses are the dimensions when sensors are not selected.
- Please refer to page H-26 for dimensions that are not shown on the drawings.
- material of bellows: composite resin sheet (shining black)

rail length	L	1 short block			2 short blocks		
		stroke limit	effective stroke	MIN	stroke limit	effective stroke	MIN
340*	328	219.5	199.5	38.5	165	145	29.5
440	428	309.5	289.5	43.5	247	227	38.5
540	528	387.5	367.5	54.5	337	317	43.5
640	628	467.5	447.5	64.5	415	395	54.5
740	728	545.5	525.5	75.5	495	475	64.5
840	828	645.5	625.5	75.5	573	553	75.5
940	928	723.5	703.5	86.5	651	631	86.5
1,040	1,028	803.5	783.5	96.5	751	731	86.5
1,140	1,128	881.5	861.5	107.5	831	811	96.5
1,240	1,228	981.5	961.5	107.5	909	889	107.5

\*The rail mounting holes at the center cannot be used for the rail length 340 with two short or long blocks.

# BG55

## A (1 long block)

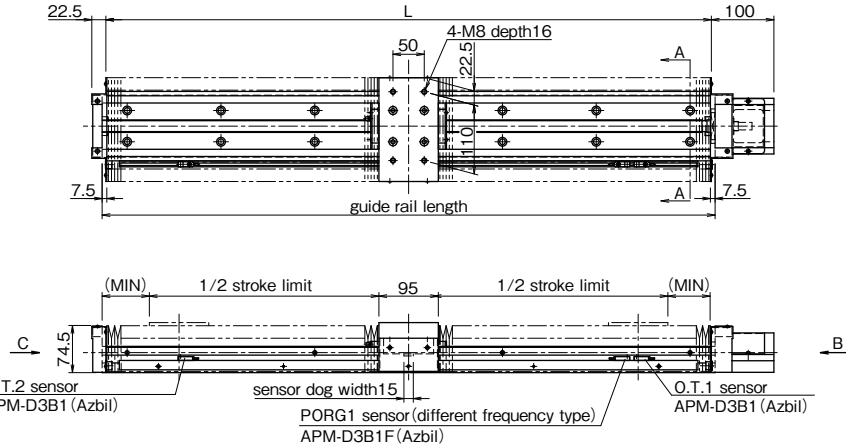

## B (2 long blocks in close contact)

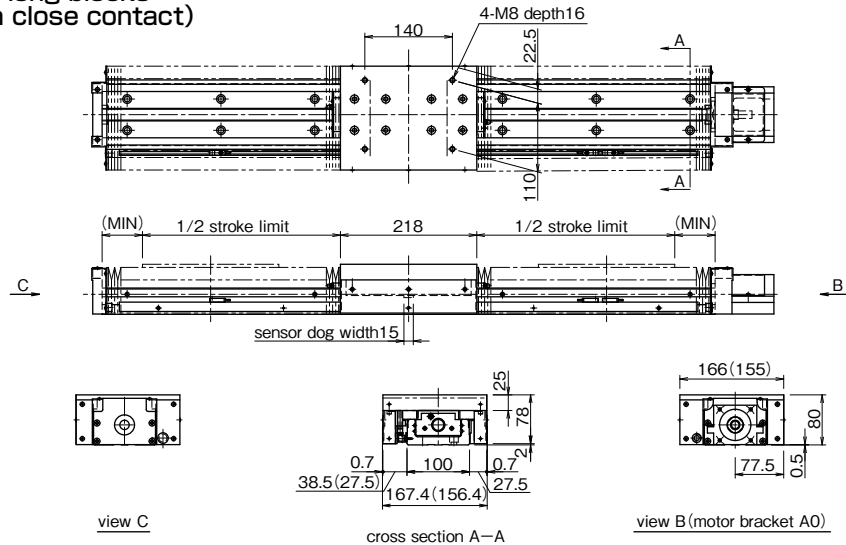

- The drawings show the "JML" configuration. The cross sections become reversed when "J\*R" is selected.
- The numbers in the parentheses are the dimensions when sensors are not selected.
- Please refer to page H-28 for dimensions that are not shown on the drawings.
- material of bellows: composite resin sheet (shining black)

rail length	L	1 long block		2 long blocks			
		stroke limit	effective stroke	MIN	stroke limit	effective stroke	MIN
980	968	734	714	75.5	633	613	64.5
1,080	1,068	812	792	86.5	711	691	75.5
1,180	1,168	912	892	86.5	789	769	86.5
1,280	1,268	992	972	96.5	889	869	86.5
1,380	1,368	1,070	1,050	107.5	969	949	96.5

# SENSOR

Photomicro sensor or proximity sensor can be attached to the BG actuator with our optional sensor-mounting rail (the same length as the guide rail length). Tapped holes are machined on both sides of the guide rail, allowing attachment of sensor to either side. Standard positioning (without special instruction from customer) would be to the left of the motor mount end. Sensor option includes the items that are listed below. Three types of sensor rail are available. (see Figure H-17) For details, please refer to page H-59 ~ H-69. Depending on sizes, some sensor rail are not available.

Table H-12 NPN Sensor

sensor code	sensor type	BG15	BG20	BG26	BG33	BG46	BG55
S	slim/compact type photomicro sensor	—	PM-L24 [3pcs] <sup>※1</sup> (SUNX)				EE-SX674 [3pcs] <sup>※2</sup> (OMRON)
H	close contact capable photomicro sensor						EE-SX671 [3pcs] <sup>※2</sup> (OMRON)
K	proximity sensor (N.C.contact) <sup>※3</sup>					APM-D3B1 [2pcs] <sup>※1</sup> APM-D3B1F [1pcs] <sup>※1※4</sup> (Azbil)	

- ※1 : length of cable: 1m
- ※2 : 3 pcs of sensor connector will be attached
- ※3 : normal close contact
- ※4 : different frequency type

Figure H-17 Sensor rail

sensor rail No. part number	sensor rail1	sensor rail2	sensor rail3
BG15	○	×	×
BG20	○	×	×
BG26	○	×	×
BG33	○	○	○
BG46	○	○	○
BG55	○	○	○

# BG15

## K Specification (Proximity Sensor)

—Without Top Cover—

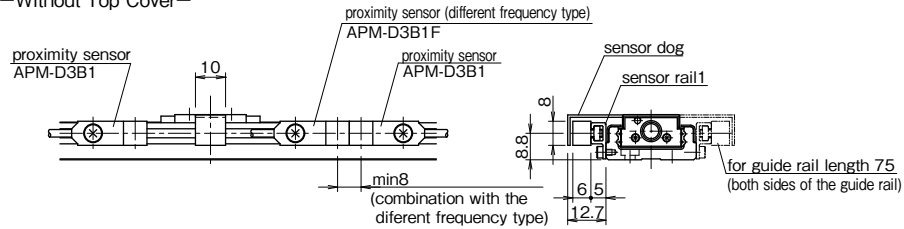

—With Top Cover—

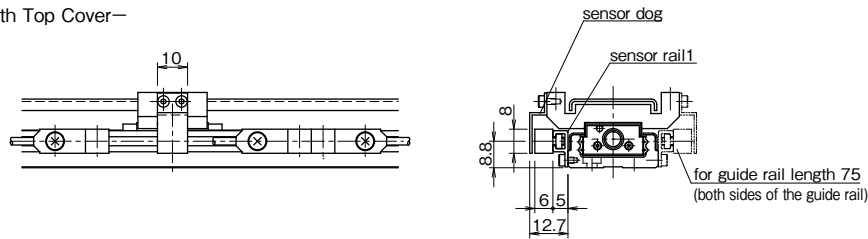

- accessories  
 proximity sensor (APM-D3B1, Azbil) 2 pcs  
 proximity sensor (different frequency type)(APM-D3B1F, Azbil) 1 pc  
 sensor rail 1 pc  
 sensor dog 1 pc  
 \*2 pcs of sensor dogs for BG15A-75  
 (refer to the figure on the right.)

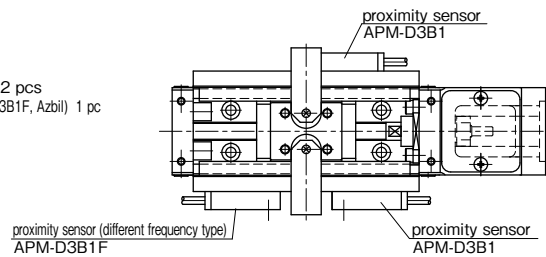

# BG20

## S Specification (Compact Photomicro Sensor)

—Without Top Cover—

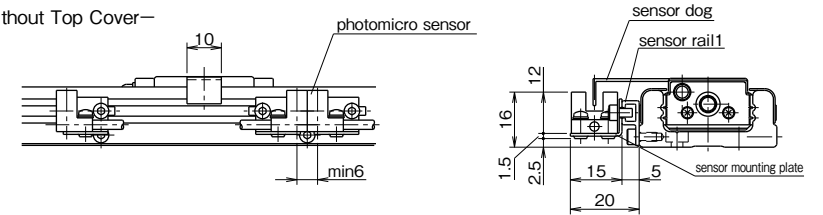

—With Top Cover—

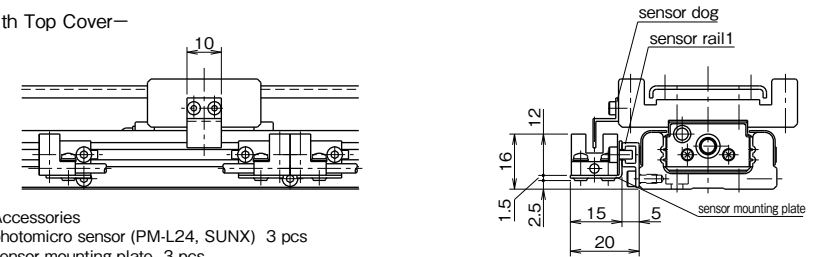

- Accessories  
 photomicro sensor (PM-L24, SUNX) 3 pcs  
 sensor mounting plate 3 pcs  
 sensor rail 1 pc  
 sensor dog 1 pc

## K Specification (Proximity Sensor)

—Without Top Cover—

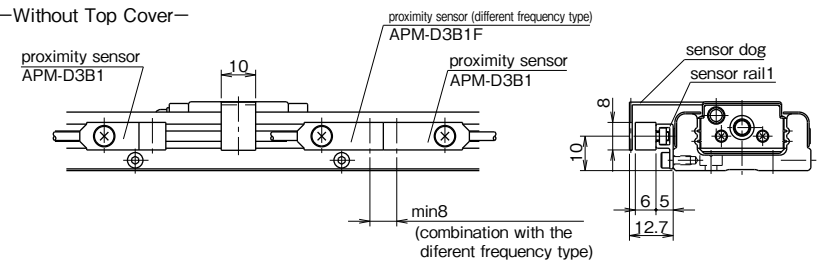

—With Top Cover—

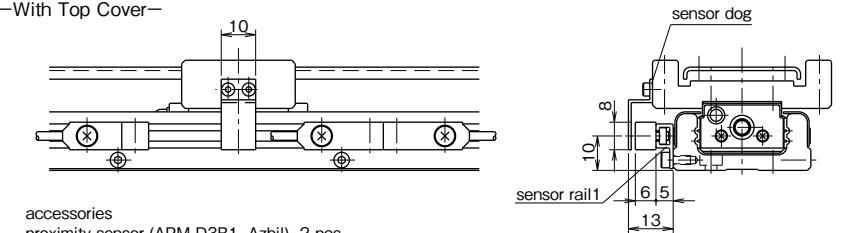

- accessories  
 proximity sensor (APM-D3B1, Azbil) 2 pcs  
 proximity sensor (different frequency type)(APM-D3B1F, Azbil) 1 pc  
 sensor rail 1 pc  
 sensor dog 1 pc

# BG26

## S Specification (Compact Photomicro Sensor)

—Without Top Cover—

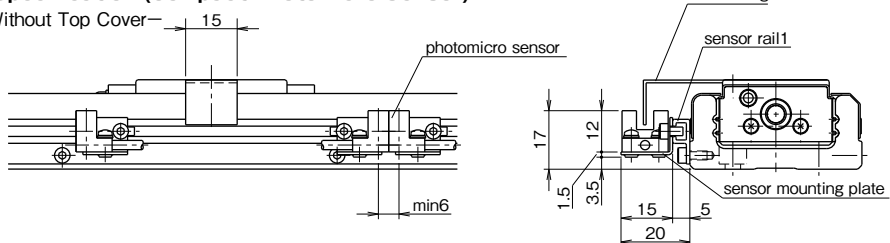

—With Top Cover—

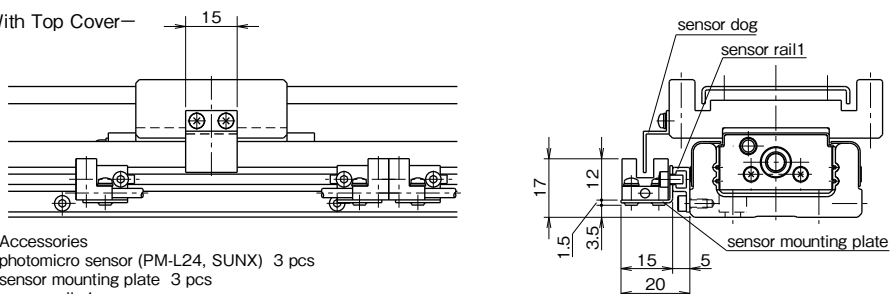

- Accessories  
 photomicro sensor (PM-L24, SUNX) 3 pcs  
 sensor mounting plate 3 pcs  
 sensor rail 1 pc  
 sensor dog 1 pc

## K Specification (Proximity Sensor)

—Without Top Cover—

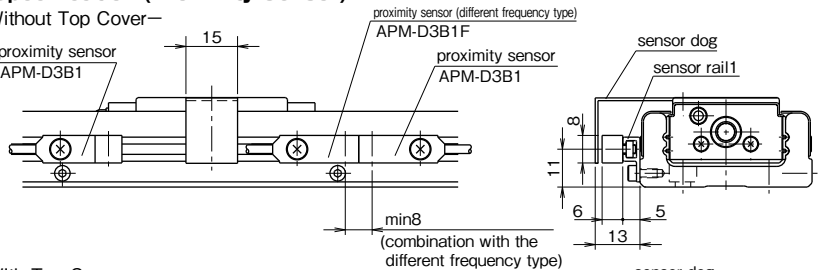

—With Top Cover—

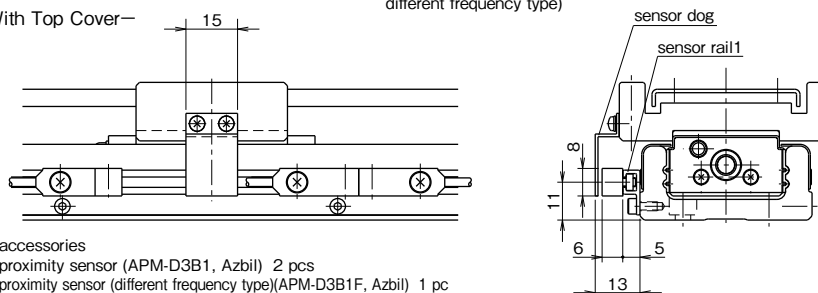

- accessories  
 proximity sensor (APM-D3B1, Azbil) 2 pcs  
 proximity sensor (different frequency type)(APM-D3B1F, Azbil) 1 pc  
 sensor rail 1 pc  
 sensor dog 1 pc

# BG33

## S Specification (Slim-Type Photomicro Sensor)

—Without Top Cover—

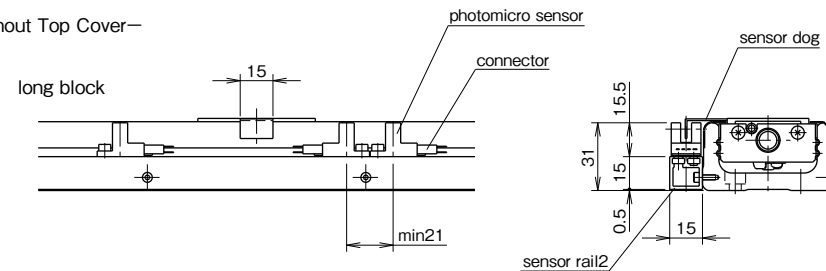

long block

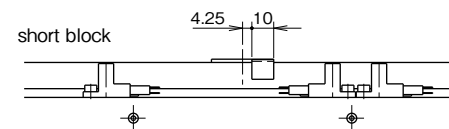

short block

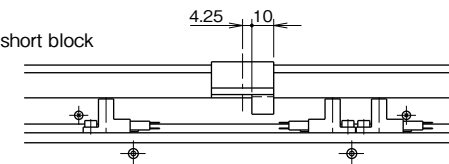

—With Top Cover—

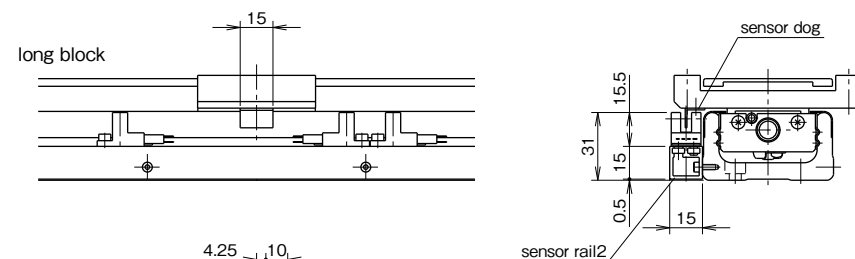

- accessories  
 photomicro sensor (EE-SX674, OMRON) 3 pcs  
 connector (EE-1001, OMRON) 3 pcs  
 sensor rail 1 pc  
 sensor dog \*1 pc  
 \* 2 pcs for BG33D-150.



# BG33

## H Specification (Close Contact Capable Photomicro Sensor)

—Without Top Cover—

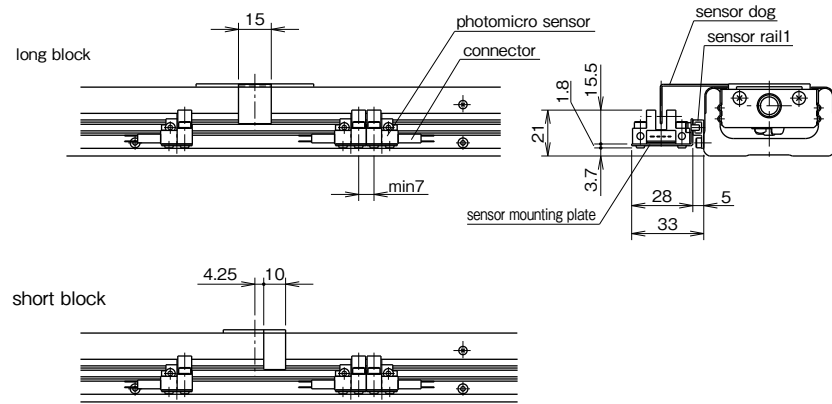

—With Top Cover—

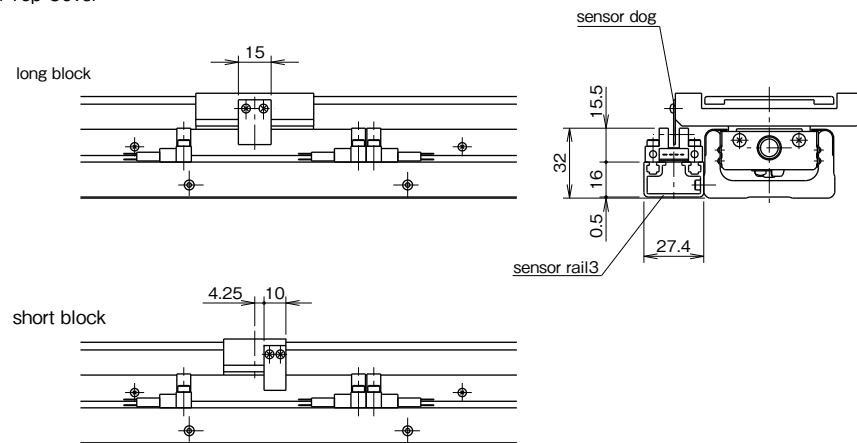

- accessories  
 photomicro sensor (EE-SX671, OMRON) 3 pcs  
 connector (EE-1001, OMRON) 3 pcs  
 sensor mounting plate (only for the without cover type) 3 pcs  
 sensor rail 1 pc  
 sensor dog \*1 pcs  
 \* 2 pcs for BG33D-150.

# BG33

## K Specification (Proximity Sensor)

—Without Top Cover—

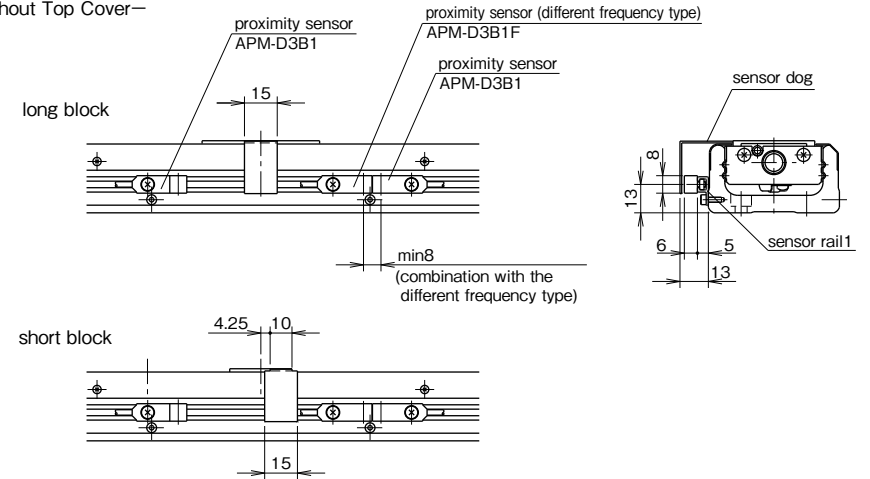

—With Top Cover—

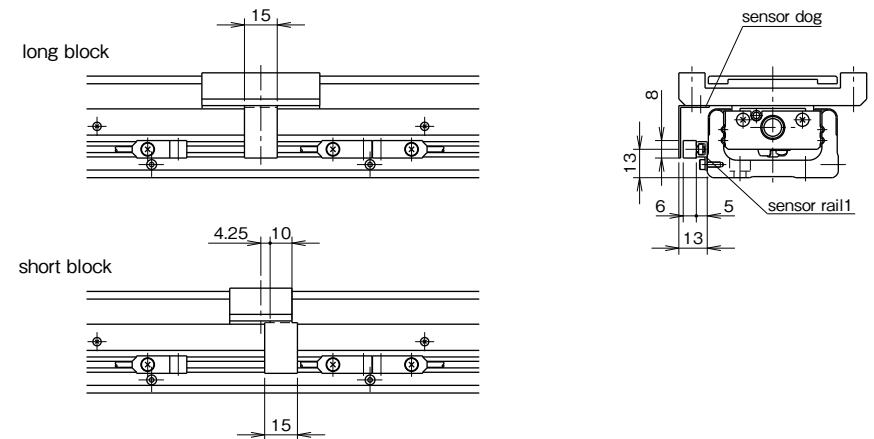

- accessories  
 proximity sensor (APM-D3B1, Azbil) 2 pcs  
 proximity sensor (different frequency type)(APM-D3B1F, Azbil) 1 pc  
 sensor rail 1 pc  
 sensor dog \*1 pc  
 \* 2 pcs for BG33D-150.

# BG46

## S Specification (Slim-Type Photomicro Sensor)

—Without Top Cover—

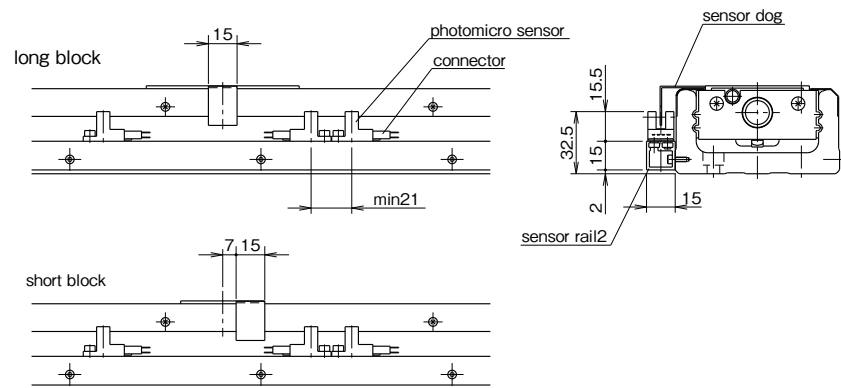

—With Top Cover—

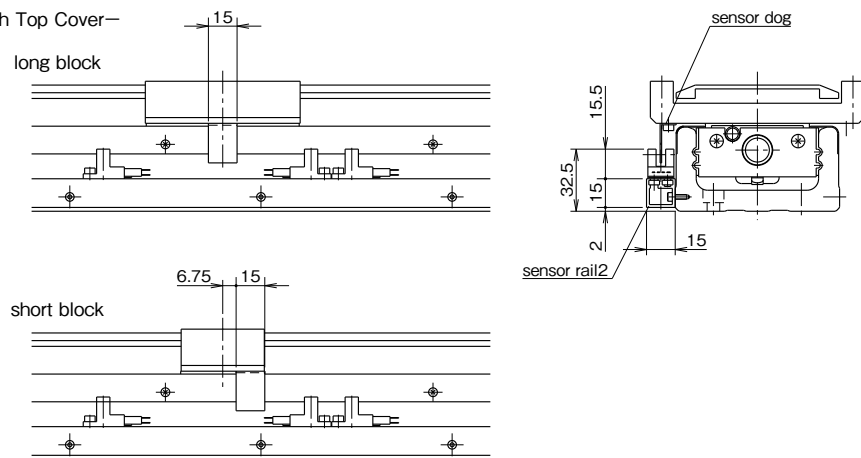

- accessories  
 photomicro sensor (EE-SX674, OMRON) 3 pcs  
 connector (EE-1001, OMRON) 3 pcs  
 sensor rail 1 pc  
 sensor dog 1 pc

# BG46

## H Specification (Close Contact Capable Photomicro Sensor)

—Without Top Cover—

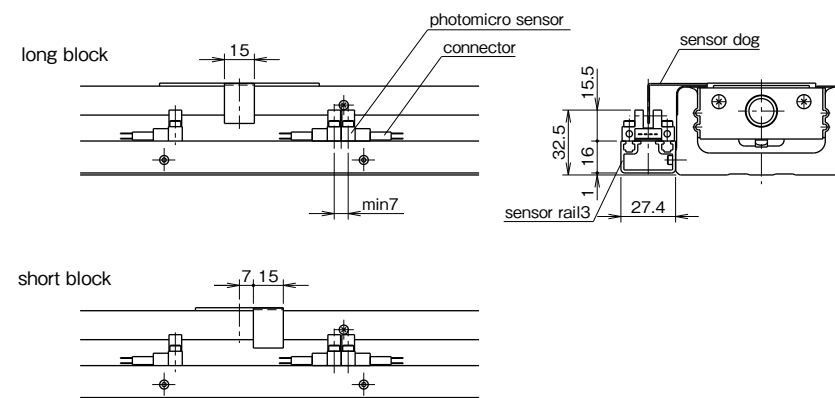

—With Top Cover—

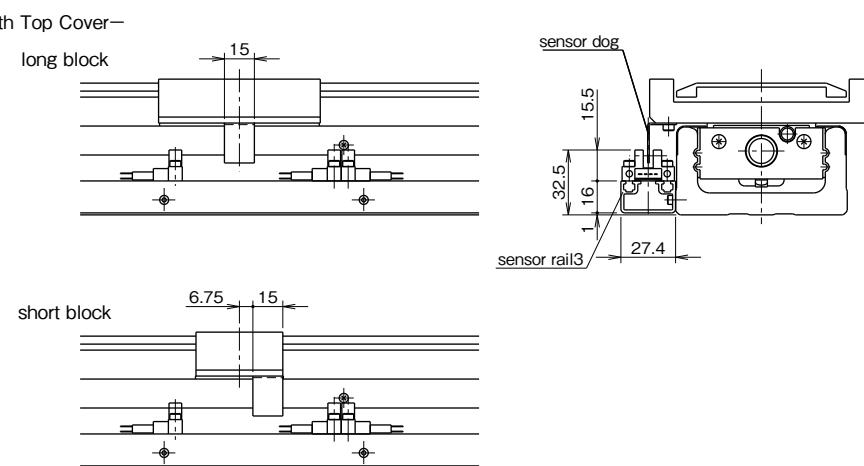

- accessories  
 photomicro sensor (EE-SX671, OMRON) 3 pcs  
 connector (EE-1001, OMRON) 3 pcs  
 sensor rail 1 pc  
 sensor dog 1 pc

# BG46

## K Specification (Proximity Sensor)

—Without Top Cover—

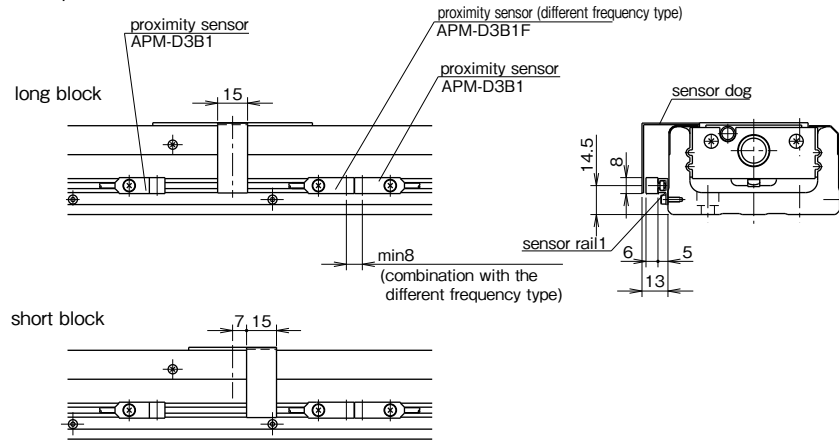

—With Top Cover—

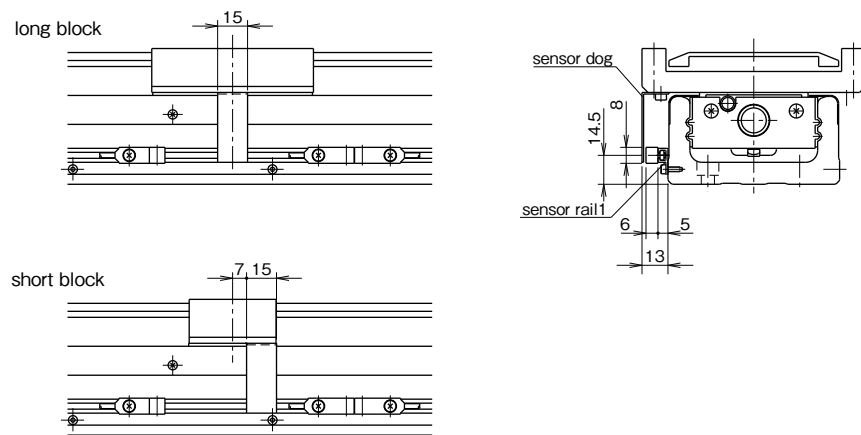

- accessories  
 proximity sensor (APM-D3B1, Azbil) 2 pcs  
 proximity sensor (different frequency type)(APM-D3B1F, Azbil) 1 pc  
 sensor rail 1 pc  
 sensor dog 1 pc

# BG55

## S Specification (Compact Photomicro Sensor)

—Without Top Cover—

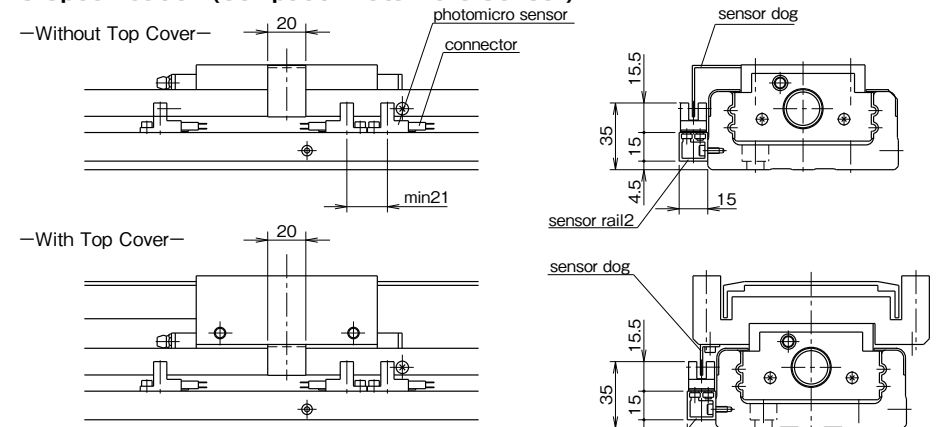

—With Top Cover—

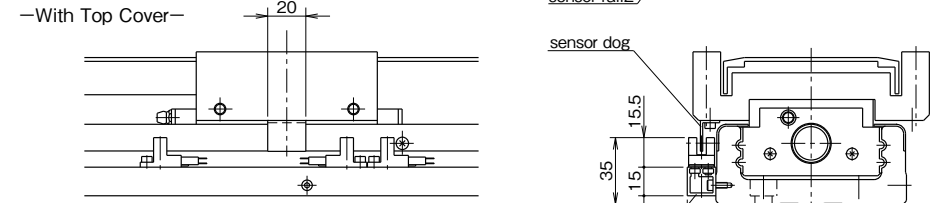

- accessories  
 photomicro sensor (EE-SX674, OMRON) 3 pcs  
 connector (EE-1001, OMRON) 3 pcs  
 sensor rail 1 pc  
 sensor dog 1 pc

## H Specification (Close Contact Capable Photomicro Sensor)

—Without Top Cover—

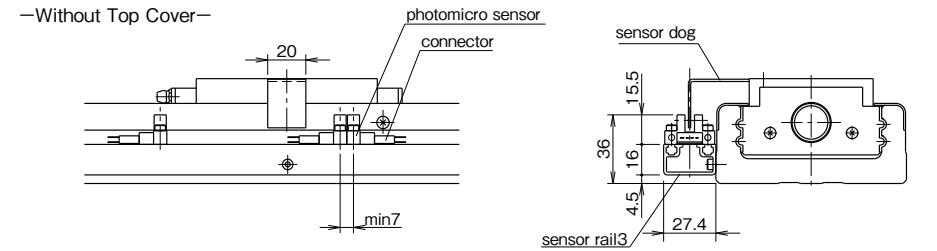

—With Top Cover—

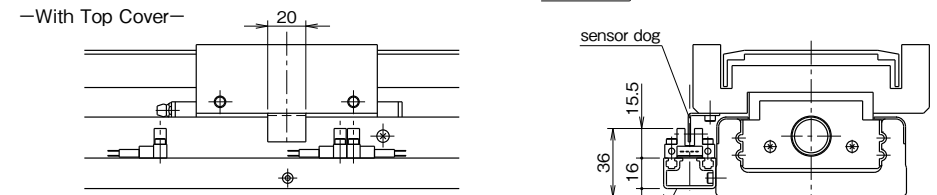

- accessories  
 photomicro sensor (EE-SX671, OMRON) 3 pcs  
 connector (EE-1001, OMRON) 3 pcs  
 sensor rail 1 pc  
 sensor dog 1 pc

# BG55

## K Specification (Proximity Sensor)

—Without Top Cover—

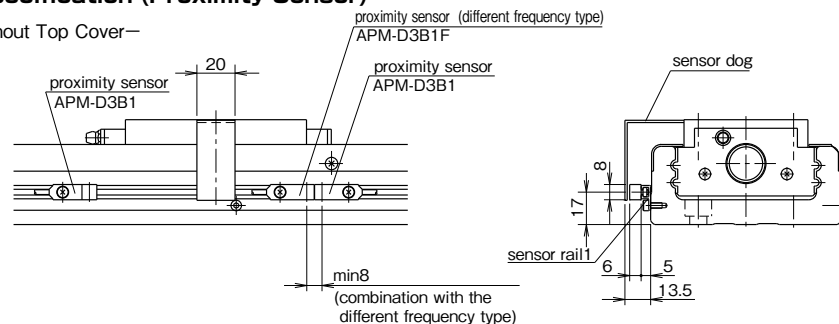

—With Top Cover—

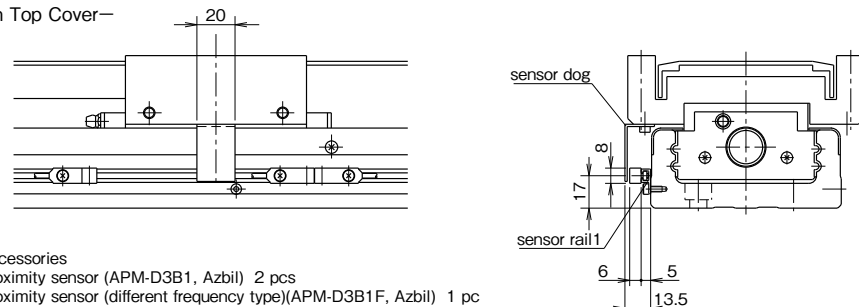

- accessories  
 proximity sensor (APM-D3B1, Azbil) 2 pcs  
 proximity sensor (different frequency type)(APM-D3B1F, Azbil) 1 pc  
 sensor rail 1 pc  
 sensor dog 1 pc

## PNP SENSOR

For the BG type sensors can be changed to the PNP type by adding a sensor option code "PNP" at the end of the part number.

Refer to Table H-12 for the model number of PNP type sensors.

Table H-13 PNP Sensor Type

sensor code	sensor type	BG15	BG20	BG26	BG33	BG46	BG55
S	slim/compact type photomicro sensor	—	PM-L24 P [3pcs] ※1 (SUNX)				EE-SX674P [3pcs] ※2
H	close contact capable photomicro sensor						EE-SX671P [ 3pcs] ※2 (OMRON)
K	proximity sensor (N.C. contact) ※3			APM-D3E1 [2pcs] ※1 APM-D3E1F [1pcs] ※1※4 (Azbil)			

※ 1 : length of cable: 1m  
 ※ 2 : 3 pcs of sensor connector will be attached  
 ※ 3 : normal close contact  
 ※ 4 : different frequency type

## SENSOR SPECIFICATIONS

slim-type, close contact capable photomicro sensor (symbol: S,H)/ OMRON CORPORATION

type	NPN TYPE	EE-SX674	EE-SX671
	PNP TYPE	EE-SX674P	EE-SX671P
sensing distance	5mm (slot width)		
standard sensing object	opaque: 2×0.8mm min.		
differential travel	0.025mm		
power supply voltage	5 to 24 VDC ±10%, ripple(P-P): 10% max.		
current consumption	12mA max. (NPN), 12 mA max.(PNP)		
control output	NPN TYPE	NPN open collector output models: At 5 to 24 VDC: 100-mA load current (Ic) with a residual voltage of 0.8V max.40-mA load current (Ic) with a residual voltage of 0.4V max.	
	PNP TYPE	PNP open collector output models: At 5 to 24 VDC: 50-mA load current (Ic) with a residual voltage of 1.3V max.	
output operation	Dark-On (+, L terminal open-circuit), Light-On (+, L terminal short-circuit)		
response frequency	1kHz max. (3kHz average)		
operation indicator	operation indicator (red) lit with incident		
ambient illumination (on receiver lens)	fluorescent light: 1000 lx max.		
ambient temperature	operating: -25 to 55°C storage: -30 to 80°C		
ambient humidity	operating: 5 to 85%RH storage: 5 to 95%RH		
vibration resistance	destruction: 20 to 2000Hz, (with a peak acceleration of 100m/s <sup>2</sup> ) 1.5mm double amplitude for 2hrs (with 4-minute cycles) each in X,Y, and Z directions		
shock resistance	destruction: 500m/s <sup>2</sup> for 3 times each in X,Y, and Z directions		
degree of protection	IEC60529 IP50		
connection method	connector type (direct soldering possible)		
weight	approx. 3g		
material	case	Polybutylene terephthalate (PBT)	
	cover	Polycarbonate (PC)	
	emitter/receiver	Polycarbonate (PC)	

NPN TYPE  
CIRCUIT DIAGRAM

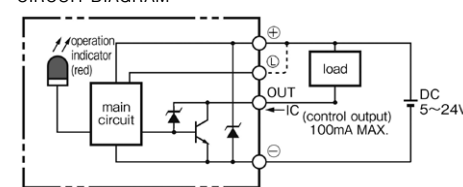

PNPTYPE  
CIRCUIT DIAGRAM

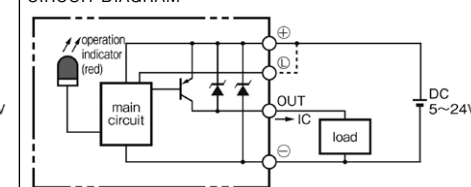

Please read the specifications and precautions of the manufacturer's catalog.

compact photomicro sensor (symbol: S)/ Panasonic Electric Works SUNX Co.,Ltd.

type	NPN TYPE	PM-L24
	PNP TYPE	PM-L24P
sensing range	5mm (fixed)	
minimum sensing object	0.8×1.8mm min. opaque	
hysteresis	0.05mm or less	
repeatability	0.03mm or less	
supply voltage	5 to 24 VDC ±10%, ripple(P-P) 10% or less	
current consumption	15mA or less	
output	NPN TYPE	NPN open-collector transistor maximum sink current: 50mA, applied voltage: 30VDC or less (between output and 0V) residual voltage: 0.7V or less (at 50mA sink current) 0.4V or less (at 16mA sink current)
	PNP TYPE	PNP open-collector transistor maximum source current: 50mA, applied voltage: 30VDC or less (between output and +V) residual voltage: 0.7V or less (at 50mA sink current) 0.4V or less (at 16mA sink current)
output operation	Incorporated with 2 outputs: Light-ON/Dark-ON	
response time	under light received condition: 20μs or less under light interrupted condition: 100μs or less (response frequency: 1kHz or more)	
operation indicator	vermillion LED (lights up under light received condition)	
ambient illuminance	fluorescent light: 1000lx at the light-receiving face	
ambient temperature	operating: -25 to 55°C (No dew condensation or icing allowed.) storage: -30 to 80°C	
ambient humidity	35 to 85% RH storage: 35 to 85%RH	
voltage withstandability	1000V AC for one min. between all supply terminals connected together and enclosure	
insulation resistance	50MΩ, or more, with 250V DC megger between all supply terminals connected together and enclosure	
vibration resistance	10 to 2,000Hz frequency, 1.5mm amplitude in X, Y, and Z directions for two hours each	
shock resistance	15,000m/s <sup>2</sup> acceleration (1,500 G approx.) in X, Y, and Z directions for three times each	
cable	0.09mm <sup>2</sup> 4-core cabtyre cable 1m long	
weight	approx. 10g	
material	case	Polybutylene telephthalate (PBT)
	cover	Polycarbonate

NPN TYPE  
CIRCUIT DIAGRAM

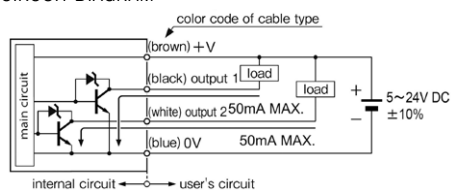

PNP TYPE  
CIRCUIT DIAGRAM

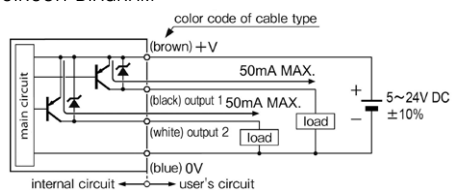

Please read the specifications and precautions of the manufacturer's catalog.

proximity sensor (symbol: K)/ Azbil CORPORATION

type	NPN TYPE	APM-D3B1,APM-D3B1F(different-frequency type)
	PNP TYPE	APM-D3E1,APM-D3E1F(different-frequency type)
rated sensing distance	2.5mm±15%	
standard target object	15×15mm, 1mm thick iron	
differential travel	15% max. of sensing distance	
rated supply voltage	12/24VDC	
operating voltage range	10.8 to 26.4 VDC (ripple voltage 10% max.)	
current consumption	10mA max.	
control output	NPN TYPE	NPN transistor open collector switching current: 30mA max. (resistive load) voltage drop: 1V max. (switching current 30mA) output dielectric strength: 26.4V
	PNP TYPE	PNP transistor open collector switching current: 30mA max. (resistive load) voltage drop: 1V max. (switching current 30mA) output dielectric strength: 26.4V
operation mode	normally closed (N.C.)	
operating frequency	120Hz	
indicator lamps	lights (red) when object approaches	
operating temperature range	-10 to 55°C storage: -25 to 70°C	
operating humidity range	35 to 85% RH	
ambient illumination(on receiver lens)	fluorescent light: 1000lxmax.	
dielectric strength	1000V AC (50/60Hz) for one min. between case and electrically live metals	
insulation resistance	50MΩ min. (by 500V DC megger )	
vibration resistance	10 to 55Hz, 1.5mm peak-to-peak amplitude, 2hrs in X, Y, and Z directions	
voltage withstandability	1000V AC(50/60Hz) for one min. between all supply terminals connected together and enclosure	
insulation resistance	50MΩ, or more( with 500V DC megger )	
shock resistance	500m/s <sup>2</sup> 3 times in Y,Y, and Z directions	
protection	IP67 (IEC 529)	
weight	approx. 10g	

NPN TYPE  
CIRCUIT DIAGRAM

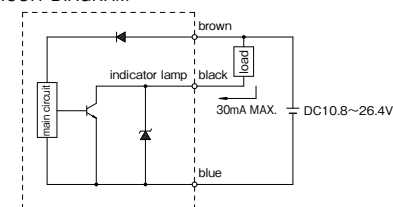

PNP TYPE  
CIRCUIT DIAGRAM

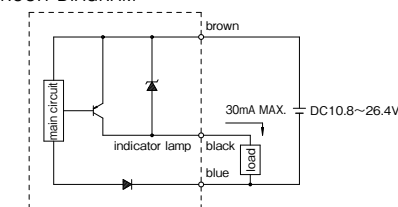

Please read the specifications and precautions of the manufacturer's catalog.

## POSITIONING PIN HOLE

For the BG type, positioning pin holes can be provided on the slide block and sub table by adding the option code "PS" or "PW" in the end of the part number.  
 The option code "PR" is used to provide the guide rail with positioning pin holes.  
 When positioning pin holes are necessary on both the slide block/sub table and guide rail, please add the option code "PSR" or "PWR"

Table H-14 Chart For Positioning

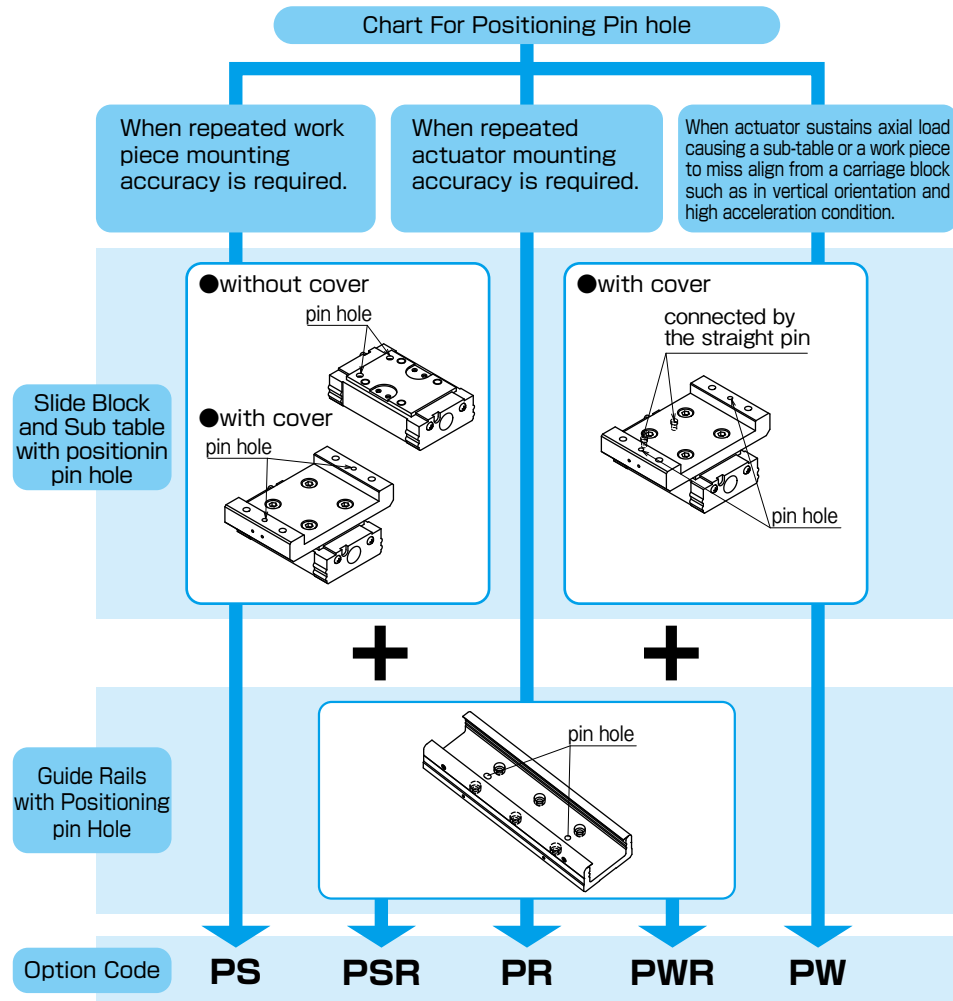

### Positioning Pin Hole for Slide Block and Sub Table

It is useful when exacting reassembly positioning is required. In case of two blocks used, both blocks are processed.  
 When the code "PS" is added, the drilling is processed only on the mounting surface (slide block or sub table). When the code "PW" is specified for a BG with a top cover (except for BG15), the slide block and sub table are connected by the straight pins at the location where the "PS" option specifies on the slide block.  
 Note that NB does not supply straight pins for the "PS" option.

### BG15A,B (long block)

(PS Option)  
 -With Top Cover-

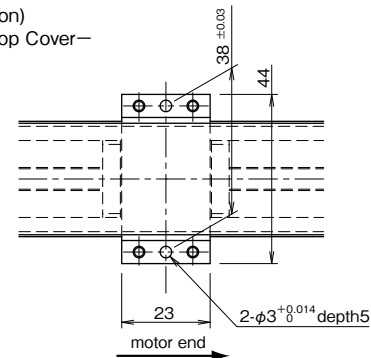

※Please contact NB for the without-top-cover option or the "PW" option.

### BG20A,B (long block)

(PS Option)  
 -Without Top Cover-

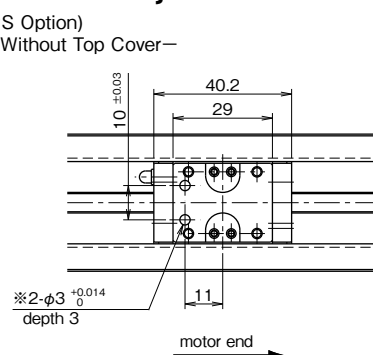

-With Top Cover-

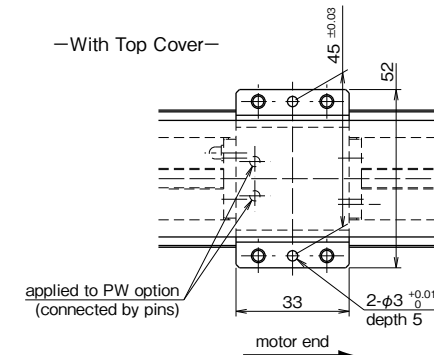

※For some cases, a shallow counterbore of φ4 will be machined at the hole area with "※" to remove a hardened layer.

### BG26A,B (long block)

(PS Option)  
 -Without Top Cover-

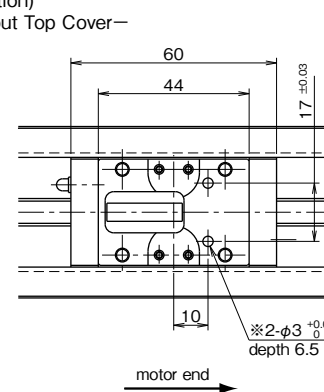

-With Top Cover-

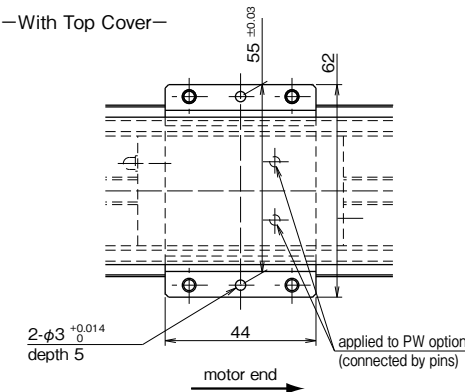

※For some cases, a shallow counterbore of φ4 will be machined at the hole area with "※" to remove a hardened layer.

### BG33A,B (long block)

(PS Option)

—Without Top Cover—

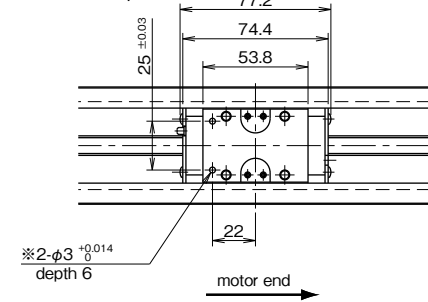

—With Top Cover—

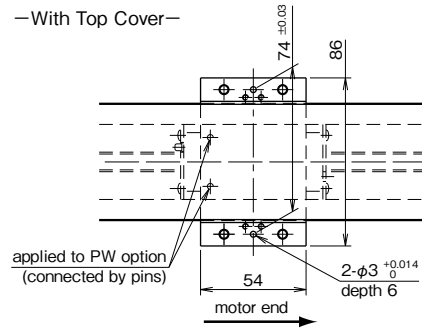

※For some cases, a shallow counterbore of φ4 will be machined at the hole area with "※" to remove a hardened layer.

### BG33C,D (short block)

(PS Option)

—Without Top Cover—

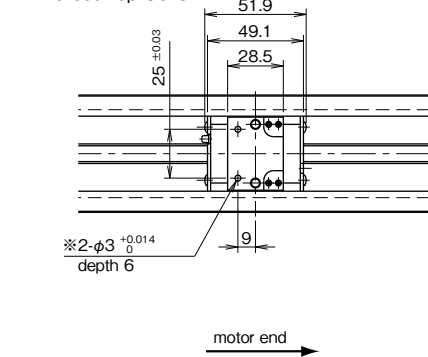

—With Top Cover—

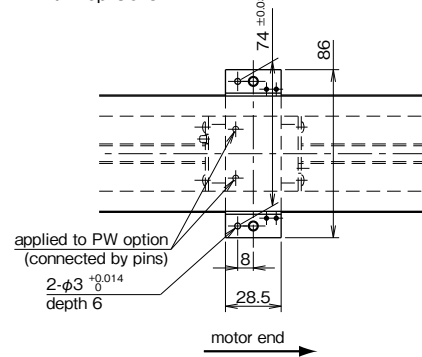

※For some cases, a shallow counterbore of φ4 will be machined at the hole area with "※" to remove a hardened layer.

### BG46A,B (long block)

(PS Option)

—Without Top Cover—

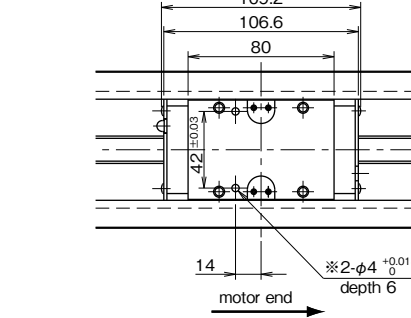

—With Top Cover—

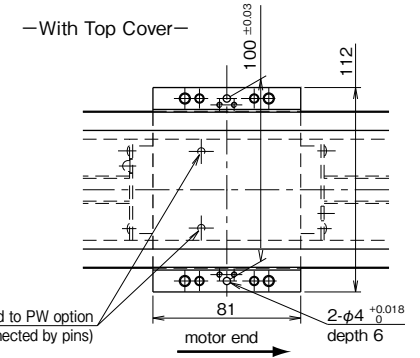

※For some cases, a shallow counterbore of φ5 will be machined at the hole area with "※" to remove a hardened layer.

### BG46C,D (short block)

(PS Option)

—Without Top Cover—

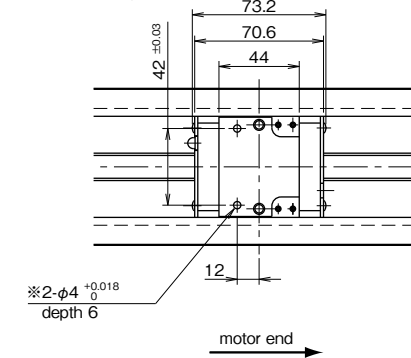

—With Top Cover—

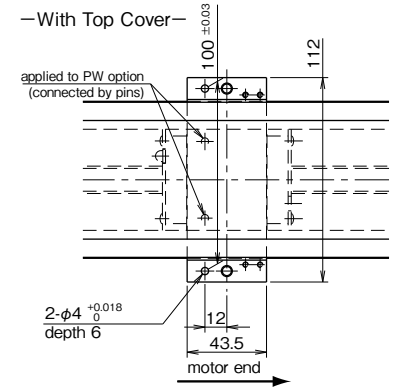

※For some cases, a shallow counterbore of φ5 will be machined at the hole area with "※" to remove a hardened layer.

### BG55A,B (long block)

(PS Option)

—Without Top Cover—

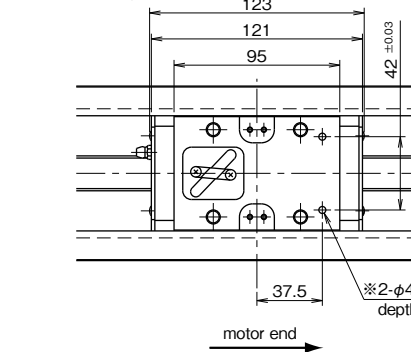

—With Top Cover—

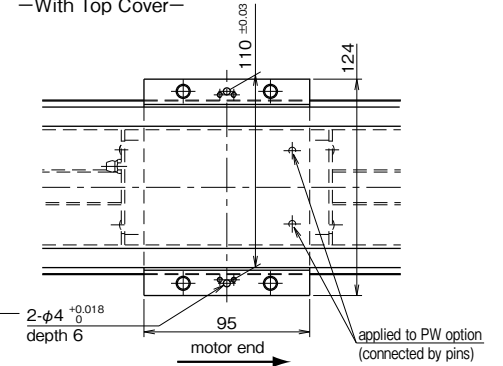

※For some cases, a shallow counterbore of φ5 will be machined at the hole area with "※" to remove a hardened layer.

POSITIONING PIN HOLE FOR GUIDE RAIL

It is useful to use positioning pin holes on the guide rail when exacting reassembly positioning is required. After the insertion of the straight pins in the BG guide rail base, the pins might interfere with the slide block. In the positioning process, please consider the BG base thickness. The length of the pin in the BG base shall be shorter than the BG base thickness. Please make sure that the pins shall not interfere with the slide block. Table H-15 shows the pin length in the BG base. Note that NB does not supply straight pins for the guide rail. (Parallel pin type A is recommended.)

Figure H-18 Positioning Pin Hole Location

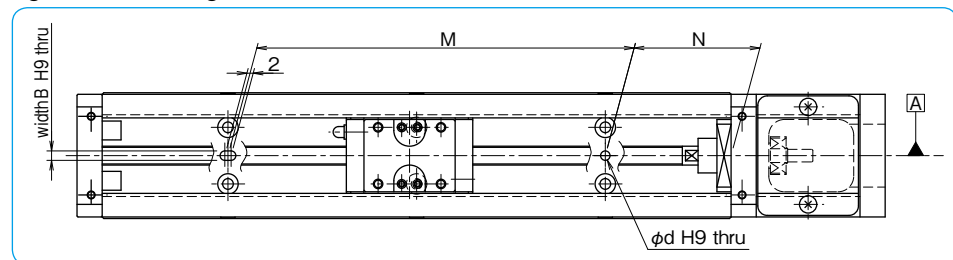

Table H-15 Positioning Pin Hole for Guide Rail

unit:mm					
part number	pin length (BG base thickness)	major dimensions			
		rail length	N	M	φd
BG15	3.5 or less	75	12.5	50	φ3 <sup>+0.025</sup> <sub>0</sub>
		100	25		
		125	12.5	100	
		150	25		
		175	12.5		
BG20	4.5 or less	200	25	150	
		100	20	60	
		150	15	120	
BG26	6 or less	200	40		
		150	35		
		200	20		
BG33	8 or less	250	45	160	
		300	30	240	
		150	25	100	
		200	50		200
		300			300
400	400				
500	500				
BG46	11 or less	600	70	400	
		340		200	
		440		300	
		540		400	
		640		500	
		740		600	
		840		700	
		940		800	
		1,040		900	
		1,140		1,000	
BG55	13 or less	1,240	1,100	1,050	
		980	40		900
		1,080	15		1,200
		1,180	65		
		1,280	40		
1,380	15	1,350			

LUBRICATION

- BG type contains a lithium soap based grease. (Multemp PS No.2, KYODO YUSHI) Apply similar type of grease for the lubrication as required depending on the operating conditions.
- Use the grease fitting to lubricate the slide block. For ball screw portion apply grease directly to the surface of screw shaft.
- ※ BG15 slide block has φ2mm oil holes instead of grease fitting.
- Unless otherwise instructed, a grease fitting is located as shown in Figure H-19.
- The grease can be changed to a high function type by adding a special grease option at the end of the part number. Please refer to Table H-16 for the grease type. Also refer to page Eng-39 for further details.

Figure H-19 Location of Grease Fitting

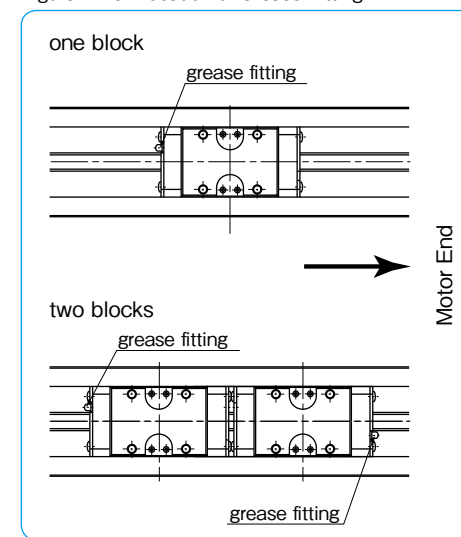

Table H-16 Applicable Grease

grease option	features	product name
none (standard)	—	Multemp PS No.2 (KYODO YUSHI)
GU	urea-type low dust generation grease; low sliding resistance	KGU Grease
GL	lithium-type low dust generation grease	KGL Grease
GF	urea-type anti-fretting grease	KGF Grease

OPERATING TEMPERATURE

- Resin parts are incorporated in the BG type. Please avoid using BG type above 80°C. Please use the product at 55°C or lower when sensor/bellows are optioned.

USE AND HANDLING PRECAUTIONS

- Please handle as a precision component and avoid excessive vibration or shock.
- Rough handling will affect the smooth motion and reduce the precision performance and life time.
- DO NOT DISASSEMBLE. The accuracy of BG type is preadjusted when assembled.
- Please allow for extra stroke length. If the guide block repeatedly collides with damper, it may cause damage.
- Please never touch the area at both stroke ends during operation. There is a danger for the fingers to be caught at the stroke end. Please pay enough attention to the guide rail area even when not in operation, there is a danger for the fingers to be injured by the dust cover.
- Depending upon the operating environment, dust and foreign particles may contaminate BG type and disrupt the ball circulation and precision performance.